

2025 CATALOGUE

EVENT
LIGHTING

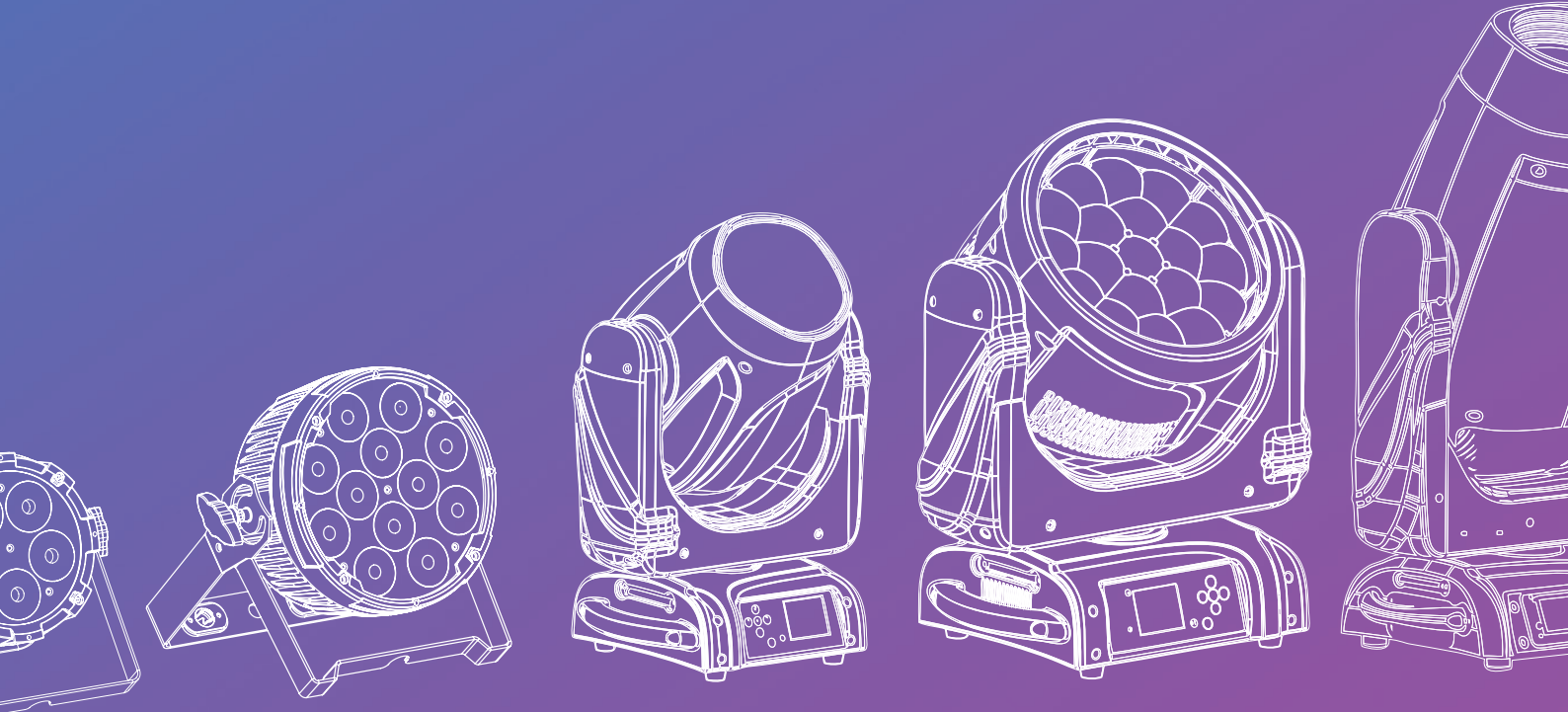
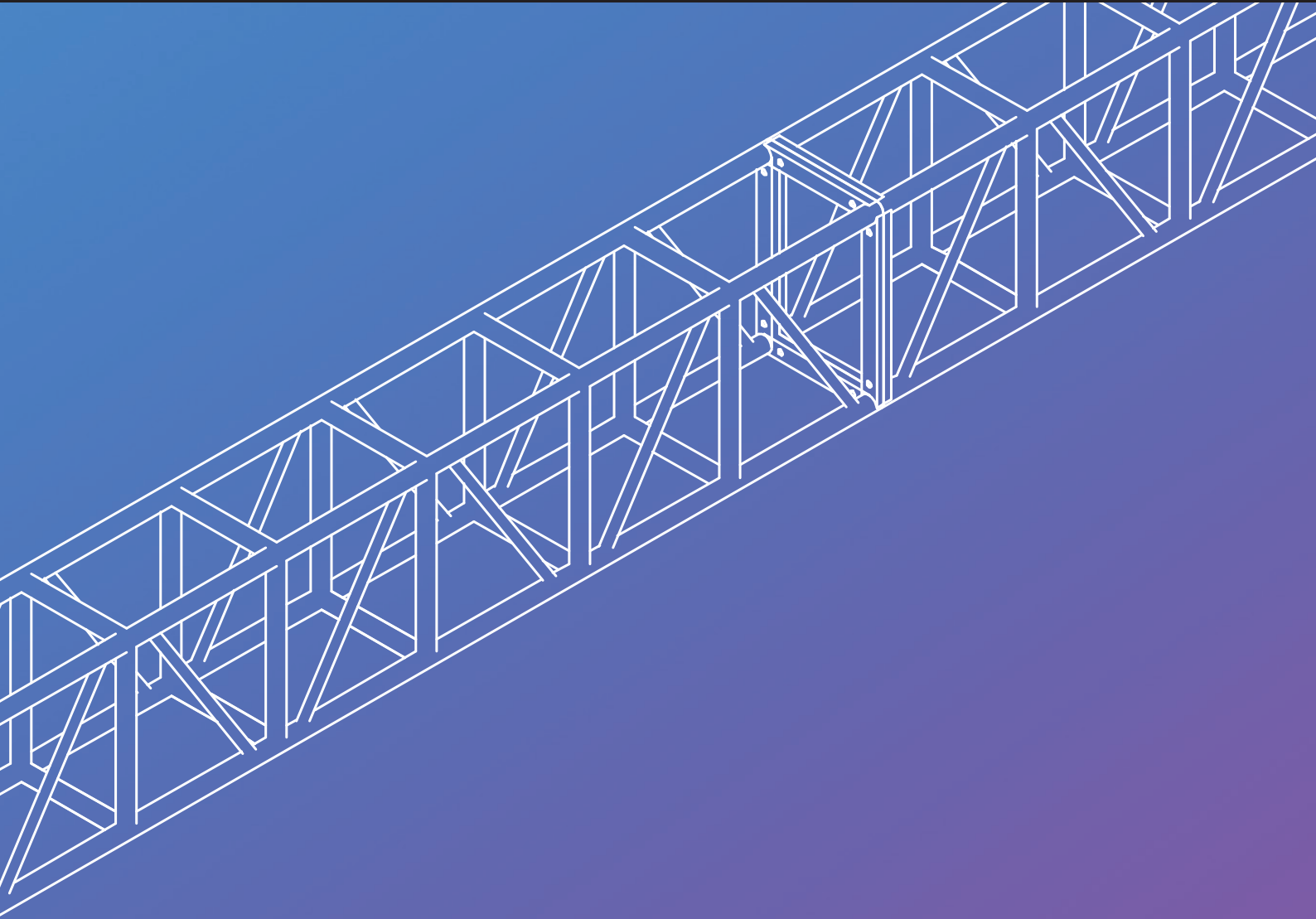

EVENT LIGHTING

Event Lighting was established in 2013 with a vision to supply professional entertainment lighting products to the Australian market without compromise.

Initially offering great value par fixtures that have earned a reputation of outstanding output and reliability, Event Lighting has expanded to include a diverse range of products in lighting, staging, trussing and rigging.

Event Lighting is proudly Australian owned and has partnered with numerous factories in China in order to further product development and maintain quality and consistency of the product ranges. Our relationships with the factories ensure we can offer the best quality products at reasonable price points while having our own staff in China ensures a high level of quality control and logistical arrangements.

Over the past 10 years, Event Lighting has achieved extraordinary growth, becoming a leading importer of professional entertainment equipment in Australia. During the past four years, Event Lighting has continued its growth, having to relocate to much larger office and warehouse premises in 2023.

In Australia, Event Lighting products are featured in many large production companies and all the well known retail businesses within the industry and beyond. Our growing international presence sees Event Lighting products reaching North America, South East Asia, China, Spain and New Zealand.

Combining extensive research, development and experience, Event Lighting is driven by the passion to create and deliver high quality products and lighting solutions which are designed to perform reliably and consistently.

CONTENT

MOVING HEADS	4-13
FRESNELS	14-15
PARCANS	16-21
PIXEL BARS / PANELS	22-27
RAIN COVERS.....	28
CASES.....	29
BOX TRUSS	30-35
TRIANGULAR TRUSS.....	36-39
FLAT TRUSS	40
BOLT TRUSS.....	41
FOLDING TRUSS	42
TUBE TRUSS.....	44
POWER TRUSS.....	45
TRUSS CORNERS	46-49
TRUSS BASES.....	50
TRUSS ACCESSORIES.....	51
TRUSS SYSTEMS.....	52-53
CUSTOM TRUSS.....	54
CROWD BARRIERS.....	55
STAGING.....	56-59
CLAMPS	60-65
AV REALM	66-67
ENGINEERING	68
AOKA STAGE EQUIPMENTS CO., LTD.....	69

OUTBACK350H / OUTBACK350H-WH

OUTDOOR MOVING HEAD HYBRID

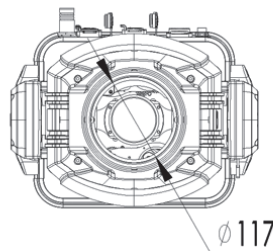
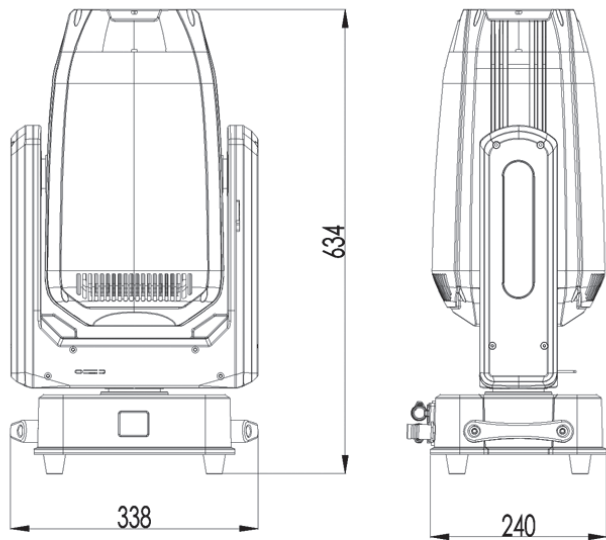

Photometrics

Light Source:	350W LED White
Beam Angle:	3° - 38°
Output:	69,703 lux @ 5m/ 8.2ft at 3°
Led lifespan:	>20,000 hours

Colour

5 Colour + Open (first wheel)
5 Colour + Open (second wheel)
Colour Mixing: CMY + CTO

Gobos

Rotating:	7 + Open (first wheel)
Rotating:	7 + Open (second wheel)
Gobo Shaking:	Yes
Gobo Indexing:	Yes

Effects

Dimming:	0-100%
Strobe:	1 - 25 Hz
Zoom:	Motorised 3° to 38°
Prism:	Prism(1): 4-Facet circular prism, indexing Prism(2): 4-Facet linear prism, indexing
Frost:	Yes

Movement

	16 bit resolution
	Auto repositioning
Pan:	540°
Tilt:	270°

Power

Power consumption:	500W Max.
Input Voltage:	100-240 V AC, 50/60 Hz
Connection:	True1 in/out

Control

Control Protocol:	DMX512, RDM
DMX Channels:	27 / 30
Interface:	3-pin & 5-pin XLR in/out
Display:	TFT control panel

Housing

Materials:	ABS & Steel, matte black or white finish
Protection:	High temperature automatic protection
IP rating:	IP65
Dimensions:	338 x 240 x 621mm / 13.3 x 9.4 x 24.4"
Net Weight:	20 kg / 44.1 lbs

Lux

	5m	10m	15m	20m
@ 3°	Ø0.27 69,703	Ø0.52 16,072	Ø0.8 7,167	Ø1.05 3,897
@ 38°	Ø3.55 2,538	Ø6.92 646	Ø10.4 286	Ø13.8 163

Colour wheel (1)



Colour wheel (2)



Rotating gobo wheel (1)



Rotating gobo wheel (2)

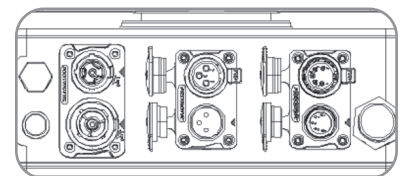

Road Case (Optional)

OUTBACK350HCASE1
Road case to suit 1 unit
of OUTBACK350H



OUTBACK180B / OUTBACK180B-WH

OUTDOOR MOVING HEAD BEAM

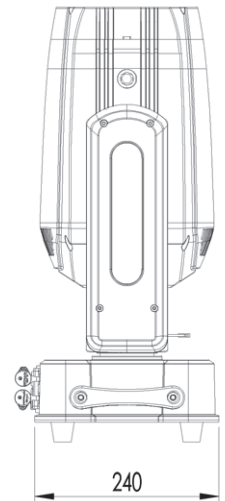
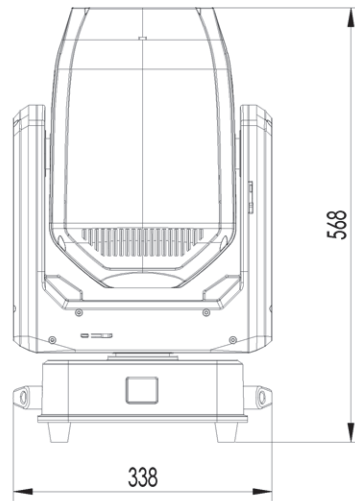
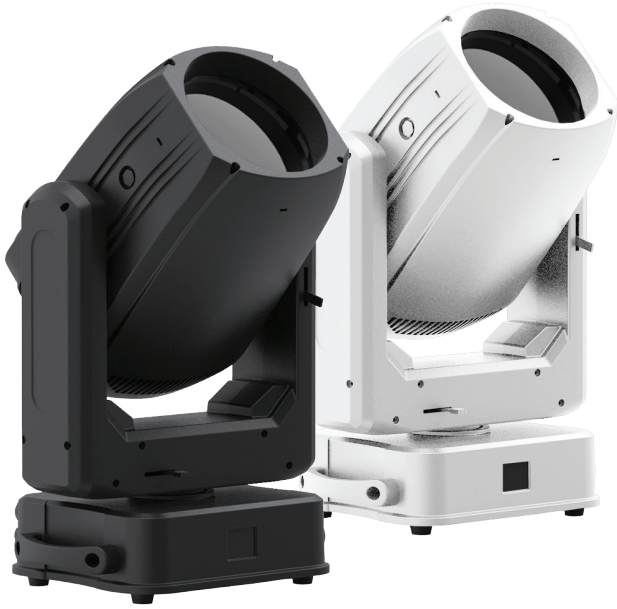

Photometrics

Light Source:	180W LED White
Beam Angle:	1.8°
Output:	191,301 lux @ 5m/ 8.2ft at 3°
Led lifespan:	>20,000 hours

Colour

5 Colour + Open (first wheel)
5 Colour + Open (second wheel)

Gobos

Fixed:	10 + Open
Rotating:	4
Gobo Shaking:	Yes
Gobo Indexing:	Yes

Effects

Dimming:	0~100%
Strobe:	1 - 25 Hz
Focus:	Motorised
Prism:	Prism(1): 24-Facet circular prism Prism(2): 5-Facet linear prism, indexing
Prism Overlap:	Yes
Frost:	Yes

Movement

16 bit resolution
Auto repositioning

Pan:	540°
Tilt:	270°

Power

Power consumption:	260W Max.
Input Voltage:	100~240 V AC, 50/60 Hz
Connection:	True1 in/out

Control

Control Protocol:	DMX512, RDM
DMX Channels:	20 / 23
Interface:	3-pin & 5-pin XLR in/out
Display:	TFT control panel

Housing

Materials:	ABS & Steel, matte black or white finish
Protection:	High temperature automatic protection
IP rating:	IP65
Dimensions:	338 x 240 x 555mm / 13.3 x 9.4 x 21.9"
Net Weight:	16.5 kg / 36.4 lbs

Lux

	5m	10m	15m	2.0m
@ 1.8°	Ø0.16 191,301	Ø0.32 48,470	Ø0.48 21,363	Ø0.63 11,278

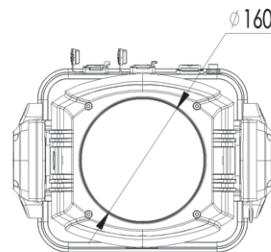

Colour wheel (1)



Colour wheel (2)



Fixed gobo wheel



Rotating gobo wheel

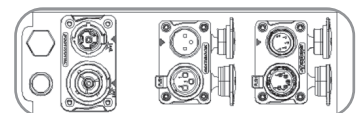

Road Case (Optional)

OUTBACK180BCASE2
Road case to suit 2 units
of OUTBACK180B



OUTBACK12X40W / OUTBACK12X40W-WH

OUTDOOR WASH MOVING HEAD

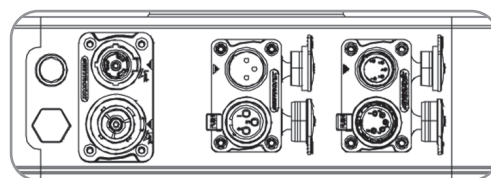
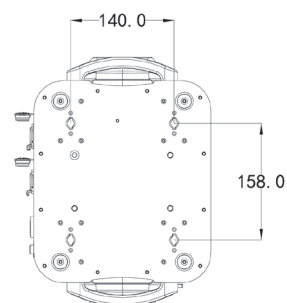
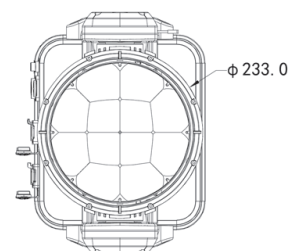
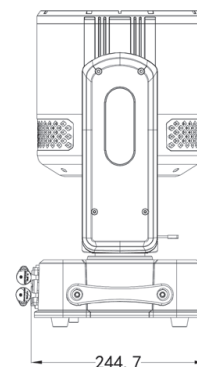
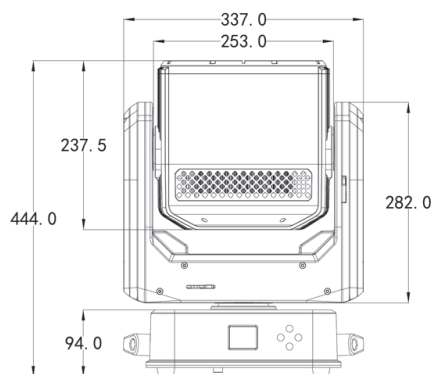

Photometrics

Light Source	12 x 40W RGBW 4-in-1 LEDs
Beam Angle	3° - 25°
Zoom Angle	3° - 45°
Output	34,250 lux@ 5m / 16.4ft at 3° 1,235 lux@ 5m / 16.4ft at 45°
CCT	2,500 - 10,000K
CRI	>70
LED Lifespan	>20,000 hours

Effects

Dimming	0~100%
Pixel Control	Yes
Strobe	1 - 25 Hz
Zoom	Motorised, 3° - 45°
Movement	16-bit auto reposition
Pan	540°
Tilt	270°

Power

Input Voltage	100~240 V AC, 50/60 Hz, 560 W
Connection	True1 in/out

Control

Operation Modes	DMX, auto, sound active, master/slave
Control Protocol	DMX512, RDM
DMX Channels	12 / 58
Control Interface	3-pin & 5-pin XLR in/out
Display	TFT control panel

Housing

Housing Materials	ABS and steel, matte black or white finish
Protection	High temperature automatic protection
IP rating	IP65
Dimensions:	337 x 240 x 474mm / 13.3 x 9.4 x 18.7"
Net Weight	11 kg / 24.3 lbs

Lux @ 3°	5.0m	10.0m	15.0m	20.0m
	Ø0.27	Ø0.52	Ø0.8	Ø1.05
Full	34,250	7,658	3,415	2,013

Lux @ 45°	5.0m	10.0m	15.0m	20.0m
	Ø4.1	Ø8.3	Ø12.4	Ø16.5
Full	1,235	346	186	123

Road Case (Optional)

OUTBACK12X40WCASE2
Road case to suit 2 units of
OUTBACK12X40W



HAVOCH600F / HAVOCH600F-WH

MOVING HEAD HYBRID WITH FRAMING

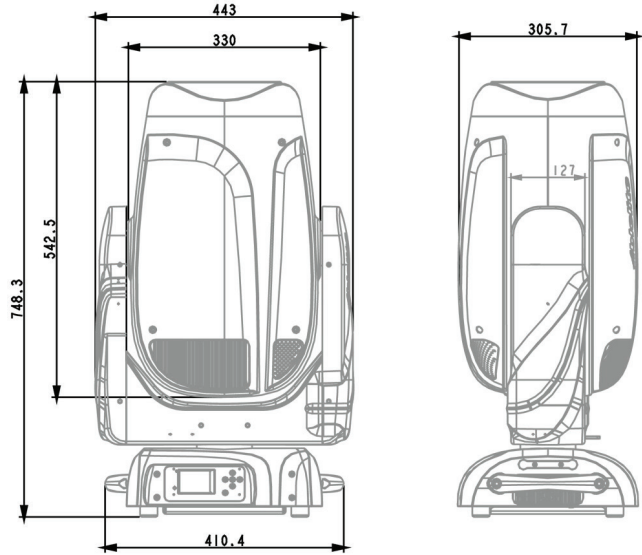

Photometrics

Light Source:	600w LED White
Beam Angle:	4°-50°
Output:	20,050 lumen, 85,000 lux @ 2.5m / 8.2ft at 5°
Led lifespan:	>20,000 hours

Colour

8 Colours + Open
Linear CMY+CTO

Gobos

Fixed:	8 + Open
Rotating:	7+ Open
Animation:	Yes

Effects

Dimming:	0~100%
Strobe:	Yes
Focus:	Motorised
Prism:	Rotating 4 facets
Frost:	Yes
Zoom:	Yes (4° to 50°)

Movement

	16 bit resolution
	Auto repositioning
Pan:	630° (4.4 sec) or 540°(3.9 sec)
Tilt:	233° (2.3 sec)

Power

Power consumption:	590W Max.
Input Voltage:	100~240 V AC, 50/60 Hz
Connection:	Neutrik® PowerCON in/out

Control

Control Protocol:	DMX512, RDM, Art-Net, optional CRMX
DMX Channels:	28/30/37/38
Interface:	5-pin XLR in/out, RJ45 in/out
RDM:	function to change DMX address
Display	2.4" colour LCD control panel
Software Upgrade	Yes, via DMX

Housing

Materials:	ABS & Steel, matte black or white finish
Dimensions:	443 x 748 x 305mm / 17.4 x 29.4 x 12"
Cooling:	Multi sensor thermostat controlled variable speed fan
IP rating:	IP20
Net Weight:	31 kg / 68.3 lbs
Rigging:	2x omega brackets with 1/4-turn quick locks

Lux

	2.5m	5.0m	7.5m	10.0m
@ 6°	Ø0.27	Ø0.55	Ø0.81	Ø1.08
	85,700	21,720	9,630	5,503
@ 48°	Ø2.23	Ø4.45	Ø6.68	Ø8.90
	4,377	1,535	715	530



Colour wheel



Fixed gobo wheel

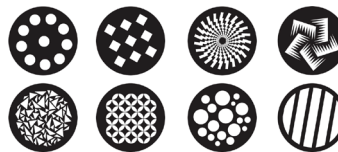

Rotating gobo wheel

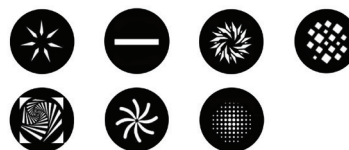

Road Case (Optional)

HAVOCH600FCASE1

Road case to suit 1 unit of HAVOCH600F (Horizontal loading)



HAVOCH330 / HAVOCH330-WH

MOVING HEAD HYBRID

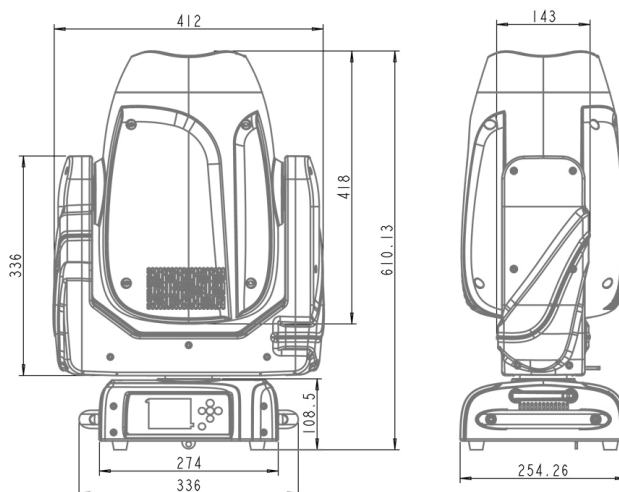

Photometrics

Light Source:	380w LED White
Beam Angle:	4°-48°
Output:	8,372 lumen, 89,500 lux @ 5m / 16.4ft at 4°
Led lifespan:	60,000 hours

Colour

9 Colours + CMY + Open
CMY

Gobos

Fixed:	11 + Open
Rotating:	8+ Open
Animation:	Yes

Effects

Dimming:	0~100%
Strobe:	Yes
Focus:	Motorised
Prism:	Rotating 3 facets
Frost:	Yes
Zoom:	Yes (4° to 48°)

Movement

	16 bit resolution
	Auto repositioning
Pan:	630° (4.0 sec) or 540°(3.58 sec)
Tilt:	265° (2.8 sec)

Power

Power consumption:	490W Max.
Input Voltage:	100~240 V AC, 50/60 Hz
Connection:	Neutrik® PowerCON in/out

Control

Control Protocol:	DMX512, RDM, optional Art-Net, optional CRMX
DMX Channels:	24
Interface:	3-pin/5-pin XLR in/out
RDM:	function to change DMX address
Display:	2.4" colour LCD control panel
Software Upgrade:	Yes via RDM

Housing

Materials:	ABS & Steel, matte black or white finish
Dimensions:	412 x 610 x 254mm / 16.2 x 24.0 x 10.0"
Cooling:	Multi sensor thermostat controlled variable speed fan
IP rating:	IP20
Net Weight:	21.5 kg / 47.4 lbs
Rigging:	2x omega brackets with 1/4-turn quick locks

Lux

	5.0m	10.0m
@ 4°	Ø0.34	Ø0.87
	89,500	21,900
@ 48°	Ø4.46	Ø8.9
	1,420	378



Colour wheel



Fixed gobo wheel

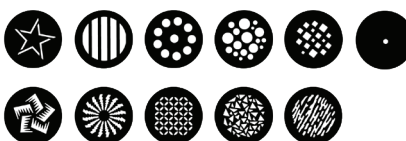

Rotating gobo wheel



Road Case (Optional)

HAVOCH330CASE2

Road case to suit 2 units
of HAVOCH330



HAVOCH200 / HAVOCH200-WH

MOVING HEAD HYBRID

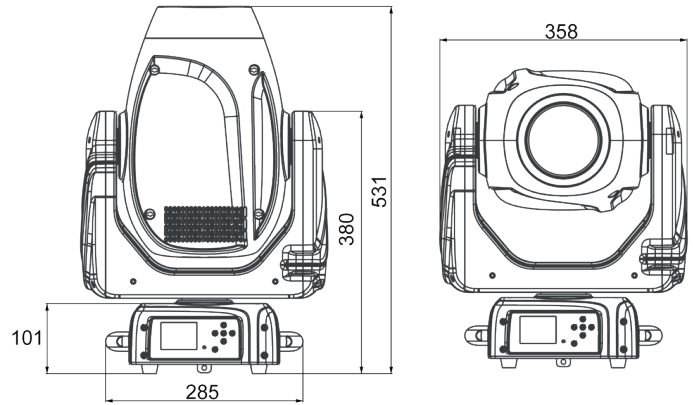

Photometrics

Light Source:	200w LED White
Beam Angle:	4°-30.8°
Output:	6,940 lumen, 65,166 lux @ 5m / 16.4 ft at 4°
Led lifespan:	60,000 hours

Colour

11 Colours + Open
Indexable and bideractional rainbow effect
Colour bounce

Gobos

Fixed:	17 + Open
Rotating:	8+ Open
Animation:	Yes

Effects

Dimming:	0~100%
Strobe:	Yes
Focus:	Motorised
Prism:	5 facets
Frost:	Yes
Zoom:	Yes (4° to 30.8°)

Power

Power consumption:	292W Max.
Input Voltage:	100~240 V AC, 50/60 Hz
Connection:	True 1 in/out

Control

Control Protocol:	DMX512, RDM, optional Art-Net, optional CRMX
DMX Channels:	20
Interface:	3-pin / 5-pin XLR in/out, RJ45 in/out
RDM:	function to change DMX address
Display	2.4" colour LCD control panel
Software Upgrade	Yes, via DMX or USB

Housing

Materials:	ABS & Steel, matte black or white finish
Dimensions:	531 x 258 x 345mm / 20.9 x 10.2 x 13.6"
Cooling:	Multi sensor thermostat controlled variable speed fan
IP rating:	IP20
Net Weight:	15 kg / 33.1 lbs

Colour wheel



Fixed gobo wheel

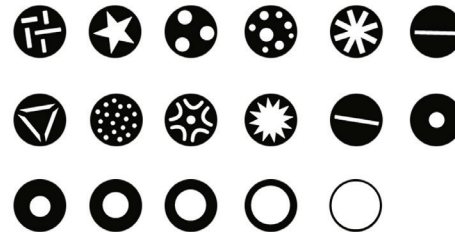

Rotating gobo wheel



Road Case (Optional)

HAVOCH200CASE2
Road case to suit 2
units of HAVOCH200



Lux

	2.0m	5.0m	7.5m	10.0m
@ 4°	Ø0.27	Ø0.70	Ø1.05	Ø1.40
	380,263	60,842	27,041	15,211
@ 30.8°	Ø2.38	Ø5.96	Ø8.94	Ø11.92
	7,885	1,262	561	315

HAVOCS150 / HAVOCS150-WH

MOVING HEAD SPOT

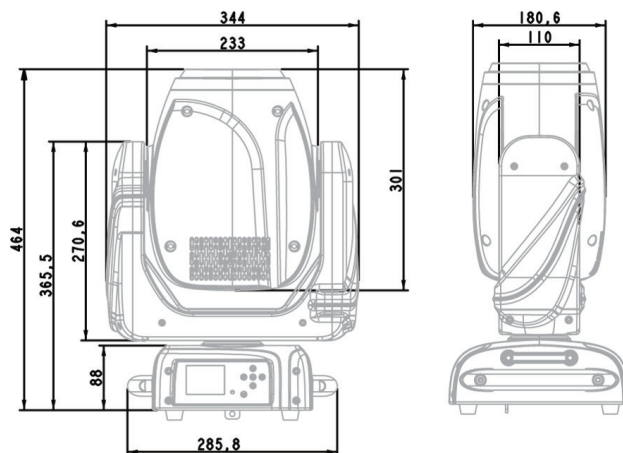

Photometrics

Light Source:	150W LED White
Beam Angle:	10.2°-48.4°
Output:	9,270 lux @ 5m / 16.4ft at 10.2°
Led lifespan:	50,000 hours

Colour

8 Colours + Open

Movement

Pan:	540° (2.4 sec)
Tilt:	263° (1.3 sec)
Resolution:	16-bit
Repositioning:	Auto

Gobos

Fixed:	10 + Open
Rotating:	7+ Open

Effects

Dimming:	0~100%
Strobe:	Yes
Prism:	3 facets
Frost:	Yes
Zoom:	Yes (10.2°-48.4°)

Power

Power consumption:	206W Max.
Input Voltage:	100~240 V AC, 50/60 Hz
Connection:	True1 in/out

Control

Control Protocol:	DMX512, RDM, Optional Wireless
DMX Channels:	17 / 21
Interface:	3-pin / 5-pin XLR in/out
RDM:	function to change DMX address
Display:	2.4" colour LCD control panel
Software Upgrade:	Yes, via DMX or USB

Housing

Materials:	ABS & Steel, matte black or white finish
Dimensions:	464 x 334 x 181mm / 18.3 x 13.1 x 7.1"
Cooling:	Multi sensor thermostat controlled variable speed fan
IP rating:	IP20
Net Weight:	14 kg / 30.9 lbs

Colour wheel

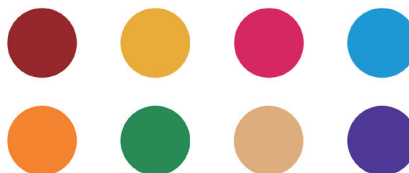

Fixed gobo wheel

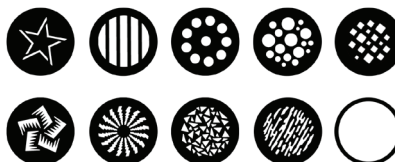

Rotating gobo wheel



Lux

	3.0m	5.0m	7.0m
@ 10.2°	Ø0.54	Ø0.92	Ø1.3
	27,100	9,270	4,860
@ 48.4°	Ø2.58	Ø4.30	/
	1,540	574	/

Road Case (Optional)

HAVOCH150CASE2
Road case to suit 2
units of HAVOCH200



HAVOCB120 / HAVOCB120-WH

MOVING HEAD BEAM

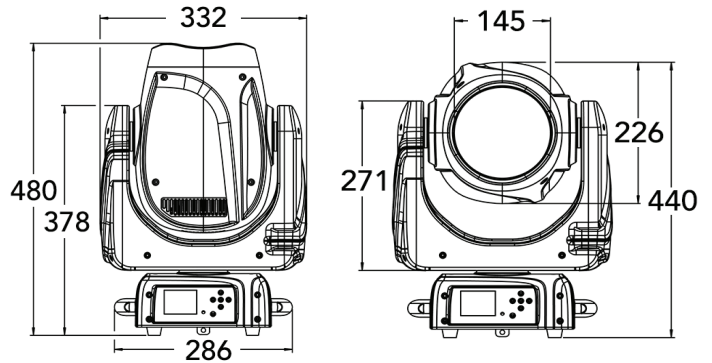

Photometrics	
Light Source	120 W White LED
Beam Angle	1°
Output	12,170 lumen, 150,000 lux @ 5 m / 16.4 ft
LED Lifespan	60,000 hours
Colour	
Colour Wheel	14 colours + open
Gobo	17 gobos + open
Effects	
Focus	Motorised
Prism	6-linear and 8-facets prisms
Frost	Yes
Movement	
Pan	8/16-bit auto reposition 630° (4.3s)/540° (3.9s)
Tilt	233° (2.2s)
Power	
Input Voltage	100~240 V AC, 50/60 Hz, 172W
Connection	True1 in/out
Fuse	T 3.15 A, 250 V
Control	
Operation Modes	DMX, auto, sound active, master/slave
Control Protocol	DMX512, RDM, optional Art-Net, optional CRMX
DMX Channels	14 / 16
Control Interface	3-pin XLR in/out, 5-pin XLR in/out
Display	2.4" colour LCD control panel with battery power
Housing	
Housing Materials	ABS and steel, matte black or white finish
Finishing	Matte Black
Cooling	Multi-sensor thermostat controlled variable speed fan
IP Rating	IP20
Dimensions:	480 x 332 x 286mm / 18.9 x 13.1 x 11.3"
Net Weight	12.75 kg / 28.1 lbs
Rigging	2x omega brackets with ¼ turn quick locks
Accessories	
Optional	Road Case: HAVOCB120C



Colour wheel



Fixed gobo wheel

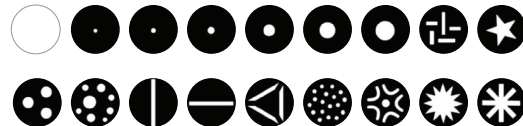

Road Case (Optional)

HAVOCB120CASE4
Road case to suit 4
units of HAVOCB120



Lux	5.0m	7.0m	10.0m
@ 1°	Ø0.15	Ø0.22	Ø0.3
Full	150,000	82,000	40,900

HAVOCW19X40 / HAVOCW19X40-WH

WASH MOVING HEAD

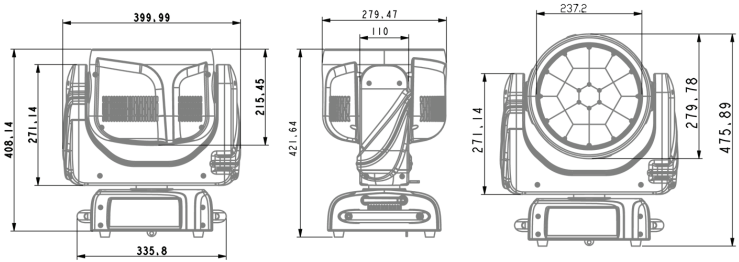

Photometrics

Light Source	19x OSRAM 40W RGBW 4-in-1 LEDs
Beam Angle	5°~45°
Output	107,431 lux@ 3m / 9.8ft at 5° 2,355 lux@ 3m / 9.8ft @ 45°
Control:	Remote on/off via DMX
LED Lifespan	60,000 hours

Effects

Dimming	0~100%
Pixel Control	Yes
Strobe	Yes
Zoom	Motorised, 5°~45°

Movement

Pan	630° (2.2s) / 540° (2.0s)
Tilt	265° (0.85s)

Power

Input Voltage	100~240 V AC, 50/60 Hz, 231 W
Connection	Neutrik ® powerCON in/out 5 pin DMX in/out, 3 pin DMX in/out

Control

Operation Modes	DMX, auto, sound active, master/slave
Control Protocol	DMX512, RDM, optional Art-Net, optional CRMX
DMX Channels	19/98/18/20
Control Interface	3-pin & 5-pin XLR in/out
Display	2.4" colour LCD control panel, with battery
Software	Upgradable via DMX

Housing

Housing Materials	ABS and steel, matte black or white finish
Cooling	Multi-sensor thermostat controlled variable speed fan
Dimensions:	475 x 400 x 336mm / 18.7 x 15.7 x 13.2"
Net Weight	20.9 kg / 46.1 lbs
Rigging	Omega bracket & safety chain

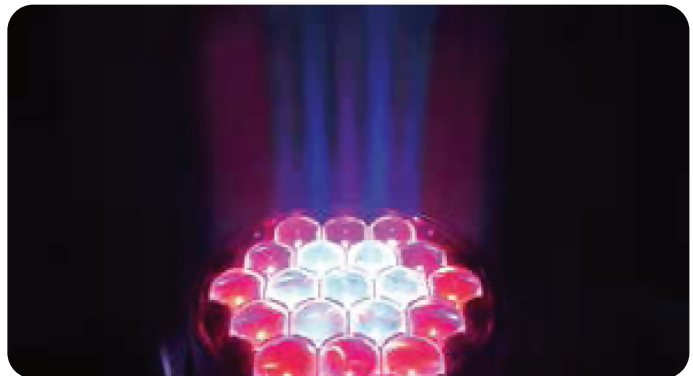

Lux @ 5°	3.0m	5.0m	7.0m
	Ø0.19	Ø0.31	Ø0.44
R	5,540	2,000	880
G	10,300	3,740	1,690
B	2,130	781	352
W	16,000	5,870	2840
Full	110,621	39,823	20,318



Lux @ 45°	3.0m	5.0m	7.0m
	Ø2.0	Ø3.33	Ø4.67
R	536	191	96.6
G	966	354	164
B	199	72.3	32.7
W	1,440	529	241
Full	2355	847.9	432.6

Road Case (Optional)

HAVOCW19X40CASE2

Road case to suit
2 units of HAVOC-
W19X40



HAVOCW7X40 / HAVOCW7X40-WH

WASH MOVING HEAD

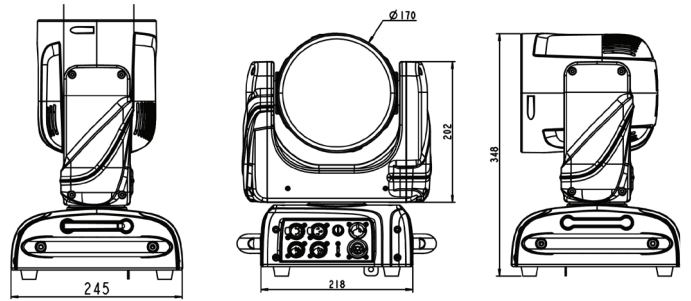

Photometrics	
Light Source	7x OSRAM 40W RGBW 4in1 LEDs
Beam Angle	6°~50°
Output	(6°) 16,900 lux at 3m / 9.8ft (50°) 986 lux at 3m / 9.8ft
Control:	Remote on/off via DMX
LED Lifespan	60,000 hours
Effects	
Dimming	0~100%
Pixel Control	Yes
Strobe	0.5~26 Hz
Zoom	Motorised, 6°~50°
Movement	
	16-bit auto reposition
Pan	630° (3.04s)/540° (2.61s)
Tilt	265° (1.03s)
Power	
Input Voltage	100~240 V AC, 50/60 Hz, 231 W
Connection	Neutrik @ powerCON in/out 5 pin DMX in/out, 3 pin DMX in/out
Control	
Operation Modes	DMX, auto, sound active, master/slave
Control Protocol	DMX512, RDM, optional Art-Net, optional CRMX
DMX Channels	26/38/8/28
Control Interface	3-pin & 5-pin XLR
Display	2.4" colour LCD control panel, with battery
Software	Upgradable via DMX
Housing	
Housing Materials	ABS and steel, matte black or white finish
Cooling	Multi-sensor thermostat controlled variable speed fan
Dimensions:	286 x 245 x 372mm / 11.3 x 9.6 x 14.6"
Net Weight	7.4 kg / 16.3 lbs
Rigging	Omega bracket & safety chain
Accessories	
Optional	Road case: HAVOCW7X40C

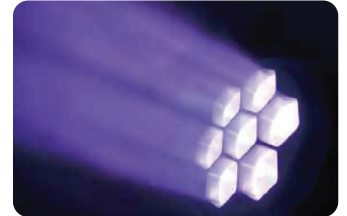

Lux @ 6°			
	3.0m	5.0m	
	Ø0.5	Ø0.73	
R	7,040	2,440	
G	12,600	4,780	
B	3,820	1,030	
W	2,850	7,260	
Full	17,900	13,500	



Lux @ 50°			
	3.0m	5.0m	
	Ø3.15	-	
R	175	99	
G	359	125	
B	80	35	
W	489	166	
Full	968	375	

Road Case (Optional)

HAVOCW7X40CASE4
Road case to suit 4 units of HAVOCW7X40



F96VW / F96VW-WH

VARIABLE WHITE FRESNEL

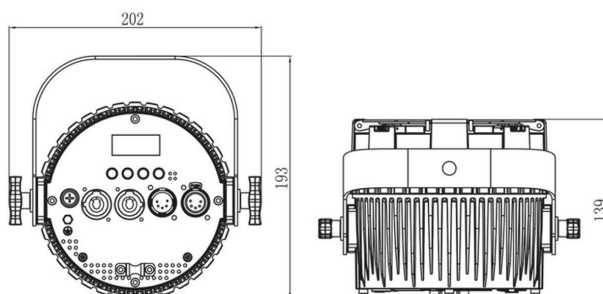

Photometrics

Light Source	48W Cool White 5,700K 48W Warm White 2,700K COB LED
Beam Angle	20°~50°
Field Angle:	50°~67°
Output	1,230 lux @ 3m / 9.8ft @ 20°, 395 lux @ 3m / 9.8ft @ 50°
Lens:	80mm Fresnel
PWM:	1,200Hz
LED Lifespan	50,000 hours

Effects

Dimming	0~100%, 16-bit
Strobe:	1~25Hz
Zoom:	Manual, 20°~50°

Power

Input Voltage	100~240 V AC, 50/60 Hz, 75 W
Connection	True1 in/out

Control

Operation Modes	Manual, Master / Slave & DMX, WDMX (optional)
Control Protocol	DMX512
DMX Channels	1 / 2 / 7
Control Interface	5-pin XLR in/out
Display	LCD control panel with four buttons

Housing

Housing Materials	Die- cast Aluminum Housing
Housing Finishing:	Matte Black or White
Cooling	Fanless Cooling with Temperature Protection
Dimensions:	202 x 139 x 193mm / 8.0 x 5.5 x 7.6"
Net Weight	2.3 kg / 6.6 lbs
Barn Door	Included
Gel Clip	Included



Lux @ 20°		F96VW				
	1.0m	2.0m	3.0m	4.0m	5.0m	
	Ø0.35	Ø0.71	Ø1.06	Ø1.41	Ø1.76	
2700K	5,100	1,200	546	298	198	
5700K	6,850	1,680	745	422	445	
FULL	11,600	2,780	1,230	685	445	

Lux @ 50°		F96VW				
	Ø0.93	Ø1.87	Ø2.8	Ø3.73	Ø4.66	
	1,550	393	172	106	75	
2700K	2,150	530	245	148	104	
5700K	3,600	895	395	245	175	

Road Case (Optional)

F96VWCASE6
Road Case to suit 6 units
F96VW Fresnels



OPERAC100VWF / OPERAC100VWF-WH

COMPACT FRESNEL ENGINE WITH 100W COB VARIABLE WHITE LED

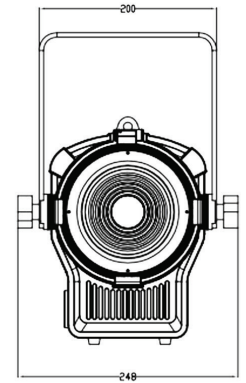
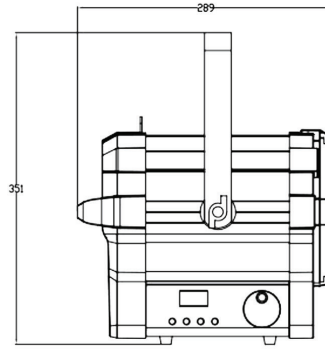
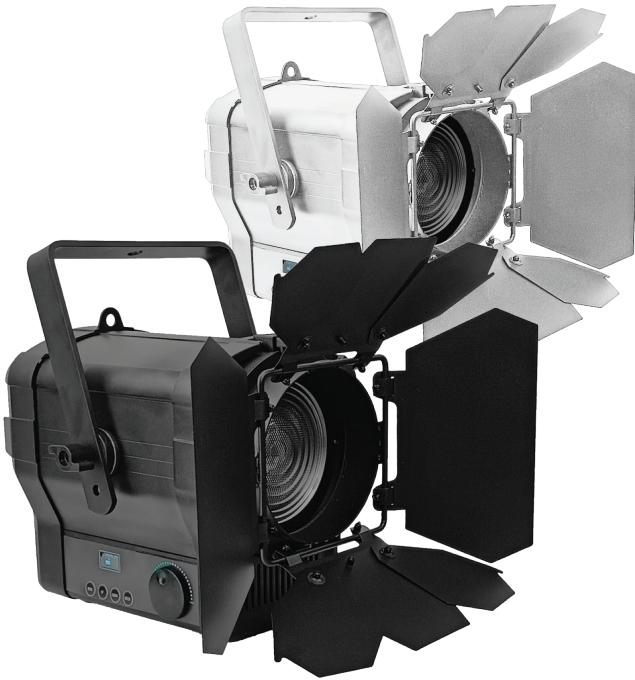

Photometrics	
Light Source:	100W COB VW LED
CRI:	95
Beam Angle:	14°~55°
Colour temperature:	3200K-5600K adjustable
Output:	100W
PWM:	1,000 Hz - 16,000 Hz optional
LED Lifespan:	50,000 hours
Effects	
Dimming:	0~100%, 16-bit, 3 dimmer curves optional, dimmer speed optional
Zoom:	Manual, 14°~55°
Optical system:	Glass lens set+ 120 mm Fresnel lens
Power	
Power Supply:	100~240 V AC, 50/60 Hz, 100 W
Power Connection:	True1 in / out
Control	
Operational Modes:	DMX, RDM, Manual
Display:	4-button TFT-LCD control panel
Control Protocol:	DMX512
Control Interface:	5 pin XLR - in / out
DMX Channels:	1CH / 2CH / 6CH / 9CH optional
Housing	
Housing Materials:	Die-cast aluminum, matte black finish
Tilt angle:	±90°
Cooling:	Silent fan, intelligent automatic temperature regulation system
IP rate:	IP23
Dimensions:	289 x 351x 248mm / 11.4 x 9.9 x 9.8"
Net Weight:	6.7 kg / 14.8 lbs
Accessories	
	Rotatable Barn Doors (Included)
	Gel Frame (Included)



Lux @ 14°			
	2.5m	5.0m	7.5m
3,200K	7,600	1,900	845
5,600K	10,663	2,666	1,185

Lux @ 55°			
	2.5m	5.0m	7.5m
3,200K	2,766	692	307
5,600K	4,000	1,000	444

Included Accessories

Rotatable Barn Doors

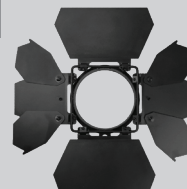

Gel Frame



PAR12H/ PAR12Q / PAR12VW [-WH]

12 X LED INDOOR RGBWAU / RGBW / CW-VW-A PAR

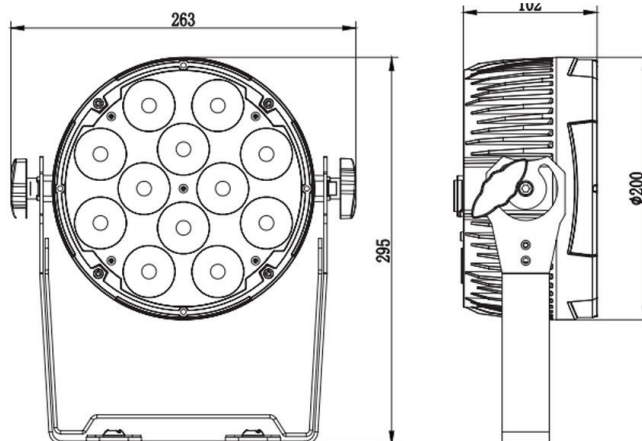

Photometrics	PAR12H	PAR12Q	PAR12VW
Light Source:	12x 12W RGBWA+UV LEDs	12x 8W RGBW LEDs	12x 6W CW/WW/A LEDs
Beam Angle:	30° (optional: 55°)		
Output:	3,150 lux @ 2m / 6.6ft full on	4,680 lux @ 2m / 6.6ft full on	3,270 lux @ 2m / 6.6ft full on
PWM:	2,940 Hz		
Led lifespan:	50,000 hours		
Effects			
Dimming:	5 x 16-bit Dimming Curves		
Strobe:	1~30 Hz		
Power			
Power consumption:	120W Max	98W Max	60W Max
Input Voltage:	100~240 V AC, 50/60 Hz		
Connection:	True1 in/out		
Control			
Control Protocol:	DMX512, WDMX (optional)		
DMX Channels:	1 / 2 / 3 / 4W / 4A / 6 / 8 / 12 / 14	1 / 2 / 3 / 4 / 6 / 10	1 / 2 / 3 / 10
Interface:	5-pin XLR in/out		
Operational Modes:	DMX, WDMX (optional), auto run, sound active, master/slave, manual colour control, static colour control		
Display	4-button LCD control panel		
Housing			
Materials:	Die-cast aluminium, matte black or white finish		
Dimensions:	263 x 293 x 98mm / 10.4 x 11.5 x 3.9"		
Cooling:	Fanless Cooling		
IP rating:	IP20		
Net Weight:	3.2 kg / 7.1 lbs		
Rigging:	1x omega brackets with 1/4-turn quick locks		

Optional Accessories

PAR12BDKIT [-WH]

Rotatable Barn Doors with base, gel frame, frost and safety loop



PAR12GELFR

Gel frame for PAR12H/Q/VW



PAR12FROST

Frost filter for PAR12H/Q/VW



Lux @ 30°	PAR12H				
	1.0m	2.0m	3.0m	4.0m	5.0m
R	2,520	638	298	171	105
G	3,175	825	376	209	128
B	2,308	603	268	153	86
W	4,524	1,320	679	324	199
A	1,751	462	212	119	76
U	801	217	97	55	33
Full	12,800	3,150	1,350	760	505

Lux @ 30°	PAR12Q				
	1.0m	2.0m	3.0m	4.0m	5.0m
R	4,180	1,040	469	265	170
G	6,570	1,620	760	428	278
B	2,050	515	231	133	84
W	7,790	1,980	883	500	329
Full	18,300	4,680	2,090	1,170	771

Lux @ 30°	PAR12VW				
	1.0m	2.0m	3.0m	4.0m	5.0m
CW	5,570	1,425	637	370	240
WW	4,750	1,217	545	315	202
A	3,180	847	365	217	142
Full	12,610	3,270	1,473	845	542

Road Case (Optional)

PAR12CASEWC

Road Case to suit 10 units of PAR12 Par Cans



Road Case (Optional)

PAR12BDCASEWC

Road Case to suit 8 units of PAR12 Par Cans with barn doors



PAR5H/ PAR5Q / PAR5VW - [WH]

5 X LED INDOOR RGBWAU / RGBW / CW-VW-A PAR

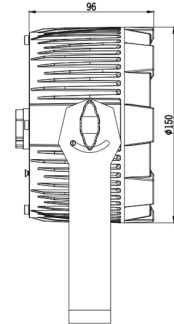
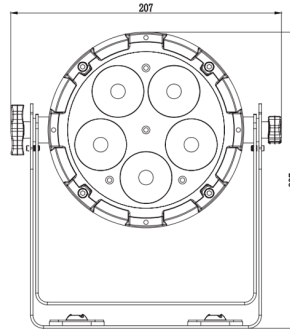

Photometrics	PAR5H	PAR5Q	PAR5VW
Light Source:	5x 12W RGBWA+UV LEDs	5x 8W RGBW LEDs	5x 6W CW/WW/A LEDs
Beam Angle:	30° (optional: 55°)		
Output:	1,420 lux @ 2m / 6.6ft full on	2,000 lux @ 2m / 6.6ft full on	1,610 lux @ 2m / 6.6ft full on
PWM:	2,940 Hz		
Led lifespan:	50,000 hours		
Effects			
Dimming:	5 x 16-bit Dimming Curves		
Strobe:	1~30 Hz		
Power			
Power consumption:	50W Max	40W Max	35W Max
Input Voltage:	100~240 V AC, 50/60 Hz		
Connection:	True1 in/out		
Control			
Control Protocol:	DMX512, WDMX (optional)		
DMX Channels:	1 / 2 / 3 / 4W / 4A / 6 / 8 / 12 / 14	1 / 2 / 3 / 4 / 6 / 10	1 / 2 / 3 / 10
Interface:	5-pin XLR in/out		
Operational Modes:	DMX, WDMX (optional), auto run, sound active, master/slave, manual colour control, static colour control		
Display	4-button LCD control panel		
Housing			
Materials:	Die-cast aluminium, matte black or white finish		
Dimensions:	207 x 227 x 120 mm / 8.1 x 8.9 x 4.7"		
Cooling:	Fanless Cooling		
IP rating:	IP20		
Net Weight:	1.9 kg / 4.2 lbs		
Rigging:	1x omega brackets with 1/4-turn quick locks		

Optional Accessories

PAR5BDKIT -[WH]

Rotatable Barn Doors with base, gel frame, frost and safety loop

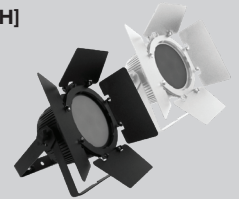

PAR5GELFR

Gel frame for PAR5H/Q/VW



PAR5FROST

Frost filter for PAR5H/Q/VW



Lux @ 30°	PAR5H				
	1.0m	2.0m	3.0m	4.0m	5.0m
R	980	265	105	60	41
G	1,350	350	165	90	62
B	925	250	112	65	45
W	1,680	560	250	145	98
A	850	220	90	50	38
U	260	68	30	18	12
Full	5,800	1,420	635	365	235

Lux @ 30°	PAR5Q				
	1.0m	2.0m	3.0m	4.0m	5.0m
R	1,800	438	196	113	72
G	2,900	732	325	190	120
B	895	214	93	55	34
W	3,410	854	378	220	140
Full	8,000	2,000	903	505	322

Lux @ 30°	PAR5VW				
	1.0m	2.0m	3.0m	4.0m	5.0m
CW	2,750	695	308	176	112
WW	2,380	604	268	153	98
A	1,640	411	182	102	65
Full	6,410	1,610	717	405	260

Road Case (Optional)

PARSCASEWC

Road Case to suit 12 units of PAR5 Par Cans



Road Case (Optional)

PAR5BDCASEWC

Road Case to suit 8 units of PAR5 Par Cans with barn doors



PAR12X20H-IP / PAR12X20H-IP-WH

OUTDOOR PRO PAR

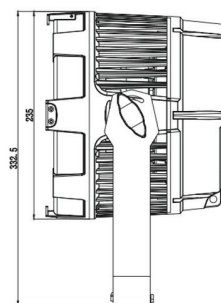
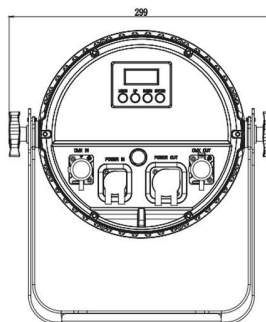

Photometrics	
Light Source:	12x 20W RGBWA+UV 6 in 1 LED
Beam Angle:	22°
Output:	12,700 lux @ 2m / 6.6ft full on
PWM:	1,240 Hz
Led lifespan:	50,000 hours
Effects	
Dimming:	5 x 16-bit Dimming Curves
Strobe:	1~30 Hz
Power	
Power consumption:	250W Max
Input Voltage:	100V~240 V AC, 50/60Hz
Connection:	True1 in/out
Control	
Control Protocol:	DMX512
DMX Channels:	1 / 2 / 3 / 4W / 4A / 6 / 8 / 12 / 14
Interface:	5-pin XLR in / out
Operational Modes:	DMX, WDMX, auto run, sound active, master/slave, manual colour control, static colour control
Display:	4-button LCD control panel
Housing	
Materials:	Die-cast aluminium, matte black or white finish
Dimensions:	299 x 217 x 333mm / 11.8 x 8.5 x 13.1"
Cooling:	Fanless Cooling
IP rating:	IP65
Net Weight:	3.2kg / 7.1 lbs
Rigging:	1x Omega bracket with 1/4 turn quick locks

Optional Accessories

PAR12X20HIPBD -[WH]

Rotatable Barn Doors with base, gel frame, frost and safety loop



PAR12GELFR

Gel frame for PAR12H/Q/VW



PAR12FROST

Frost filter for PAR12H/Q/VW



Lux @ 22°

	1.0m	2.0m	3.0m	4.0m	5.0m
R	8,000	2,000	981	557	411
G	12,680	3,480	1,630	963	670
B	2,600	660	350	195	142
W	16,800	4,730	2,080	1,255	883
A	13,300	3,510	1,630	961	662
U	510	170	92	44	31
Full	48,000	12,700	5,790	3,370	2,340

Road Case (Optional)

PAR12X20HIPCASE

Road Case to suit 6 units of PAR12X20H-IP Par Cans



PAR9X12H-IP [-WH] / PAR9X12BH-IP [-WH]

OUTDOOR PAR / OUTDOOR PAR BATTERY OPERATED

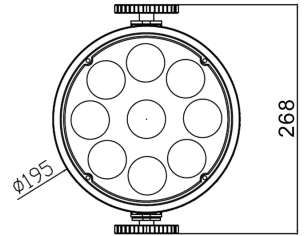
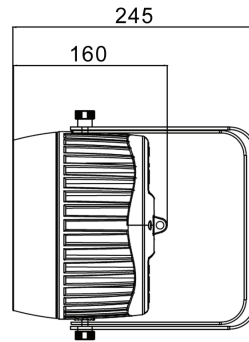

Photometrics	PAR9X12H-IP	PAR9X12BH-IP
Light Source:	9x 12 W RGBWAU LED	
Beam Angle:	25°	
Output:	2,840 lux @ 2m / 6.6ft full on	
PWM:	20,000 Hz	
Led lifespan:	50,000 hours	
Effects		
Dimming:	0~100%	
Strobe:	1~20 Hz	
Power		
Power consumption:	72W Max	
Input Voltage:	100V~240 V AC, 50/60Hz	
Connection:	True1 in/out	
Battery operating time	N/A	16 hours (1 colour); 8 hours (colour fading)
Control		
Control Protocol:	DMX512, optional WDMX	
DMX Channels:	6 / 10	
Interface:	5-pin XLR in / out	
Operational Modes:	DMX, manual, auto, sound active, master/slave	
Built-in Programming:	4 built-in auto modes	
Display	OLED touch display with glass buttons	
Housing		
Materials:	Die-cast aluminium, matte black or white finish	
Dimensions:	268 x 195 x 245 mm / 10.6 x 7.7 x 9.6"	
Cooling:	Fanless Cooling	
IP rating:	IP65	
Net Weight:	3.9kg / 8.6 lbs	4.8 kg / 10.6 lbs



Lux @ 25°					
	1.0m	2.0m	3.0m	4.0m	5.0m
R	1,750	428	186	109	71
G	3,120	738	340	188	120
B	3,320	756	350	194	125
W	4,230	960	446	252	162
A	724	168	80	46	32
U	1,020	225	115	65	43
Full	12,510	2,840	1,330	710	490

Road Case (Optional)

PAR9CASEWC

Road Case to suit 6 units of PAR9X12H-IP Par Cans



Road Case (Optional)

PAR9X12OBC

Charging Road Case to suit 6 units of PAR9X12BH-IP Par Cans



PAR12X12L / PAR12X12LW / PAR12X8L [-WH]

INDOOR LITE SERIES PAR

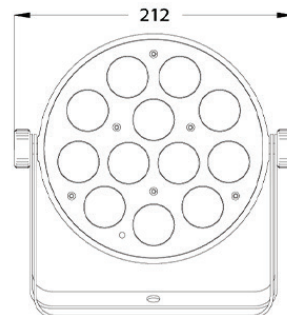
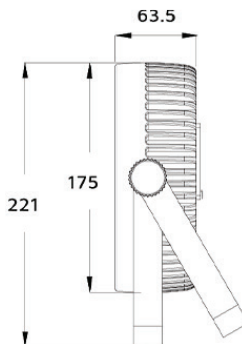

Photometrics	PAR12X12L / PAR12X12LW	PAR12X8L
Light Source:	12x 12W RGBWAW 6-in-1 LED	12x 8W RGBW 4-in-1 LED
Beam Angle:	40°	
Output:	2,580 lux @ 2m / 6.6ft full on	4,950 lux @ 2m / 6.6ft full on
PWM:	2,000 Hz	
Led lifespan:	50,000 hours	
Effects		
Dimming:	Dimming: 0~100%	
Strobe:	Strobe: 1 - 20 Hz	
Power		
Power consumption:	60W Max	60W Max
Input Voltage:	100-240V AC, 50/60Hz	
Connection:	IEC in/out	
Control		
Control Protocol:	DMX512	
DMX Channels:	6 / 11	4 / 9
Interface:	3-pin XLR in / out	
Operational Modes:	Modes: DMX, manual, auto, sound active, IR remote, master/slave	
Display	4-button and 4-digit LED control panel	
Housing		
Materials:	Die-cast aluminium, matte black or white finish	
Dimensions:	212 x 221 x 64 mm / 8.3 x 8.7 x 2.5"	
Cooling:	Fanless Cooling	
IP rating:	IP20	
Net Weight:	1.85 kg / 4.1 lbs	
Optional accessories:	Carry bag PAR12LBAG	



IR Remote Included:



PAR12X12L



PAR12X8L



Lux @ 40°	PAR12X12L / PAR12X12LW				
	1.0m	2.0m	3.0m	4.0m	5.0m
R	1,445	409	180	93	70
G	2,030	570	250	130	95
B	2,910	882	270	171	126
W	2,420	734	322	171	126
A	850	258	120	66	46
U	840	264	120	66	49
Full	8,550	2,580	1,123	543	423

Lux @ 40°	PAR12X8L				
	1.0m	2.0m	3.0m	4.0m	5.0m
R	3,300	850	370	230	140
G	3,700	1,055	480	290	180
B	5,500	1,626	705	415	260
W	4,200	1,265	570	335	222
Full	13,800	4,950	1,960	850	700

Optional Accessories

PAR12LBAG

Bag for 4pcs of PAR12L Series



PAR19X12L / PAR19X12L-WH

INDOOR LITE SERIES PAR



Photometrics	
Light Source:	19x 12W RGBWAWU 6-in-1 LEDs
Beam Angle:	40°
Output:	3,310 lux @ 2m / 6.6ft full on
PWM:	20,000 Hz
Led lifespan:	50,000 hours
Effects	
Dimming:	0-100%
Strobe:	1-20 Hz
Power	
Power consumption:	100W Max
Input Voltage:	100V-240 V AC, 50/60Hz
Connection:	powerCON in/out
Control	
Control Protocol:	DMX512
DMX Channels:	6 / 11
Interface:	3-pin XLR in / out
Operational Modes:	DMX, manual, auto, sound active, IR remote, master/slave
Built-in Programming:	Yes
Display:	4-button and 4-digit LED control panel
Housing	
Materials:	Die-cast aluminium, matte black or white finish
Dimensions:	275 x 270 x 84 mm / 10.8 x 10.6 x 3.3"
Cooling:	Fanless Cooling
IP rating:	IP20
Net Weight:	2.8 kg / 6.2 lbs



IR Remote Included:



Lux @ 40°

	1.0m	2.0m	3.0m	4.0m	5.0m
R	2,850	650	290	162	107
G	4,310	1,112	495	286	180
B	6,290	1,340	670	385	250
W	4,850	1,278	598	349	230
A	705	170	82	43	32
U	2,460	695	325	186	124
Full	12,730	3,310	1,436	845	545

Optional Accessories

PAR19LBAG

Bag for 2pcs of PAR19L Series Par with clamps



PIXBAR12H / PIXBAR12Q / PIXBAR12VW -[WH]

INDOOR PIXEL BAR

PIXEL BARS



Magnets built in

Photometrics	PIXBAR12H	PIXBAR12Q	PIXBAR12VW
Light Source:	12x 12 W RGBW LED	2x 12 W RGBW LED	12 x 6W CW/WW/A LED
Beam Angle:	30° (optional: 55°)	22° (optional: 55°)	25° (optional: 8°, 15°, 50°)
Output:	2,050 lux @ 2m / 6.6ft full on	2,550 lux @ 2m / 6.6ft full on	4,350 lux @ 2m / 6.6ft full on
PWM:	12,000 Hz		
Led lifespan:	50,000 hours		
Effects			
Dimming:	4 x 16-bit Dimming Curves		
Strobe:	1~30 Hz		
Power			
Power consumption:	150W Max	120W Max	75W Max
Input Voltage:	100~240 V AC, 50/60 Hz		
Connection:	True1 in/out		
Control			
Control Protocol:	DMX512, optional WDMX		
DMX Channels:	3 / 4 / 4A / 8 / 12 / 24 / 72 / 74	3 / 4 / 6 / 8 / 9 / 12 / 16 / 24 / 48 / 50	1 / 2 / 3 / 10 / 12 / 12P / 36 / 38
Interface:	3-pin and 5-pin XLR in/out		
Operational Modes:	DMX, manual, auto, sound active, master/slave, multi fixture chase		
Display	4-button LCD control panel		
Housing			
Materials:	Aluminium, matte black or white finish		
Dimensions:	1050 x 165 x 80 mm / 41.3 x 6.5 x 3.1"		
Cooling:	Fanless Cooling		
IP rating:	IP20		
Net Weight:	4.5 kg / 9.9 lbs		
Accessories included:	Frost filter, Barn door		



Lux @ 30°	PIXBAR12H				
	1.0m	2.0m	3.0m	4.0m	5.0m
R	913	375	190	119	87
G	1,164	486	250	156	113
B	1,157	468	240	154	109
W	1,706	678	351	219	158
A	673	257	135	189	67
U	290	116	59	36	26
Full	5,180	2,050	1,067	660	471

Lux @ 30°	PIXBAR12Q				
	1.0m	2.0m	3.0m	4.0m	5.0m
R	1,540	640	335	215	145
G	1,432	590	320	206	140
B	1,515	664	370	240	169
W	1,930	850	480	310	210
Full	5,700	2,550	1,410	890	630

Lux @ 25°	PIXBAR12VW				
	1.0m	2.0m	3.0m	4.0m	5.0m
CW	4,400	1,850	1,090	680	513
WW	3,840	1,720	927	593	446
A	2,070	966	539	335	257
Full	10,050	4,350	2,320	1,565	1,180

ACCESSORIES INCLUDED: • Barn Door • Frost Filter



Road Case (Optional)

PIXBAR12CASE6WC
Road Case to suit 6 pcs
PIXBAR12 including
clamps



PIXBAR6H / PIXBAR6Q / PIXBAR6VW -[WH]

INDOOR PIXEL BAR



Magnets built in

Photometrics	PIXBAR6H	PIXBAR6Q	PIXBAR6VW
Light Source:	6 x 12 W RGBW LED	6 x 12 W RGB LED	6 x 6W CW/WW/A LED
Beam Angle:		30° (optional: 55°)	
Output:	1,280 lux @ 2m / 6.6ft full on	N/A	2,070 lux @ 2m / 6.6ft full on
PWM:		12,000 Hz	
Led lifespan:		50,000 hours	
Effects			
Dimming:		4 Dimming Curves	
Strobe:		1~30 Hz	
Power			
Power consumption:		60W Max	
Input Voltage:		100~240 V AC, 50/60 Hz	
Connection:		True1 in/out	
Control			
Control Protocol:		DMX512, optional WDMX	
DMX Channels:	3 / 4W / 4A / 6 / 8 / 12 / 36 / 38	3 / 4W / 6 / 8 / 12 / 36 / 38	1 / 2 / 3 / 10 / 12 / 12P / 36 / 38
Interface:		5-pin XLR in/out	
Operational Modes:		DMX, manual, auto, sound active, master/slave, multi fixture chase	
Display		4-button LCD control panel	
Housing			
Materials:		Aluminium, matte black or white finish	
Dimensions:		568 x 165 x 80 mm / 22.4 x 6.5 x 3.1	
Cooling:		Fanless Cooling	
IP rating:		IP 20	
Net Weight:		2.6 kg / 5.7 lbs	
Accessories included:		Frost filter, Barn door	



Lux @ 30°		PIXBAR6H					
		1.0m	2.0m	3.0m	4.0m	5.0m	
R		783	231	104	63	48	
G		992	305	137	82	60	
B		950	292	132	80	58	
W		1,352	422	189	115	81	
A		482	157	73	47	35	
U		251	76	34	21	15	
Full		4,000	1,280	575	347	235	

ACCESSORIES INCLUDED: • Barn Door • Frost Filter



Road Case (Optional)

PIXBAR6CASEWC
Road Case to suit 6 units PIXBAR6 with 100mm tall clamps



PANX44 / PANX44-WH

INDOOR PIXEL PANEL

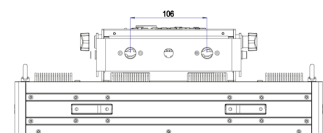
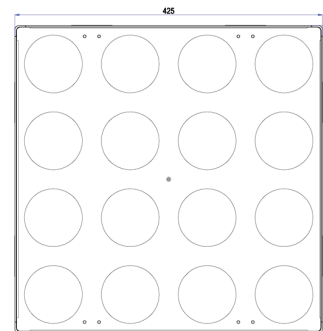
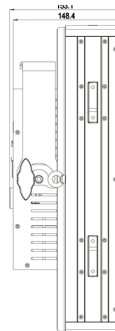
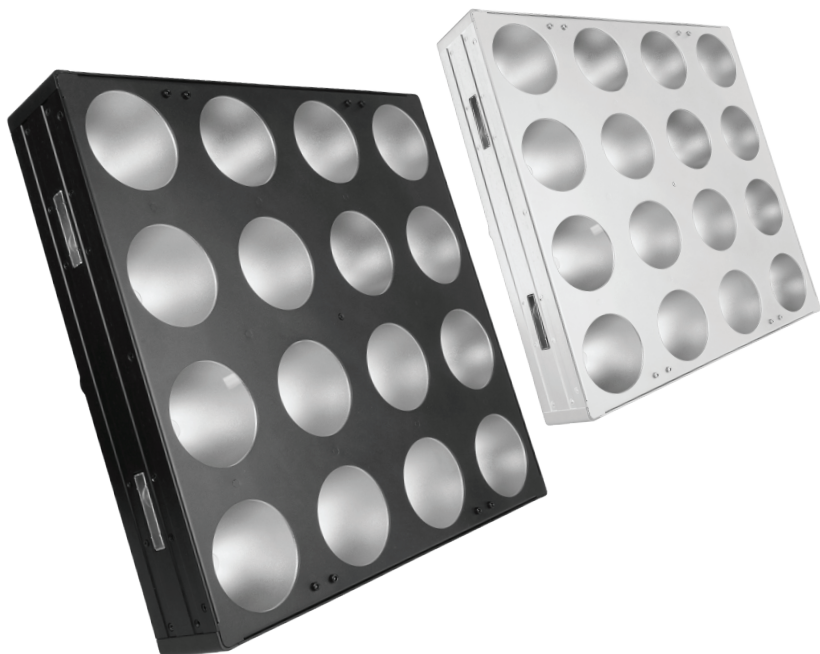

Photometrics

Light Source:	4 x 4 40W RGB+CW+WW COB LEDs
Beam Angle:	40°
Field Angle:	60°
Output:	9,100 lux @ 2m / 6.6ft full on
PWM:	1,200 Hz
Led lifespan:	50,000 hours

Effects

Dimming:	5 x 16-bit Dimming Curves
Strobe:	1~25 Hz

Power

Power consumption:	400W Max
Input Voltage:	100~240 V AC, 50/60 Hz
Connection:	True1 in/out

Control

Control Protocol:	DMX512, optional WDMX
DMX Channels:	1 / 2 / 3 / 4CW / 4WW / 8 / 11 / 82
Interface:	3-pin and 5-pin XLR in/out
Operational Modes:	DMX, manual, auto, sound active, master/slave, multi fixture chase, WDMX (optional)
Display	4-button LCD control panel
Software Upgrade via DMX:	Yes

Housing

Materials:	Aluminium, matte black or white finish
Cooling:	4 Fans
IP rating:	IP20
Dimensions:	425 x 425 x 141 mm / 16.7 x 16.7 x 5.6"
Net Weight:	10.7 kg / 23.6 lbs
Rigging:	1x Omega bracket with 1/4 turn quick locks Coffin Latch - All Sides with Hex key (included)

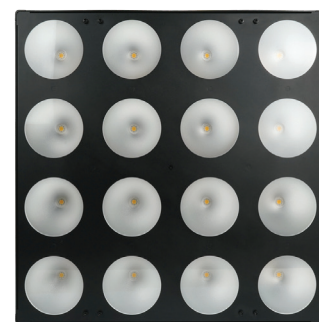

Lux @ 40°	PANX44				
	1.0m	2.0m	3.0m	4.0m	5.0m
R	3,295	1,020	440	275	175
G	6,925	2,120	990	590	390
B	1,395	430	200	125	80
CW	10,086	3,260	1,550	935	610
WW	7,765	2,500	1,190	715	470
Full	28,458	9,100	4,265	2,545	1,680

Rigging Accessories (Included)

Omega bracket with 1/4 turn quick locks

Hex key



PANX41 / PANX41-WH

INDOOR PIXEL PANEL

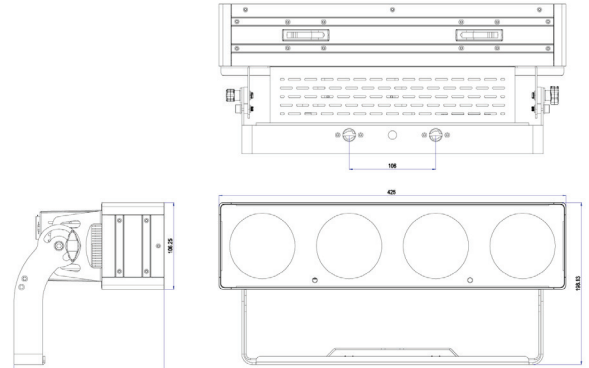

Photometrics	
Light Source:	4 x 1 40W RGB+CW+WW COB LEDs
Beam Angle:	40°
Field Angle:	60°
Output:	1,930 lux @ 2m / 6.6ft full on
PWM:	1,200 Hz
Led lifespan:	50,000 hours
Effects	
Dimming:	5 x 16-bit Dimming Curves
Strobe:	1~25 Hz
Power	
Power consumption:	120W Max
Input Voltage:	100~240 V AC, 50/60 Hz
Connection:	True1 in/out
Control	
Control Protocol:	DMX512, optional WDMX
DMX Channels:	1 / 2 / 3 / 4CW / 4WW / 8 / 11 / 22
Interface:	5-pin XLR in/out
Operational Modes:	DMX, manual, auto, sound active, master/slave, multi fixture chase, WDMX (optional)
Display	4-button LCD control panel
Software Upgrade via DMX:	Yes
Housing	
Materials:	Aluminium, matte black or white finish
Cooling:	Fanless
IP rating:	IP20
Dimensions:	425 x 197 x 183 mm / 16.7 x 7.8 x 7.2"
Net Weight:	4.3 kg / 9.5 lbs
Rigging:	1x Omega bracket with 1/4 turn quick locks Coffin Latch - Top+Bottom with Hex key (included)

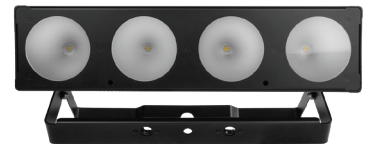

Coffin Latches



Lux @ 40°		PANX41				
	1.0m	2.0m	3.0m	4.0m	5.0m	
R	833	210	100	60	40	
G	1,645	460	210	130	90	
B	340	95	45	30	20	
CW	2,470	700	320	190	130	
WW	1,920	540	250	150	100	
Full	6,870	1,930	880	520	355	

Rigging Accessories (Included)

Omega bracket with 1/4 turn quick locks

Hex key



PANX22 / PANX22-WH

INDOOR PIXEL PANEL

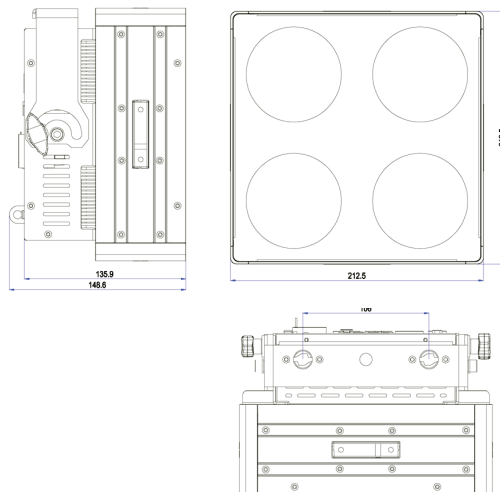
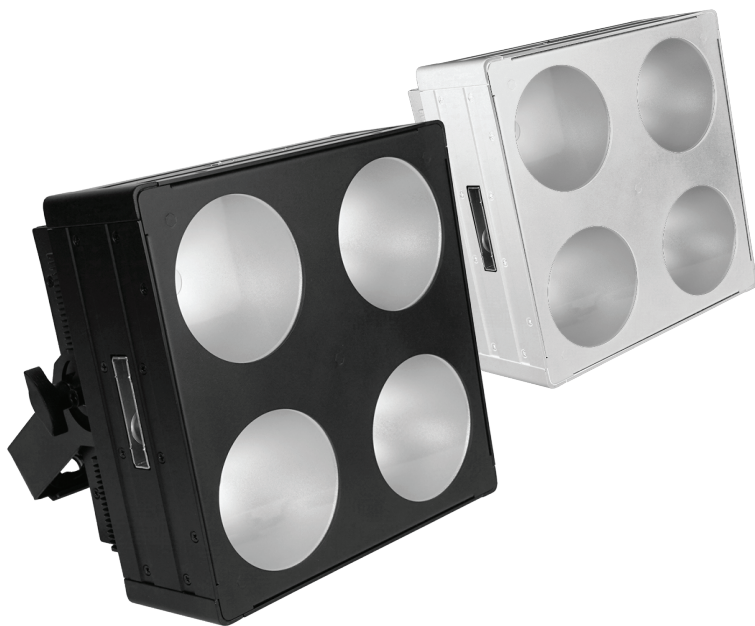

Photometrics	
Light Source:	2 x 2 40W RGB+CW+WW COB LEDs
Beam Angle:	40°
Field Angle:	60°
Output:	1,965 lux @ 2m / 6.6ft full on
PWM:	1,200 Hz
Led lifespan:	50,000 hours
Effects	
Dimming:	5 x 16-bit Dimming Curves
Strobe:	1~25 Hz
Power	
Power consumption:	120W Max
Input Voltage:	100~240 V AC, 50/60 Hz
Connection:	True1 in/out
Control	
Control Protocol:	DMX512, optional WDMX
DMX Channels:	1 / 2 / 3 / 4CW / 4WW / 8 / 11 / 22
Interface:	3-pin and 5-pin XLR in/out
Operational Modes:	DMX, manual, auto, sound active, master/slave, multi fixture chase, WDMX (optional)
Display	4-button LCD control panel
Software Upgrade via DMX:	Yes
Housing	
Materials:	Aluminium, matte black or white finish
Cooling:	Fanless
IP rating:	IP20
Dimensions:	213 x 213 x 136 mm / 8.4 x 8.4 x 5.4"
Net Weight:	3.85 kg / 8.5 lbs
Rigging:	1x Omega bracket with 1/4 turn quick locks Coffin Latch - All Sides with Hex key (included)



Coffin Latches



Lux @ 40°	PANX22					
	1.0m	2.0m	3.0m	4.0m	5.0m	
R	770	200	100	60	45	
G	1,735	460	215	126	85	
B	380	100	45	27	18	
CW	2,670	720	335	200	132	
WW	2,070	560	255	153	100	
Full	7,300	1,965	905	540	355	

Rigging Accessories (Included)

Omega bracket with 1/4 turn quick locks

Hex key



PANX21 / PANX21-WH

INDOOR PIXEL PANEL

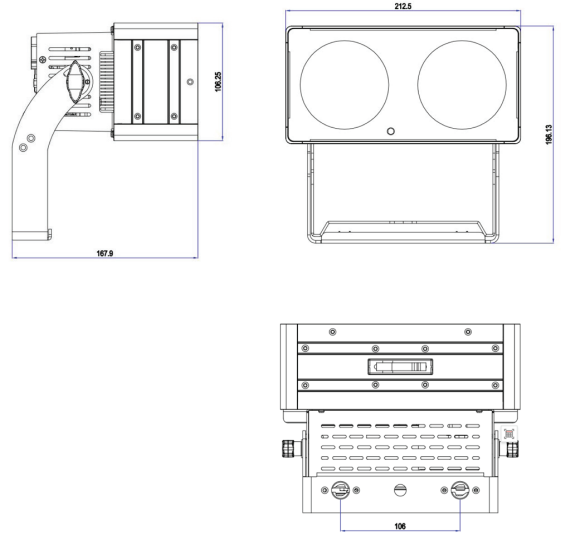

Photometrics	
Light Source:	2 x 1 40W RGB+CW+WW COB LEDs
Beam Angle:	40°
Field Angle:	60°
Output:	1,066 lux @ 2m / 6.6ft full on
PWM:	1,200 Hz
Led lifespan:	50,000 hours
Effects	
Dimming:	5 x 16-bit Dimming Curves
Strobe:	1~25 Hz
Power	
Power consumption:	50W Max
Input Voltage:	100~240 V AC, 50/60 Hz
Connection:	True1 in/out
Control	
Control Protocol:	DMX512, optional WDMX
DMX Channels:	1 / 2 / 3 / 4CW / 4WW / 8 / 11 / 12
Interface:	5-pin XLR in/out
Operational Modes:	DMX, manual, auto, sound active, master/slave, multi fixture chase, WDMX (optional)
Display	4-button LCD control panel
Software Upgrade via DMX:	Yes
Housing	
Materials:	Aluminium, matte black or white finish
Cooling:	Fanless
IP rating:	IP20
Dimensions:	213 x 168 x 197 mm / 8.4 x 6.6 x 7.6"
Net Weight:	2.5 kg / 5.5 lbs
Rigging:	1x Omega bracket with 1/4 turn quick locks Coffin Latch - Top+Bottom with Hex key (included)



Coffin Latches



Lux @ 40°		PANX21				
	1.0m	2.0m	3.0m	4.0m	5.0m	
R	476	111	50	30	20	
G	1,000	250	120	65	45	
B	201	50	22	15	5	
CW	1,500	390	175	100	65	
WW	1,134	300	130	76	50	
Full	4,137	1,066	485	275	180	

Rigging Accessories (Included)

Omega bracket with 1/4 turn quick locks

Hex key



RAINCOVERS

RAINCOVERS, CARRY BAGS

Event Lighting rain covers are the ideal way to protect your fixtures from rain or leaks during outdoor events and gigs. Made from flame retardant cloth and PC transparent soft material, they are available in a variety of sizes to suit a range of fixtures including small pars and large moving heads. Carry bags also available for rain covers.



	RAINCL	RAINCM	RAINCMS	RAINCS	RAINCPARS
Fits:	Double mount fixtures (150 mm apart)	Double mount fixtures (150 mm apart)	Single mount fixtures	Single mount fixtures	External yoke mounted fixtures
Height:	350mm / 13.8"	250mm / 9.8"	200mm / 7.9"	200mm / 7.9"	200mm / 7.9"
Upper diameter:	560mm / 22.0"	500mm / 19.7"	400mm / 15.7"	300mm / 11.8"	250mm / 9.8"
Lower diameter:	700mm / 27.6"	630mm / 24.8"	500mm / 19.7"	400mm / 15.7"	325mm / 12.8"
Materials:		PC transparent soft material			Flame retardant oxford cloth

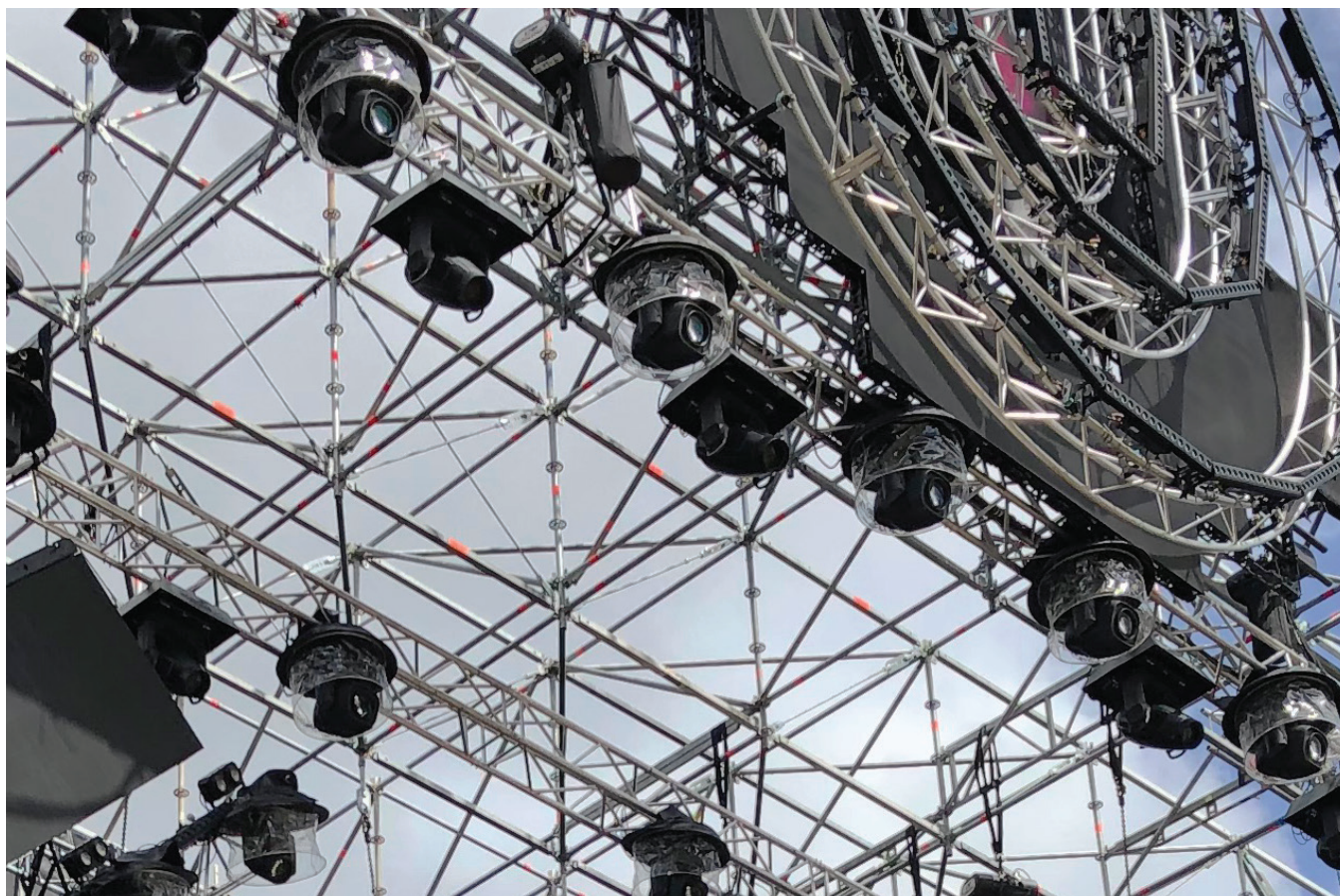

RAIN COVER CARRY BAGS

	RAINBAGL	RAINBAGM	RAINBAGS
Type:	Secure velcro seal	Secure velcro seal	Secure velcro seal
Size:	90 x 110 cm / 35.4 x 43.3"	85 x 95 cm / 33.5 x 37.4"	55 x 67 cm / 21.7 x 26.4"
Fits:	10 x RAINCL	10 x RAINCM	10 x RAINCS, RAINCPARS or RAINCMS

ROAD CASES

Event Lighting provides specially designed road cases for most of our lighting fixtures. Our Road Cases generally feature:

- Padlock-able latches
- Recessed spring return handles & latches
- Heavy duty 5 ply construction
- Heavy duty casters with brake diagonally opposite each other
- Casters mounted to extra support ply for added strength
- Black textured laminate finish, easy to clean
- High density foam
- Stackable

Some cases may not meet the above specifications.

* We can also design, manufacture and provide custom cases to suit any fixture or product.

Road Case	For	Fits
HAVOCH600FCASE1	HAVOCH600F	1
HAVOCH330FCASE2	HAVOCH330F	2
HAVOCH200FCASE4	HAVOCH200F	2
HAVOCB120CASE4	HAVOCB120	4
HAVOCW19X40CASE2	HAVOCW19X40	2
HAVOCW7X40CASE4	HAVOCW7X40	4
PAR5BDCASEWC	PAR5 with barn doors	12
PAR5CASEWC	PAR5	12
PAR12BDCASEWC	PAR12 with barn doors	8
PAR12CASEWC	PAR12	10
PAR9CASEWC	PAR9X12H-IP	6
PIXBAR12CASE6WC	PIXBAR12	6
PIXBAR6CASEWC	PIXBAR6	6
F96VWCASE	F96VW	6

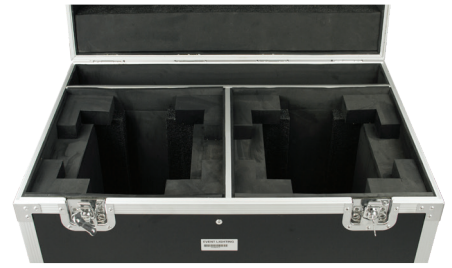

PLYWOOD RACK CASES



RACKP2RU

2RU Plywood Rack case

Dimensions	670 x 570 x 180mm / 26.4 x 22.4 x 7.1"
Weight	10.95 kg / 24.14 lbs
Included	6 Cage Nuts + 6 Screws

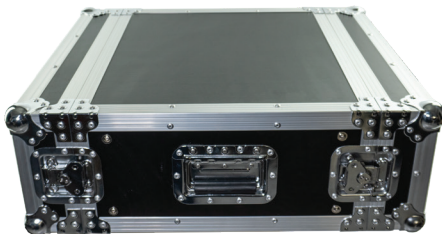

RACKP4RU

4RU Plywood Rack case

Dimensions	670 x 570 x 260mm / 26.4 x 22.4 x 10.2"
Weight	14.3 kg / 31.5 lbs
Included	12 Cage Nuts + 12 Screws



RACKP6RU

6RU Plywood Rack case

Dimensions	670 x 570 x 340mm / 26.4 x 22.4 x 13.4"
Weight	16.7 kg / 36.8 lbs
Included	18 Cage Nuts + 18 Screws

T3BL*

290MM / 11.4" SPIGOT BOX TRUSS LADDER STYLE, 2MM / 0.08" WALL THICKNESS

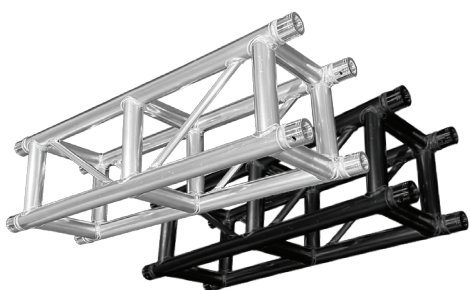

SPECIFICATIONS

T3BL*	
Main Tube:	50mm x 2mm / 2" x 0.08"
Vice Brace:	50mm x 2mm / 2" x 0.08"
Diagonal Brace:	20mm x 2mm / 0.8" x 0.08"
Materials:	Aluminum alloy 6061-T6
Finishing:	Washed or Black coated
Rating:	TUV
Length: metres	0.29 / 0.42 / 0.5 / 1 / 1.5 / 2 / 2.5 / 3 / 4
Length: feet	0.95 / 1.4 / 1.6 / 3.3 / 4.9 / 6.6 / 8.2 / 9.8 / 13.1

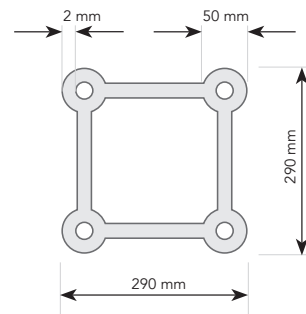

Load Chart T3BL* Series (2mm / 0.08" Main Tube). Truss diagonales must be vertical.

SPAN M	UNIFORM LOAD (KG/M)	CENTRE POINT LOAD (KG)	1/3 POINTS LOAD (KG)	1/4 POINTS LOAD (KG)
2	950	1300	1000	700
3	750	1200	900	650
4	550	1000	750	560
5	400	800	630	440
6	250	700	570	385
7	200	600	500	330
8	150	500	400	280
9	120	400	370	245
10	95	350	320	220
11	80	320	270	190
12	70	300	250	175

T3BL*H

290MM / 11.4" SPIGOT BOX TRUSS LADDER STYLE, 3MM / 0.1" WALL THICKNESS

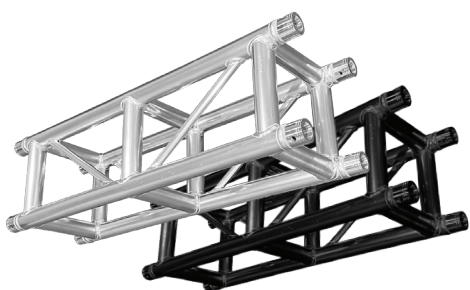

SPECIFICATIONS

T3BL*H	
Main Tube:	50mm x 3mm / 2" x 0.1"
Vice Brace:	50mm x 2mm / 2" x 0.08"
Diagonal Brace:	20mm x 2mm / 0.8" x 0.08"
Materials:	Aluminum alloy 6061-T6
Finishing:	Washed or Black coated
Rating:	TUV
Length: metres	0.29 / 0.42 / 0.5 / 1 / 1.5 / 2 / 2.5 / 3 / 4 m
Length: feet	0.95 / 1.4 / 1.6 / 3.3 / 4.9 / 6.6 / 8.2 / 9.8 / 13.1

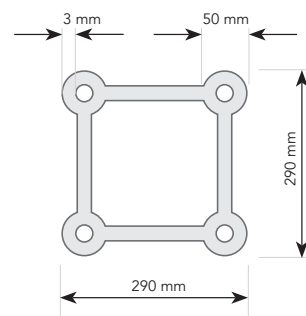

Load Chart T3BL*H Series (3mm / 0.1" Main Tube). Truss diagonales must be vertical.

SPAN (M)	2m	3m	4m	5m	6m	7m	8m	9m	10m	11m	12m
Centre Point Load (kg)											
	2269	1682	1267	1041	715	550	525	455	408	384	360
Deflection (mm)	2	6	10	13	20	30	35	45	65	87	110
Uniform Load (kg)											
	1900	1679	1410	1236	1165	1000	825	750	700	650	600
Deflection (mm)	2	7	12	20	28	35	40	86	106	120	133

T4BL*

400MM / 15.7" SPIGOT BOX TRUSS LADDER STYLE, 3MM / 0.1" WALL THICKNESS

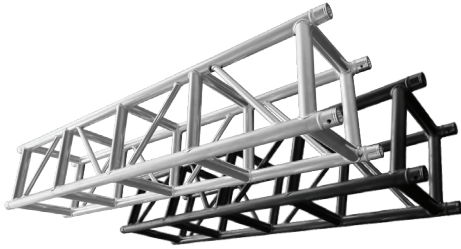

SPECIFICATIONS

T4BL*	
Main Tube:	50mm x 3mm / 2" x 0.1"
Vice Brace:	50mm x 2mm / 2" x 0.08"
Diagonal Brace:	25mm x 2mm / 1" x 0.08"
Materials:	Aluminum alloy 6061-T6
Finishing:	Washed or Black coated
Rating:	TUV
Length: metres	0.2 / 0.5 / 1 / 1.5 / 2 / 2.5 / 3 / 4
Length: feet	0.95 / 1.6 / 3.3 / 4.9 / 6.6 / 8.2 / 9.8 / 13.1

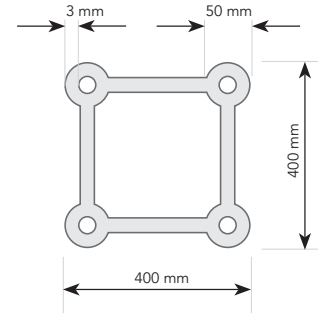

Load Chart T4BL* Series (3mm / 0.1" Main Tube). Truss diagonals must be vertical.

SPAN (M)	1m	2m	3m	4m	5m	6m	7m	8m	9m	10m	11m	12m	13m	14m	15m	16m
Centre Point Load (kg)																
	2011	1950	1859	1770	1589	1297	1100	980	910	835	755	697	600	520	479	443
Deflection (mm)	2	4	8	11	16	25	38	45	60	73	85	103	125	143	167	187
Uniform Load (kg)																
	2779	2712	2689	2605	2475	2300	1850	1650	1435	1257	1129	935	885	825	787	698
Deflection (mm)	2.5	4	5.8	10	14	20	27	36	49	60	70	87	101	115	132	147

T2BL*

220MM / 8.7" SPIGOT BOX TRUSS, 2MM / 0.08" WALL THICKNESS

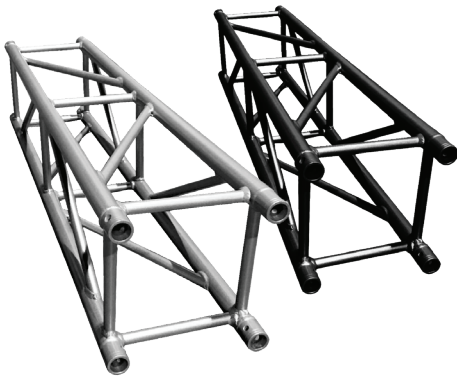

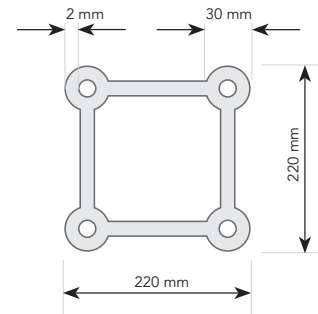

SPECIFICATIONS

T2BL*	
Main Tube:	30mm x 2mm / 1.2" x 0.08"
Vice Brace:	16mm x 2mm / 0.6" x 0.08"
Diagonal Brace:	16mm x 2mm / 0.6" x 0.08"
Materials:	Aluminum alloy 6061-T6
Finishing:	Washed or Black coated
Rating:	TUV
Length: metres	0.28 / 0.5 / 1 / 1.5 / 2 / 2.5 / 3
Length: feet	0.92 / 1.6 / 3.3 / 4.9 / 6.6 / 8.2 / 9.8



Load Chart T2BL* Series (2mm / 0.08" Main Tube)

SPAN (M)	1m	2m	3m	4m	5m	6m	7m	8m	9m	10m
Centre Point Load (kg)										
	382	378	345	260	205	169	142	123	105	95
Deflection (mm)	1	3	7	12	20	30	45	55	70	85
Uniform Load (kg)										
	382	378	377	376	339	280	235	205	177	155
Deflection (mm)	1	3	5	10	15	27	35	47	55	70

T3B5L*

290MM / 11.4" SPIGOT 5-CHORD BOX TRUSS, 3MM / 0.1" WALL THICKNESS

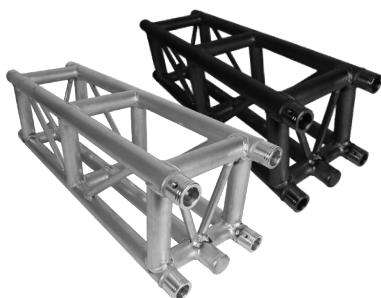

SPECIFICATIONS

T3B5L*	
Main Tube:	50mm x 3mm / 2" x 0.1"
Vice Brace:	50mm x 2mm / 2" x 0.08"
Diagonal Brace:	20mm x 2mm / 0.8" x 0.08"
Materials:	Aluminum alloy 6061-T6
Finishing:	Washed or Black coated
Rating:	TUV
Length: metres	0.5 / 1 / 1.5 / 2 / 2.5 / 3 / 4
Length: feet	1.6 / 3.3 / 4.9 / 6.6 / 8.2 / 9.8 / 13.1

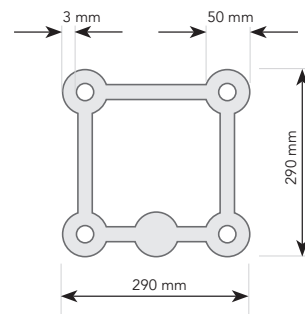

Load Chart T3B5L* Series (3 mm / 0.1" Main Tube). Fifth chord must face down.

SPAN (M)	UNIFORM LOAD (KG/M)	CENTRE POINT LOAD (KG)	1/3 POINTS LOAD (KG)	1/4 POINTS LOAD (KG)
2	1000	1300	1000	800
3	800	1200	950	750
4	550	1000	850	700
5	450	800	800	650
6	350	750	750	600
7	300	700	700	550
8	250	650	650	500
9	200	600	580	420
10	160	550	480	350
11	100	500	380	250
12	70	420	280	210

T4B5L*

400MM / 15.7" SPIGOT 5-CHORD BOX TRUSS, 3MM / 0.1" WALL THICKNESS

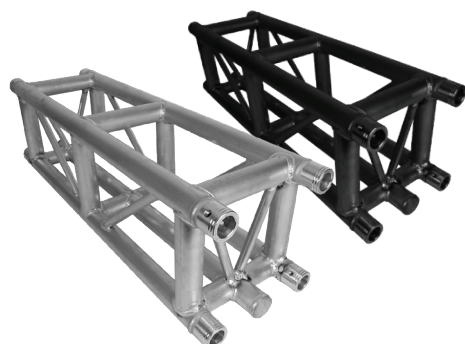

SPECIFICATIONS

T4B5L*	
Main Tube:	50mm x 3mm / 2" x 0.1"
Vice Brace:	50mm x 2mm / 2" x 0.08"
Diagonal Brace:	25mm x 2mm / 1" x 0.08"
Materials:	Aluminum alloy 6061-T6
Finishing:	Washed or Black coated
Rating:	TUV
Length: metres	0.5 / 1 / 1.5 / 2 / 2.5 / 3 / 4
Length: feet	1.6 / 3.3 / 4.9 / 6.6 / 8.2 / 9.8 / 13.1

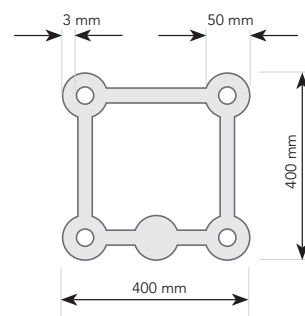

Load Chart T4B5L* Series (3mm / 0.1" Main Tube). Fifth chord must face down.

SPAN (M)	1m	2m	3m	4m	5m	6m	7m	8m	9m	10m	11m	12m	13m	14m	15m	16m
Centre Point Load (kg)																
	2011	1950	1859	1770	1589	1297	1100	980	910	835	755	697	600	520	479	443
Deflection (mm)	2	4	8	11	16	25	38	45	60	73	85	103	125	143	167	187
Uniform Load (kg)																
	2779	2712	2689	2605	2475	2300	1850	1650	1435	1257	1129	935	885	825	787	698
Deflection (mm)	2.5	4	5.8	10	14	20	27	36	49	60	70	87	101	115	132	147

T3BD*

290MM / 11.4" SPIGOT BOX TRUSS DIAGONAL STYLE, 3MM / 0.1"WALL THICKNESS

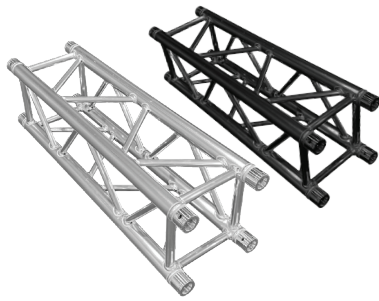

SPECIFICATIONS

T3BD*	
Main Tube:	50mm x 3mm / 2" x 0.1"
Diagonal Brace:	20mm x 2mm / 0.8" x 0.08"
Materials:	Aluminum alloy 6061-T6
Finishing:	Washed or Black coated
Rating:	TUV
Length: metres	0.5 / 1 / 1.5 / 2 / 2.5 / 3
Length: feet	1.6 / 3.3 / 4.9 / 6.6 / 8.2 / 9.8

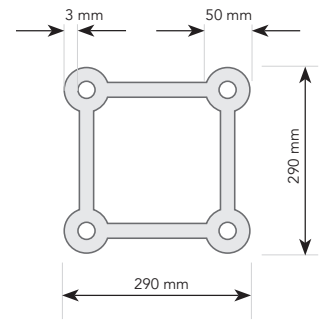

Load Chart T3BD* Series (3mm / 0.1" Main Tube)

SPAN (M)	2m	3m	4m	5m	6m	7m	8m	9m	10m	11m	12m
Centre Point Load (kg)											
	2069	1512	1147	941	645	495	475	410	368	346	320
Deflection (mm)	2	6	10	13	20	30	35	45	65	89	112
Uniform Load (kg)											
	1700	1512	1270	1113	1049	900	735	675	630	585	540
Deflection (mm)	2	7	12	20	28	35	40	86	106	122	135

T4BD*

400MM / 15.7" SPIGOT BOX TRUSS DIAGONAL STYLE, 3MM / 0.1" WALL THICKNESS

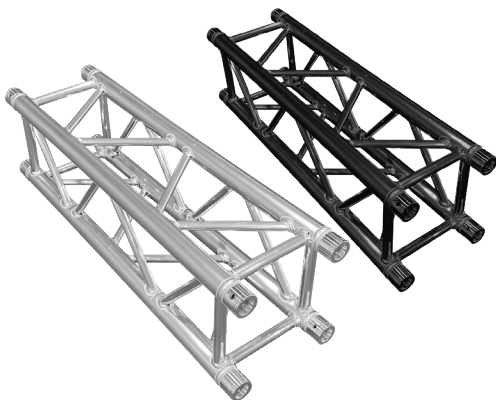

SPECIFICATIONS

T4BD*	
Main Tube:	50mm x 3mm / 2" x 0.1"
Diagonal Brace:	25mm x 2mm / 1" x 0.08"
Materials:	Aluminum alloy 6061-T6
Finishing:	Washed or Black coated
Rating:	TUV
Length: metres	0.5 / 1 / 1.5 / 2 / 2.5 / 3
Length: feet	1.6 / 3.3 / 4.9 / 6.6 / 8.2 / 9.8

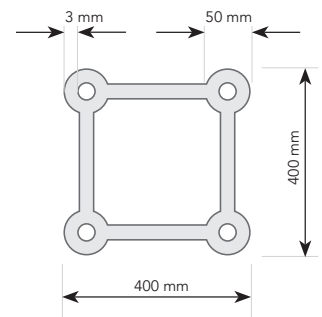

Load Chart T4BD* Series (3mm / 0.1" Main Tube)

SPAN (M)	1m	2m	3m	4m	5m	6m	7m	8m	9m	10m	11m	12m	13m	14m	15m	16m
Centre Point Load (kg)																
	2011	1950	1859	1770	1589	1297	1100	980	910	835	755	697	600	520	479	443
Deflection (mm)	2	4	8	11	16	25	38	45	60	73	85	103	125	143	167	187
Uniform Load (kg)																
	2779	2712	2689	2605	2475	2300	1850	1650	1435	1257	1129	935	885	825	787	698
Deflection (mm)	2.5	4	5.8	10	14	20	27	36	49	60	70	87	101	115	132	147

T46BL*

400 x 600MM / 15.7 x 23.6" SPIGOT RECTANGULAR TRUSS, 3MM / 0.1" WALL THICKNESS



SPECIFICATIONS

T46BL*	
Main Tube:	50mm x 3mm / 2" x 0.1"
Vice Brace:	50mm x 2mm / 2" x 0.08"
Diagonal Brace:	25mm x 2mm / 1" x 0.08"
Materials:	Aluminum alloy 6061-T6
Finishing:	Washed or Black coated
Rating:	TUV
Length: metres	0.5 / 1 / 1.5 / 2 / 2.5 / 3 / 4
Length: feet	1.6 / 3.3 / 4.9 / 6.6 / 8.2 / 9.8 / 13.1

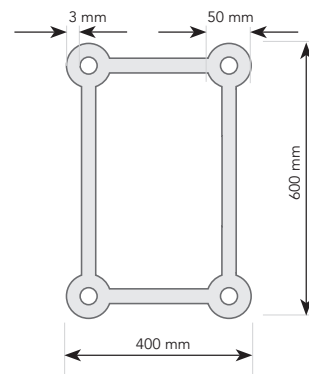

Load Chart T46BL* Series (3mm / 0.1" Main Tube). Truss diagonales must be vertical.

SPAN (M)	4m	5m	6m	7m	8m	9m	10m	11m	12m	13m	14m	15m	16m	17m	18m	19m	20m
Centre Point Load (kg)																	
	2900	2300	2000	1712	1613	1394	1135	1049	900	889	820	750	660	570	560	550	480
Deflection (mm)	12	14	15	18	26	31	40	43	46	49	53	56	72	88	110	132	138
Uniform Load (kg)																	
	2900	2300	2200	1900	1800	1550	1450	1400	1350	1200	1163	1125	1007	890	883	875	650
Deflection (mm)	12	13	18	20	24	32	40	44	48	61	74	87	90	95	112	129	136

T56BL*

500 x 600MM / 19.7 x 23.6" SPIGOT RECTANGULAR TRUSS, 3MM / 0.1" WALL THICKNESS

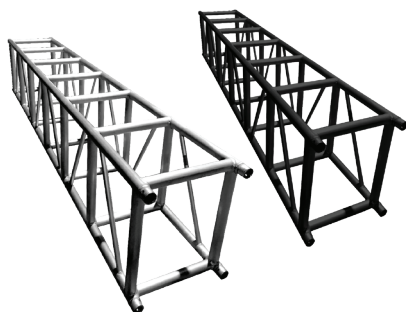

SPECIFICATIONS

T56BL*	
Main Tube:	50mm x 3mm / 2" x 0.1"
Vice Brace:	50mm x 2mm / 2" x 0.08"
Diagonal Brace:	25mm x 2mm / 1" x 0.08"
Materials:	Aluminum alloy 6061-T6
Finishing:	Washed or Black coated
Rating:	TUV
Length: metres	0.5 / 1 / 1.5 / 2 / 2.5 / 3 / 4
Length: feet	1.6 / 3.3 / 4.9 / 6.6 / 8.2 / 9.8 / 13.1

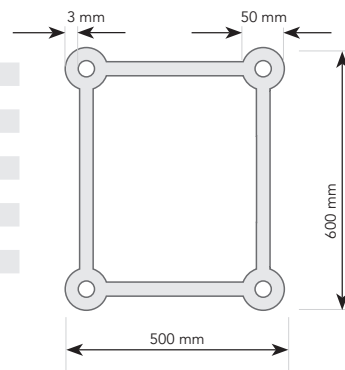

Load Chart T56BL* Series (3mm / 0.1" Main Tube). Truss diagonales must be vertical.

SPAN (M)	2m	3m	4m	5m	6m	7m	8m	9m	10m	11m	12m	13m	14m	15m	16m	17m	18m	19m	20m	21m
Centre Point Load (kg)																				
	3210	3145	3095	2495	2210	1809	1643	1424	1255	1049	900	889	820	750	660	570	560	550	480	470
Deflection (mm)	13	14	17	20	25	30	34	37	40	43	46	49	53	56	72	88	10	132	138	142
Uniform Load (kg)																				
	3210	3140	3100	2300	2210	1910	1821	1570	1445	1400	1350	1200	1163	1125	1007	890	883	857	650	639
Deflection (mm)	13	15	18	20	24	32	35	38	41	44	48	61	74	87	90	95	112	129	136	144

T57BL*

520 x 760MM / 20.5 x 29.9" SPIGOT RECTANGULAR TRUSS, 3MM / 0.1" WALL THICKNESS



SPECIFICATIONS

T57BL*	
Main Tube:	50mm x 3mm / 2" x 0.1"
Diagonal Brace:	25mm x 2mm / 1" x 0.08"
Materials:	Aluminum alloy 6061-T6
Finishing:	Washed or Black coated
Rating:	TUV
Length: metres	0.5 / 1 / 1.5 / 2 / 2.5 / 3 / 4
Length: feet	1.6 / 3.3 / 4.9 / 6.6 / 8.2 / 9.8 / 13.1

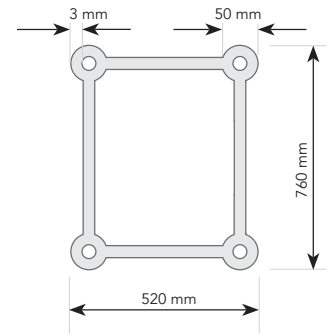

Load Chart T57BL* Series (3mm / 0.1" Main Tube). Truss diagonales must be vertical.

SPAN (M)	4m	5m	6m	7m	8m	9m	10m	11m	12m	13m	14m	15m	16m	17m	18m	19m	20m	21m	22m	23m	24m	25m	26m	27m	
Centre Point Load (kg)																									
	4000	3880	3468	2691	2396	2307	2134	1738	1356	1280	1108	1086	991	924	832	711	659	486	438	400	379	336	318	296	
Deflection (mm)	12	13	16	18	25	32	40	48	54	62	70	84	96	103	112	122	130	141	153	165	176	194	202	220	
Uniform Load (kg)																									
	4000	3880	3700	3629	2827	2760	2463	2261	2036	1800	1650	1600	1550	1400	1200	1174	1050	980	950	900	800	750	700	680	
Deflection (mm)	12	13	16	19	24	30	36	45	54	60	68	84	92	102	113	120	126	134	138	140	148	156	162	167	

T610BL*

600 x 1000MM / 23.6 x 39.4" SPIGOT RECTANGULAR TRUSS, 5MM / 0.2" WALL THICKNESS



SPECIFICATIONS

T610BL*	
Main Tube:	60mm x 5mm / 2.4" x 0.2"
Diagonal Brace:	25mm x 2mm / 1" x 0.08"
Materials:	Aluminum alloy 6061-T6
Finishing:	Washed or Black coated
Rating:	TUV
Length: metres	0.5 / 1 / 1.5 / 2 / 2.5 / 3 / 4
Length: feet	1.6 / 3.3 / 4.9 / 6.6 / 8.2 / 9.8 / 13.1

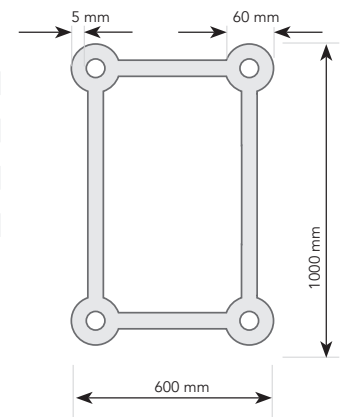

Load Chart T610BL* Series (5mm / 0.2" Main Tube). Truss diagonales must be vertical.

SPAN (M)	4m	6m	8m	10m	12m	14m	16m	18m	20m	22m	24m	26m	28m	30m	32m	34m	36m
Centre Point Load (kg)																	
	9662	7230	5392	4282	3534	2996	2587	2266	2006	1788	1604	1448	1309	1186	1078	1005	910
Deflection (mm)	5	12	20	26	40	50	68	82	101	125	145	169	195	221	253	266	300
Uniform Load (kg)																	
	11192	10974	8951	7106	5868	4973	4298	3764	3330	2970	2665	2403	2174	1971	1791	1736	1558
Deflection (mm)	5	8	16	23	30	45	55	68	80	100	115	138	156	177	200	215	241

T3TD*

290MM / 11.4" SPIGOT TRIANGULAR TRUSS, 3MM / 0.1" WALL THICKNESS

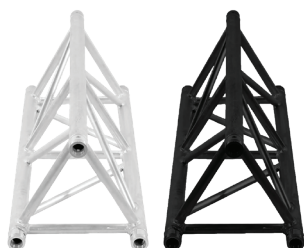

SPECIFICATIONS

T3TD*	
Main Tube:	50mm x 3mm / 2" x 0.1"
Vice Brace:	50mm x 2mm / 2" x 0.08"
Diagonal Brace:	20mm x 2mm / 0.8" x 0.08"
Materials:	Aluminum alloy 6061-T6
Finishing:	Washed or Black coated
Rating:	TUV
Length: metres	0.5 / 1 / 1.5 / 2 / 2.5 / 3
Length: feet	1.6 / 3.3 / 4.9 / 6.6 / 8.2 / 9.8

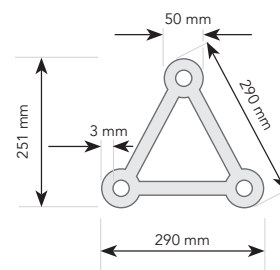

Load Chart T3TD* Series (3mm / 0.1" Main Tube)

SPAN (M)	2m	3m	4m	5m	6m	7m	8m	9m	10m	11m	12m
Centre Point Load (kg)											
	1000	730	501	446	367	305	216	158	140	124	110
Deflection (mm)	2.5	8	13	18	24	30	38	46	55	62	72
Uniform Load (kg)											
	1108	1000	820	783	600	450	421	400	342	315	298
Deflection (mm)	2	7	12	20	25	33	46	51	58	66	73

T4TD*

400MM / 15.7" SPIGOT TRIANGULAR TRUSS, 3MM / 0.1" WALL THICKNESS

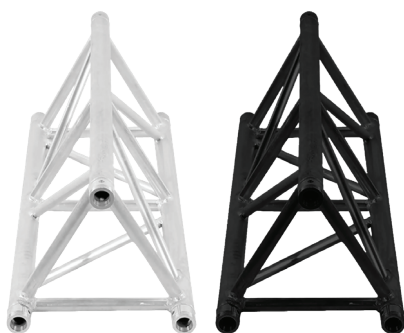

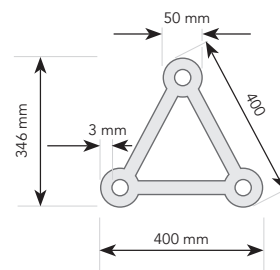

SPECIFICATIONS

T4TD*	
Main Tube:	50mm x 3mm / 2" x 0.1"
Vice Brace:	50mm x 2mm / 2" x 0.08"
Diagonal Brace:	25mm x 2mm / 1" x 0.08"
Materials:	Aluminum alloy 6061-T6
Finishing:	Washed or Black coated
Rating:	TUV
Length: metres	0.5 / 1 / 1.5 / 2 / 2.5 / 3
Length: feet	1.6 / 3.3 / 4.9 / 6.6 / 8.2 / 9.8



Load Chart T4TD* Series (3mm / 0.1" Main Tube)

SPAN (M)	1m	2m	3m	4m	5m	6m	7m	8m	9m	10m	11m	12m	13m	14m	15m	16m
Centre Point Load (kg)																
	1700	1350	1208	1106	1079	1000	901	885	801	789	798	740	709	483	632	620
Deflection (mm)	2.2	3.8	4.7	6.9	9.8	10	16	20	22	30	40	45	50	60	67	79
Uniform Load (kg)																
	3326	2645	2566	2196	2000	1956	1736	1645	1501	1456	1342	1304	1202	1176	1123	1096
Deflection (mm)	1.8	2.4	4	6	7.9	10	14	17	21	26	35	38	49	51	60	69

T3F*

290MM / 11.4" SPIGOT FLAT TRUSS

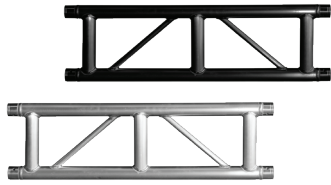

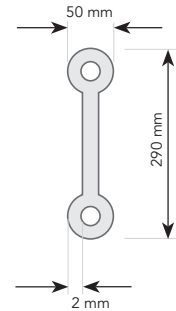

SPECIFICATIONS

T3F*	
Main Tube:	50mm x 2mm / 2" x 0.08"
Diagonal Brace:	20mm x 2mm / 0.8" x 0.08"
Materials:	Aluminum alloy 6061-T6
Finishing:	Washed or Black coated
Rating:	TUV
Length: metres	0.42 / 0.5 / 1 / 1.5 / 2 / 2.5 / 3 / 4
Length: feet	1.4 / 1.6 / 3.3 / 4.9 / 6.6 / 8.2 / 9.8 / 13.1



Load Chart T3F* Series (2mm / 0.08" Main Tube). Truss orientation must be vertical.

SPAN (M)	UNIFORM LOAD (KG/M)	CENTRE POINT LOAD (KG)
		
2	380	400
3	100	150
4	30	50
5	20	30
6	10	20

T4F*

400MM / 15.7" SPIGOT FLAT TRUSS

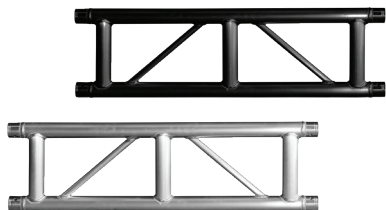

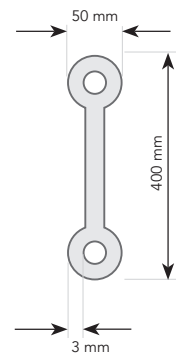

SPECIFICATIONS

T4F*	
Main Tube:	50mm x 3mm / 2" x 0.1"
Diagonal Brace:	25mm x 2mm / 1" x 0.08"
Materials:	Aluminum alloy 6061-T6
Finishing:	Washed or Black coated
Rating:	TUV
Length: metres	0.5 / 1 / 1.5 / 2 / 2.5 / 3 / 4
Length: feet	1.6 / 3.3 / 4.9 / 6.6 / 8.2 / 9.8 / 13.1



Load Chart T4F* Series (3mm / 0.1" Main Tube). Truss orientation must be vertical.

SPAN (M)	1m	2m	3m	4m	5m	6m
Centre Point Load (kg)						
	1276	544	275	140	78	53
Deflection (mm)	0	1	2	2	2	3
Uniform Load (kg)						
	1277	900	458	230	131	82
Deflection (mm)	0	1	1	1	2	2

T3BB*

300MM / 11.8" BOLT BOX TRUSS

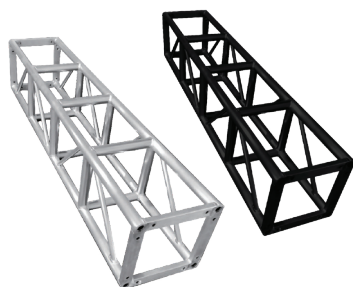

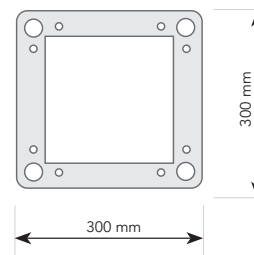

SPECIFICATIONS

T3BB*	
Main Tube:	50mm x 3mm / 2" x 0.1"
Vice Brace:	50mm x 2mm / 2" x 0.08"
Diagonal Brace:	25mm x 2mm / 1" x 0.08"
Materials:	Aluminum alloy 6061-T6
Finishing:	Washed or Black coated
Rating:	TUV
Length: metres	0.5 / 1 / 1.5 / 2 / 2.5 / 3 / 4
Length: feet	1.6 / 3.3 / 4.9 / 6.6 / 8.2 / 9.8 / 13.1



Load Chart T3BB* Series (3mm / 0.1" Main Tube). Truss diagonales must be vertical.

SPAN (M)	2m	3m	4m	5m	6m	7m	8m	9m	10m	11m	12m
Centre Point Load (kg)											
	1701	1276	900	823	627	550	480	400	300	280	250
Deflection (mm)	2	6	10	13	20	30	40	45	55	68	74
Uniform Load (kg)											
	1900	1679	1410	1236	900	750	600	550	500	480	450
Deflection (mm)	2	7	12	20	25	33	46	51	58	66	73

T4BB*

400MM / 15.7" BOLT BOX TRUSS

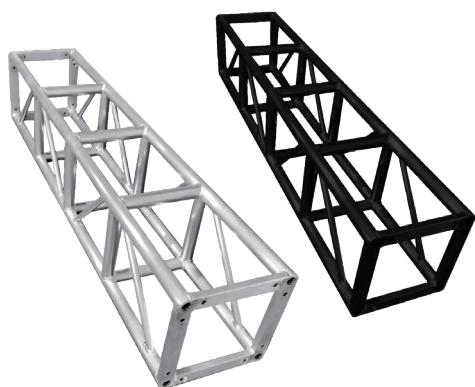

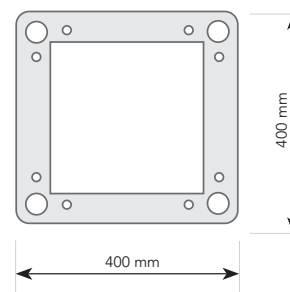

SPECIFICATIONS

T4BB*	
Main Tube:	50mm x 3mm / 2" x 0.1"
Vice Brace:	50mm x 2mm / 2" x 0.08"
Diagonal Brace:	25mm x 2mm / 1" x 0.08"
Materials:	Aluminum alloy 6061-T6
Finishing:	Washed or Black coated
Rating:	TUV
Length: metres	0.5 / 1 / 1.5 / 2 / 2.5 / 3 / 4
Length: feet	1.6 / 3.3 / 4.9 / 6.6 / 8.2 / 9.8 / 13.1



Load Chart T4BB* Series (3mm / 0.1" Main Tube). Truss diagonales must be vertical.

SPAN (M)	1m	2m	3m	4m	5m	6m	7m	8m	9m	10m	11m	12m	13m	14m	15m	16m
Centre Point Load (kg)																
	1600	1480	1400	1300	1250	1150	1050	1000	950	900	820	750	650	550	500	450
Deflection (mm)	3	5	7	15	21	30	41	52	63	75	84	93	99	106	123	140
Uniform Load (kg)																
	1700	1600	1550	1480	1400	1320	1250	1150	1100	1050	1010	960	930	900	825	750
Deflection (mm)	3	4	5	9	14	18	22	30	39	44	63	82	101	122	143	164

T3TB*

300MM / 11.8" BOLT TRIANGULAR TRUSS

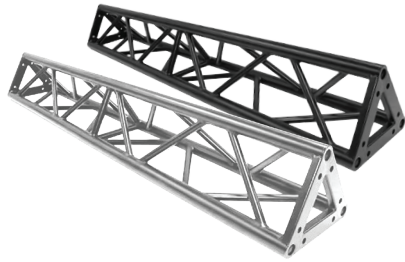

SPECIFICATIONS

T3TB*	
Main Tube:	50mm x 3mm / 2" x 0.1"
Diagonal Brace:	25mm x 2mm / 1" x 0.08"
Materials:	Aluminum alloy 6061-T6
Finishing:	Washed or Black coated
Rating:	TUV
Length: metres	0.5 / 1 / 1.5 / 2 / 2.5 / 3
Length: feet	1.6 / 3.3 / 4.9 / 6.6 / 8.2 / 9.8

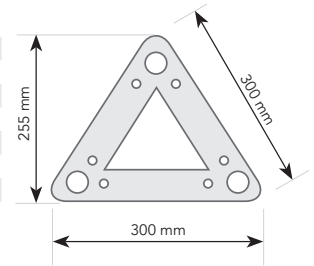

Load Chart T3TB* Series (3mm / 0.1" Main Tube)

SPAN (M)	2m	3m	4m	5m	6m	7m	8m	9m	10m	11m	12m
Centre Point Load (kg)											
	1000	730	501	446	367	305	216	158	140	124	110
Deflection (mm)											
2.5	8	13	18	24	30	38	46	55	62	72	
Uniform Load (kg)											
	1108	1000	820	783	600	450	421	400	342	315	298
Deflection (mm)											
2	7	12	20	25	33	46	51	58	66	73	

T4TB*

400MM / 15.7" BOLT TRIANGULAR TRUSS

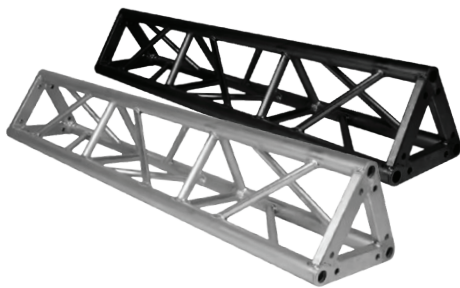

SPECIFICATIONS

T4TB*	
Main Tube:	50mm x 3mm / 2" x 0.1"
Diagonal Brace:	25mm x 2mm / 1" x 0.08"
Materials:	Aluminum alloy 6061-T6
Finishing:	Washed or Black coated
Rating:	TUV
Length: metres	0.5 / 1 / 1.5 / 2 / 2.5 / 3
Length: feet	1.6 / 3.3 / 4.9 / 6.6 / 8.2 / 9.8

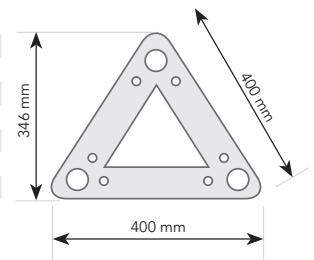

Load Chart T4TB* Series (3mm / 0.1" Main Tube)

SPAN (M)	1m	2m	3m	4m	5m	6m	7m	8m	9m	10m	11m	12m	13m	14m	15m	16m
Centre Point Load (kg)																
	1700	1350	1208	1106	1079	1000	901	885	801	789	798	740	709	483	632	620
Deflection (mm)																
2.2	3.8	4.7	6.9	9.5	10	16	20	22	30	40	45	50	60	67	79	
Uniform Load (kg)																
	3326	2645	2566	2196	2000	1956	1736	1645	1501	1456	1342	1304	1202	1176	1123	1096
Deflection (mm)																
1.8	2.4	4	6	7.9	10	14	17	21	26	35	38	49	51	60	69	

T3FB*

300MM / 11.8" BOLT FLAT TRUSS



SPECIFICATIONS

T3FB*	
Main Tube:	50mm x 3mm / 2" x 0.1"
Vice Brace:	50mm x 2mm / 2" x 0.08"
Diagonal Brace:	25mm x 2mm / 1" x 0.08"
Materials:	Aluminum alloy 6061-T6
Finishing:	Washed or Black coated
Rating:	TUV
Length: metres	0.5 / 1 / 1.5 / 2 / 2.5 / 3 / 4
Length: feet	1.6 / 3.3 / 4.9 / 6.6 / 8.2 / 9.8 / 13.1

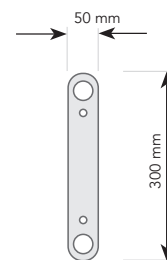

Load Chart T3FB* Series (3mm / 0.1" Main Tube). Truss orientation must be vertical.

SPAN (M)	UNIFORM LOAD (KG/M)	CENTRE POINT LOAD (KG)
2	380	400
3	100	150
4	30	50
5	20	30
6	10	20

T4FB*

400MM / 15.7" BOLT FLAT TRUSSS



SPECIFICATIONS

T4FB*	
Main Tube:	50mm x 3mm / 2" x 0.1"
Vice Brace:	50mm x 2mm / 2" x 0.08"
Diagonal Brace:	25mm x 2mm / 1" x 0.08"
Materials:	Aluminum alloy 6061-T6
Finishing:	Washed or Black coated
Rating:	TUV
Length: metres	0.5 / 1 / 1.5 / 2 / 2.5 / 3 / 4
Length: feet	1.6 / 3.3 / 4.9 / 6.6 / 8.2 / 9.8 / 13.1

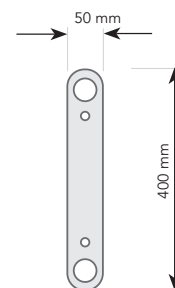

Load Chart T4FB* Series (3mm / 0.1" Main Tube). Truss orientation must be vertical.

SPAN (M)	1m	2m	3m	4m	5m	6m
Centre Point Load (kg)						
	1276	544	275	140	78	53
Deflection (mm)	0	1	2	2	2	3
Uniform Load (kg)						
	1277	900	458	230	131	82
Deflection (mm)	0	1	1	1	2	2

T46BB*

400 x 600MM / 15.7 x 23.6" BOLT RECTANGULAR TRUSS, 3MM / 0.1" WALL THICKNESS

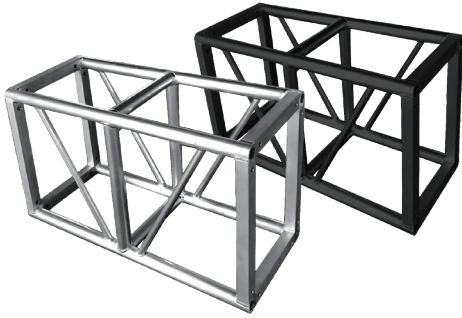

SPECIFICATIONS

T46BB*	
Main Tube:	50mm x 3mm / 2" x 0.1"
Diagonal Brace:	25mm x 2mm / 1" x 0.08"
Materials:	Aluminum alloy 6061-T6
Finishing:	Washed or Black coated
Rating:	TUV
Length: metres	0.5 / 1 / 1.5 / 2 / 2.5 / 3
Length: feet	1.6 / 3.3 / 4.9 / 6.6 / 8.2 / 9.8

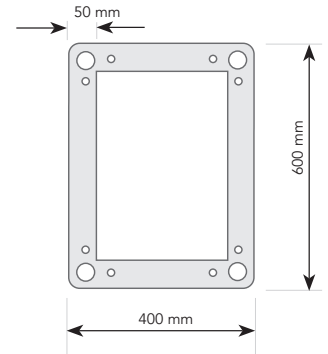

Load Chart T46BB* Series (3mm / 0.1" Main Tube). Truss diagonales must be vertical.

SPAN (M)	4m	5m	6m	7m	8m	9m	10m	11m	12m	13m	14m	15m	16m	17m	18m	19m	20m	
Centre Point Load (kg)																		
	2900	2300	2000	1712	1613	1394	1135	1049	910	910	876	886	700	612	549	543	480	
Deflection (mm)	12	14	15	18	26	31	40	46	59	66	78	91	102	110	113	126	135	
Uniform Load (kg)																		
	2900	2300	2200	1900	1800	1550	1450	1350	1250	1150	1050	1000	950	900	800	700	650	
Deflection (mm)	12	13	18	20	24	32	40	51	60	67	75	87	90	100	109	120	126	

T610BB*

600 x 1000MM / 23.6 x 39.4" BOLT RECTANGULAR TRUSS, 3MM / 0.1" WALL THICKNESS

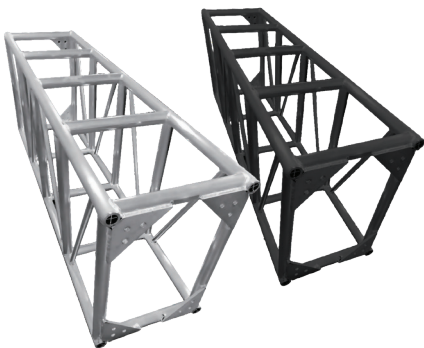

SPECIFICATIONS

T610BB*	
Main Tube:	60mm x 3mm / 2.4" x 0.1"
Diagonal Brace:	25mm x 2mm / 1" x 0.08"
Materials:	Aluminum alloy 6061-T6
Finishing:	Washed or Black coated
Rating:	TUV
Length: metres	0.5 / 1 / 1.5 / 2 / 2.5 / 3
Length: feet	1.6 / 3.3 / 4.9 / 6.6 / 8.2 / 9.8

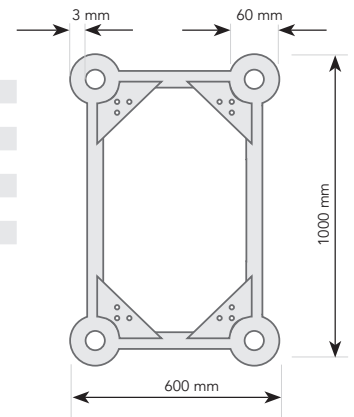

Load Chart T610BL* Series (3mm / 0.1" Main Tube). Truss diagonales must be vertical.

SPAN (M)	4m	6m	8m	10m	12m	14m	16m	18m	20m	22m	24m	26m	28m	30m	32m	34m
Centre Point Load (kg)																
	9662	7230	5392	4282	3534	2996	2587	2266	2006	1788	1604	1448	1309	1186	1078	980
Deflection (mm)	5	12	20	26	40	50	68	82	101	125	145	169	195	221	253	286
Uniform Load (kg)																
	11192	10974	8951	7106	5868	4973	4298	3764	3330	2970	2665	2403	2174	1971	1791	1626
Deflection (mm)	5	8	16	23	30	45	55	68	80	100	115	138	156	177	200	229

T55FF*

530 x 580MM / 20.7 x 22.8" SPIGOT FOLDING TRUSS



SPECIFICATIONS

T55FF*	
Main Tube:	50mm x 3mm / 2" x 0.1"
Diagonal Brace:	25mm x 2mm / 1" x 0.08"
Materials:	Aluminum alloy 6061-T6
Finishing:	Washed or Black coated
Rating:	TUV
Length: metres	0.5 / 1 / 1.5 / 2 / 2.5 / 3 / 4
Length: feet	1.6 / 3.3 / 4.9 / 6.6 / 8.2 / 9.8 / 13.1

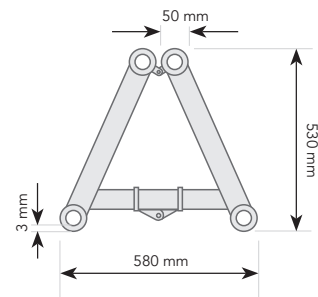

Load Chart T55FF* Series (3mm / 0.1" Main Tube)

SPAN (M)	3m	4m	5m	6m	7m	8m	9m	10m	11m	12m	13m	14m	15m	16m	17m	18m	19m	20m	21m	22m	23m	24m
Centre Point Load (kg)	2153	1749	1395	1273	1085	1030	985	879	855	832	811	745	731	675	663	617	575	567	558	520	490	454
Deflection (mm)	2	4	10	14	21	31	46	56	63	77	94	105	123	137	156	172	197	217	233	261	285	307
Uniform Load (kg)	2154	2147	2144	2112	1800	1711	1636	1461	1417	1381	1346	1235	1208	1120	1100	1021	955	940	924	866	811	758
Deflection (mm)	2	2	4	7	12	15	21	28	36	49	61	66	83	93	114	124	140	166	192	206	227	246

T610FF*

600 x 1000MM / 23.6 x 39.4" SPIGOT FOLDING TRUSS, 5MM / 0.2" WALL THICKNESS



SPECIFICATIONS

T610FF*	
Main Tube:	60mm x 5mm / 2.4" x 0.2"
Diagonal Brace:	25mm x 2mm / 1" x 0.08"
Materials:	Aluminum alloy 6061-T6
Finishing:	Washed or Black coated
Rating:	TUV
Length: metres	0.5 / 1 / 1.5 / 2 / 2.5 / 3 / 4
Length: feet	1.6 / 3.3 / 4.9 / 6.6 / 8.2 / 9.8 / 13.1

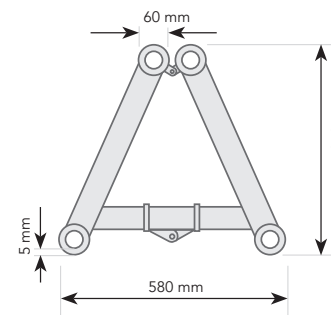

Load Chart T610FF* Series (5mm / 0.2" Main Tube)

SPAN (M)	3m	5m	7m	9m	12m	14m	17m	19m	21m	24m	26m	28m	31m	33m	36m
Centre Point Load (kg)	2070	2055	1855	1630	1460	1340	1218	1121	1041	968	908	843	807	759	718
Deflection (mm)	0.4	1	4	8	15	25	39	55	78	102	125	153	179	207	233
Uniform Load (kg)	2071	2063	1938	1634	1462	1404	1266	1120	1041	969	908	851	807	762	725
Deflection (mm)	0.5	1	7	10	19	26	41	52	75	94	118	143	171	201	237

CORNERS

FOLDING SPIGOT TRUSS CORNERS

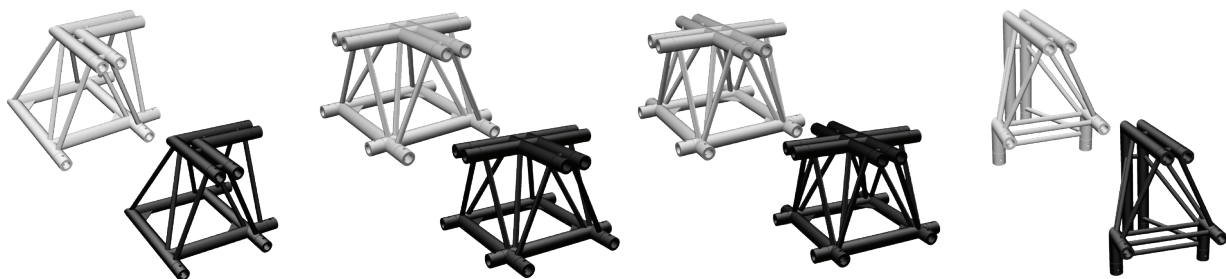

	T55FFC2 / T55FFC2BK	T55FFC3 / T55FFC3BK	T55FFC4 / T55FFC4BK	T55FFC2V / T55FFC2VBK
Fits:	530 x 580mm / 20.7 x 22.8" Spigot Folding Truss			
Type:	2-Way	3-Way	4-Way	2-Way (Vertical)
Main Tube:	50mm x 3mm / 2" x 0.1"			
Diagonal Brace:	25mm x 2mm / 1" x 0.08"			
Materials:	Aluminum alloy 6061-T6			
Finishing:	Washed or Black coated			
Rating:	TUV			

	T610FFC2 / T610FFC2BK	T610FFC3 / T610FFC3BK	T610FFC4 / T610FFC4BK	T610FFC2V / T610FFC2VBK
Fits:	600 x 1000mm / 23.6 x 39.4" Spigot Folding Truss			
Type:	2-Way	3-Way	4-Way	2-Way (Vertical)
Main Tube:	60mm x 5mm / 2.4" x 0.2"			
Diagonal Brace:	25mm x 2mm / 1" x 0.08"			
Materials:	Aluminum alloy 6061-T6			
Finishing:	Washed or Black coated			
Rating:	TUV			

• Spigots, Pins, Clips, Accessories: page 51

TRUSS TABLES & CHAIRS

TRUSS TABLES, CHAIRS, ROUNDED TOP



	TBTABLE1100BK	TBCHAIR780BK	TTTABLE1100BK	TTCHAIR780BK
Type	Box Truss Table	Box Truss Chair	Triangular Truss Table	Triangular Truss Chair
Height:	1100 mm / 43.3"	780 mm / 30.7"	1100 mm / 43.3"	780 mm / 30.7"
Top diameter:	800 mm / 31.5"	300 mm / 11.8"	800 mm / 31.5"	300 mm / 11.8"
Main tube:	50 mm / 2"			
Materials:	Aluminum alloy 6061-T6			
Finishing:	Black			

T05S*



50MM / 2" SINGLE TUBE, 2MM / 0.08" WALL THICKNESS

SPECIFICATIONS



T05S*	
Main Tube:	50mm x 2mm / 2" x 0.08"
Materials:	Aluminum alloy 6061-T6
Finishing:	Washed or Black coated
Rating:	TUV
Length: metres	0.5 / 1 / 1.5 / 2 / 2.5 / 3
Length: feet	1.6 / 3.3 / 4.9 / 6.6 / 8.2 / 9.8

Load Chart T05S* Series (2mm Main Tube)

SPAN (M)	UNIFORM LOAD (KG/M)	CENTRE POINT LOAD (KG)
		
1	220	400
2	120	120
3	40	30
4	25	12
5	15	7

CORNERS

TRUSS CUBE - HALF SPIGOTS ON 3 SIDES

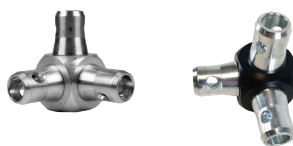

	T05SC	T05SCBK
Type:	3-Way	
Materials:	Aluminum alloy 6061-T6	
Finishing:	Washed	Black coated

CORNER BRACES

TRUSS CORNER BRACE



	TBRACE1 / TBRACE1BK	TBRACE2 / TBRACE2BK
Width:	1m	2m
Materials:	Aluminum alloy 6061-T6	
Finishing:	Washed / Black coated	Washed / Black coated

"U" SECTIONS

600MM / 23.6" WIDE - 650MM / 25.6" TALL



	TU600	TU600BK
Type:	Truss U section	
Size:	600 x 650 mm / 23.6" x 25.6"	
Materials:	Aluminum alloy 6061-T6	
Finishing:	Washed	Black coated

T3BLSPD*

290MM / 11.4" SPIGOT POWER TRUSS, 3MM / 0.1" WALL THICKNESS

Event Lighting power box truss features a chord with TRUE1 power connections, and another with 5 pin XLR DMX signal connections, thereby reducing the need cabling along trussing, allowing for a more tidy appearance within a truss set up. Power and signal input is connected to one end of the truss, with outputs spaced every 500mm for connecting fixtures. Multiple power trusses can be connected with short patch leads in between each. The power truss also features insulated rigging holes and a fuse. Also available in a flat truss version, with just the power chord.



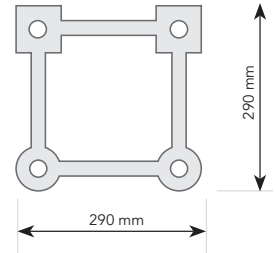

SPECIFICATIONS

T3BLSPD*	
Main Tube:	50mm x 3mm / 2" x 0.1"
Diagonal Brace:	25mm x 2mm / 1" x 0.08"
Materials:	Aluminum alloy 6061-T6
Finishing:	Washed or Black coated
Power interface:	TRUE1 in / out every half metre
XLR interface:	5-pin in/out every half metre
Protection:	Fuse
Compatibility:	290mm box truss
Mounting:	Insulated truss mounting holes
Rating:	TUV
Length: metres	1 / 2 / 3
Length: feet	3.3 / 6.6 / 9.8



Load Chart T3BLSPD* Series (3mm / 0.1" Main Tube)

SPAN (M)	2m	3m	4m	5m	6m	7m	8m	9m	10m	11m	12m
Centre Point Load (kg)											
	2269	1682	1267	1041	715	550	525	455	408	384	360
Deflection (mm)	2	6	10	13	20	30	35	45	65	87	110
Uniform Load (kg)											
	1900	1679	1410	1236	1165	1000	825	750	700	650	600
Deflection (mm)	2	7	12	20	28	35	40	86	106	120	133

T4BLSPD*

400MM / 15.7" SPIGOT POWER TRUSS, 3MM / 0.1" WALL THICKNESS



SPECIFICATIONS

T4BLSPD*	
Main Tube:	50mm x 3mm / 2" x 0.1"
Diagonal Brace:	25mm x 2mm / 1" x 0.08"
Materials:	Aluminum alloy 6061-T6
Finishing:	Washed or Black coated
Power interface:	TRUE1 in / out every half metre
XLR interface:	5-pin in/out every half metre
Protection:	Fuse
Compatibility:	400mm box truss
Mounting:	Insulated truss mounting holes
Rating:	TUV
Length: metres	1 / 2 / 3
Length: feet	3.3 / 6.6 / 9.8

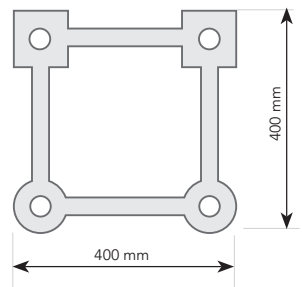

Load Chart T4BLSPD* Series (3mm / 0.1" Main Tube)

SPAN (M)	1m	2m	3m	4m	5m	6m	7m	8m	9m	10m	11m	12m	13m	14m	15m	16m
Centre Point Load (kg)																
	2011	1950	1859	1770	1589	1297	1100	980	910	835	755	697	600	520	479	443
Deflection (mm)	2	4	8	11	16	25	38	45	60	73	85	103	125	143	167	187
Uniform Load (kg)																
	2779	2712	2689	2605	2475	2300	1850	1650	1435	1257	1129	935	885	825	787	698
Deflection (mm)	2.5	4	5.8	10	14	20	27	36	49	60	70	87	101	115	132	147

T3BC*

290MM / 11.4" SPIGOT BOX TRUSS CORNER

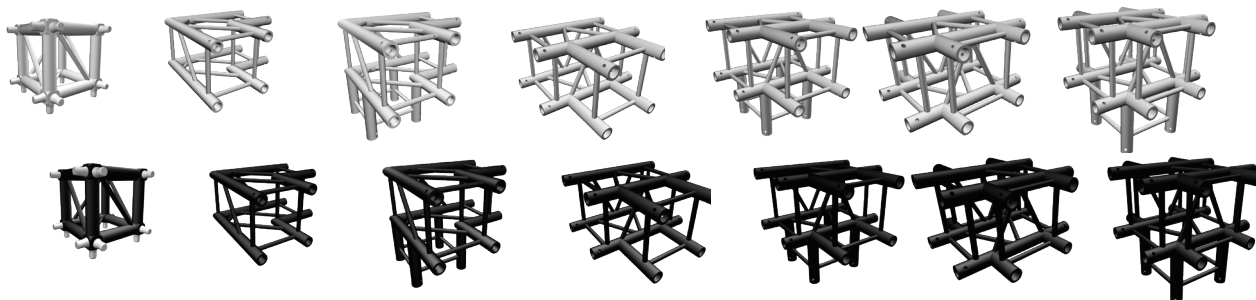

	T3BC / T3BCBK	T3BC2 / T3BC2BK	T3BC3 / T3BC3BK	T3BCT3 / T3BCT3BK	T3BCT4 / T3BCT4BK	T3BCX4 / T3BCX4BK	T3BC5 / T3BC5BK
Truss Size:	290mm / 11.4"						
Type:	Cube / universal	2 way 90 degree	3 way 90 degree	3 way - T corner	4 way - T with upright	4 way - Cross junction	4 way - cross junction with upright
Main Tube:	50mm x 3 mm / 2" x 0.1"						
Materials:	Aluminum alloy 6061-T6						
Finishing:	Washed or Black coated						

All truss corners and junctions, except for "cube" types are designed to be 500mm from truss connections.
For example T3BCT4 is 500 x 500 x 500mm / 19.7 x 19.7 x 19.7" in size, while T3BCT3 is 500 x 500 x 290mm / 19.7 x 19.7 x 11.4"

T4BC*

400MM / 15.7" SPIGOT BOX TRUSS CORNER



	T4BC / T4BCBK	T4BC2 / T4BC2BK	T4BC3 / T4BC3BK	T4BCT3 / T4BCT3BK	T4BCT4 / T4BCT4BK	T4BCX4 / T4BCX4BK	T4BC5 / T4BC5BK
Truss Size:	400mm / 15.7"						
Type:	Cube / universal	2 way 90 degree	3 way 90 degree	3 way - T corner	4 way - T with upright	4 way - Cross junction	4 way - cross junction with upright
Main Tube:	50mm x 3 mm / 2" x 0.1"						
Materials:	Aluminum alloy 6061-T6						
Finishing:	Washed or Black coated						

All pictures of corners are representative and not necessary the exact look of the final product.
These picture will help understand the shapes and purposes of these corners and junctions.

T2BC*

220MM / 8.7" SPIGOT BOX TRUSS CORNER

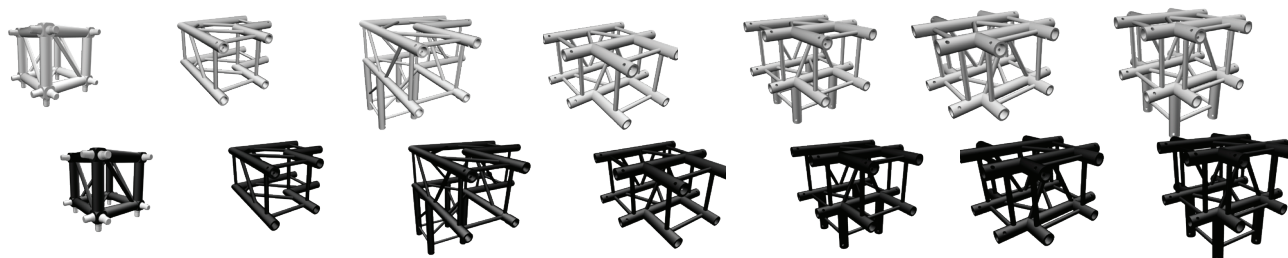

	T2BC / T2BCBK	T2BC2 / T2BC2BK	T2BC3 / T2BC3BK	T2BCT3 / T2BCT3BK	T2BCT4 / T2BCT4BK	T2BCX4 / T2BCX4BK	T2BC5 / T2BC5BK
Truss Size:	220 mm						
Type:	Cube / universal	2 way 90 degree	3 way 90 degree	3 way - T corner	4 way - T with upright	4 way - Cross junction	4 way - cross junction with upright
Main Tube:	50mm x 3 mm / 2" x 0.1"						
Materials:	Aluminum alloy 6061-T6						
Finishing:	Washed or Black coated						

T3TC* / T4TC*

290 - 400MM / 11.4 - 15.7" SPIGOT TRIANGULAR TRUSS CORNER

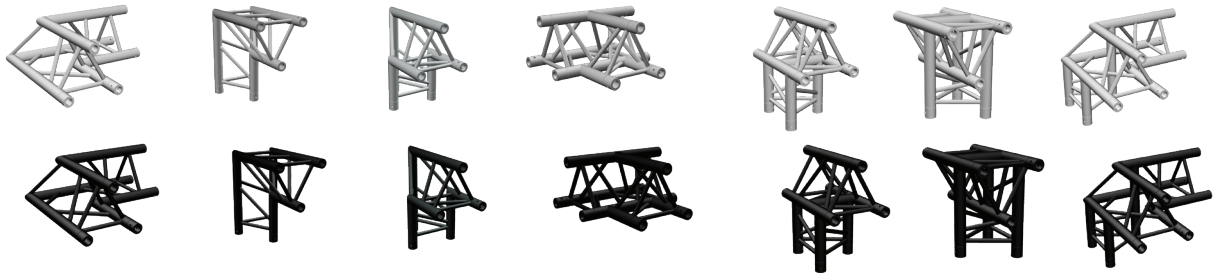

	T3TC21 / BK T4TC21 / BK	T3TC22 / BK T4TC22 / BK	T3TC23/ BK T4TC23/ BK	T3TCT3/ BK T4TCT3/ BK	T3TCT31/ BK T4TCT31/ BK	T3TCT32 / BK T4TCT32 / BK	T3TCC31L / BK T4TCC31L / BK
Truss Size:				290mm / 11.4" - T3TC* 400mm / 15.7" - T4TC*			
Type:	2 way corner	2 way corner apex in	2 way corner apex out	3 way T	3 way T upright apex up	3 way T upright apex down	3 way corner apex up, left
Main Tube:	50mm x 3 mm / 2" x 0.1"						
Materials:	Aluminum alloy 6061-T6						
Finishing:	Washed or Black coated						
Rating:	TUV						

All truss corners and junctions, except for "cube" types are designed to be 500mm from truss connections.
For example T3TCT41 is 500 x 500 x 500 / 19.7 x 19.7 x 19.7" mm in size, while T3TCT3 is 500 x 500 x 290 mm / 19.7 x 19.7 x 11.4"



	T3TCC31R / BK T4TCC31R / BK	T3TCC32L / BK T4TCC32L / BK	T3TCC32R / BK T4TCC32R / BK	T3TCX4 / BK T4TCX4 / BK	T3TCT41 / BK T4TCT41 / BK	T3TCT42 / BK T4TCT42 / BK	T3TCX41 / BK T4TCX41 / BK	T3TCX42 / BK T4TCX42 / BK
Truss Size:				290mm / 11.4" - T3TC* 400mm / 15.7" - T4TC*				
Type:	3 way corner apex up, right	3 way corner apex down, left	3 way corner apex down, right	4 way cross junction	4 way T with upright apex up	4 way T with upright, apex down	4 way cross with upright apex up	4 way cross with upright apex down
Main Tube:	50mm x 3 mm / 2" x 0.1"							
Materials:	Aluminum alloy 6061-T6							
Finishing:	Washed or Black coated							
Rating:	TUV							

All pictures of corners are representative and not necessary the exact look of the final product.
These picture will help understand the shapes and purposes of these corners and junctions.

T3FC* / T4FC

290 - 400MM / 11.4 - 15.7" SPIGOT FLAT TRUSS CORNER



	T3FC/ T3FCBK	T3FCB / T3FCBBK	T4FC/ T4FCBK	T4FCB/ T4FCBBK
Truss Size:	290mm / 11.4"		400mm / 15.7"	
Type:	Flat Truss Corner	Flat Truss Junction	Flat Truss Corner	Flat Truss Junction
Main Tube:	50mm x 3 mm / 2" x 0.1"			
Materials:	Aluminum alloy 6061-T6			
Finishing:	Washed or Black coated			
Rating:	TUV			

T3BBC* / T4BBC*

300 - 400MM / 11.8 - 15.7" BOLT BOX TRUSS CORNER

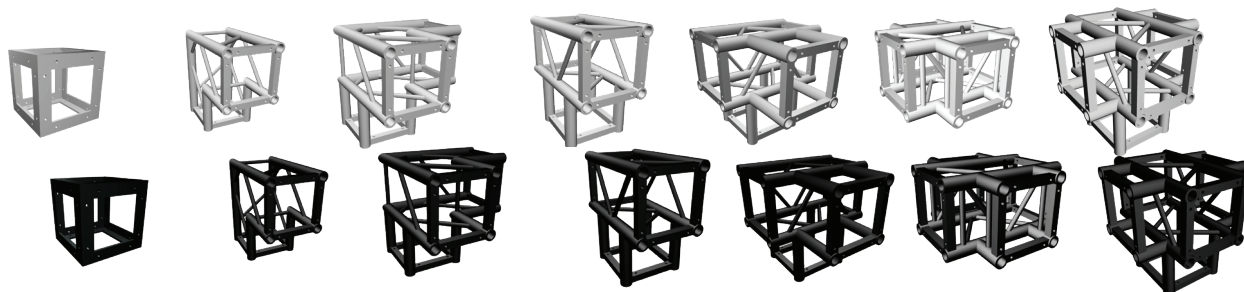

	T3BBC / BK T4BBC / BK	T3BBC2 / BK T4BBC2 / BK	T3BBC3 / BK T4BBC3 / BK	T3BBCT3 / BK T4BBCT3 / BK	T3BBCT4 / BK T4BBCT4 / BK	T3BBCX4 / BK T4BBCX4 / BK	T3BBC5 / BK T4BBC5 / BK
Truss Size:				300mm / 11.8" - T3BBC* 400mm / 15.7" - T4BBC*			
Type:	Cube / universal	2 way 90 degree	3 way 90 degree	3 way - T corner	4 way - T with upright	4 way - Cross junction	4 way - cross junction
Main Tube:	50mm x 3 mm / 2" x 0.1"						
Materials:	Aluminum alloy 6061-T6						
Finishing:	Washed or Black coated						
Rating:	TUV						

All truss corners and junctions, except for "cube" types are designed to be 500mm from truss connections.
For example T3BBC3 is 500 x 500 x 500mm / 19.7 x 19.7 x 19.7" in size, while T3BBCT3 is 500 x 500 x 290mm / 19.7 x 19.7 x 11.4"

T3FBC* / T4FBC*

300 - 400MM / 11.8 - 15.7" BOLT FLAT TRUSS CORNER



	T3FBC2 / BK T4FBC2 / BK	T3FBCV2 / BK T4FBCV2 / BK	T3FBHV3 / BK T4FBHV3 / BK	T3FBTV3 / BK T4FBTV3 / BK	T3FBXH4 / BK T4FBXH4 / BK	T3FBXV4 / BK T4FBXV4 / BK	T3FBCCUSTOM / BK T4FBCCUSTOM / BK
Truss Size:				300mm / 11.8" - T3FB* 400mm / 15.7" - T4FB*			
Type:	Horizontal right angle corner	Vertical right angle corner	Horizontal T junction	Vertical T junction	Horizontal cross junction	Vertical cross junction	Custom flat bolt truss corner/junction
Main Tube:	50mm x 3 mm / 2" x 0.1"						
Materials:	Aluminum alloy 6061-T6						
Finishing:	Washed or Black coated						
Rating:	TUV						

All pictures of corners are representative and not necessary the exact look of the final product.
These picture will help understand the shapes and purposes of these corners and junctions.

T46BBC* / T610BBC*

BOLT RECTANGULAR TRUSS JUNCTION

	T46BBC / T46BBCBK
Truss Size:	400 x 600mm / 15.7 x 23.6"
Type:	Universal cube type junction
Materials:	Aluminum alloy 6061-T6
Finishing:	Washed or Black coated
Rating:	TUV

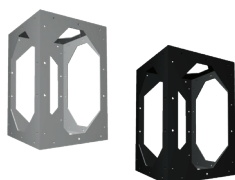

	T610BBC / T610BBCBK
Truss Size:	600 x 1000mm / 23.6 x 39.4"
Type:	Universal cube type junction
Materials:	Aluminum alloy 6061-T6
Finishing:	Washed or Black coated
Rating:	TUV

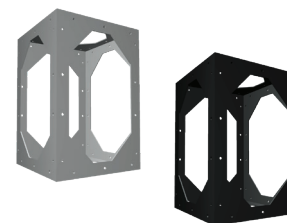

T3TBC* / T4TBC*

300 - 400MM / 11.8 - 15.7" TRIANGULAR BOLT TRUSS CORNER

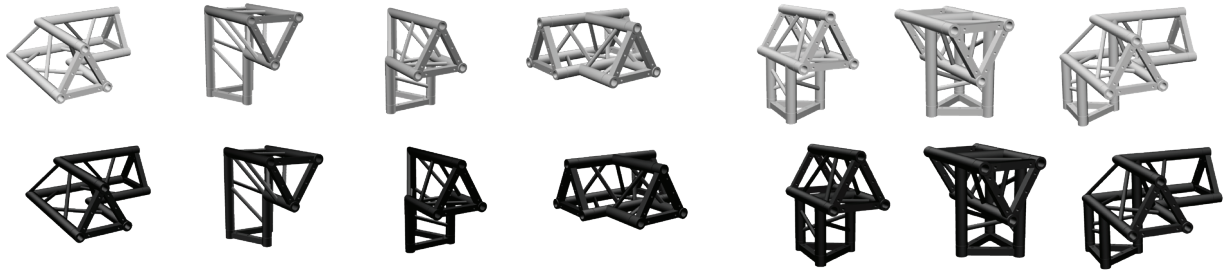

	T3TBC21 / BK T4TBC21 / BK	T3TBC22 / BK T4TBC22 / BK	T3TBC23 / BK T4TBC23 / BK	T3TBC23 / BK T4TBC23 / BK	T3TBC23 / BK T4TBC23 / BK	T3TBC23 / BK T4TBC23 / BK	T3TBC31L / BK T4TBC31L / BK
Truss Size:				300mm / 11.8" - T3TBC* 400mm / 15.7" - T4TBC*			
Type:	2 way corner apex up	2 way corner apex in	2 way corner apex out	3 way T apex up / down	3 way T upright apex up	3 way T upright apex down	3 way corner apex up, left
Main Tube:	50mm x 3 mm / 2" x 0.1"						
Materials:	Aluminum alloy 6061-T6						
Finishing:	Washed or Black coated						
Rating:	TUV						

All truss corners and junctions, except for "cube" types are designed to be 500mm from truss connections.
For example T3TBC22 is 500 x 500 x 500mm / 19.7 x 19.7 x 19.7" in size, while T3TBC23 is 500 x 500 x 290mm / 19.7 x 19.7 x 11.4"

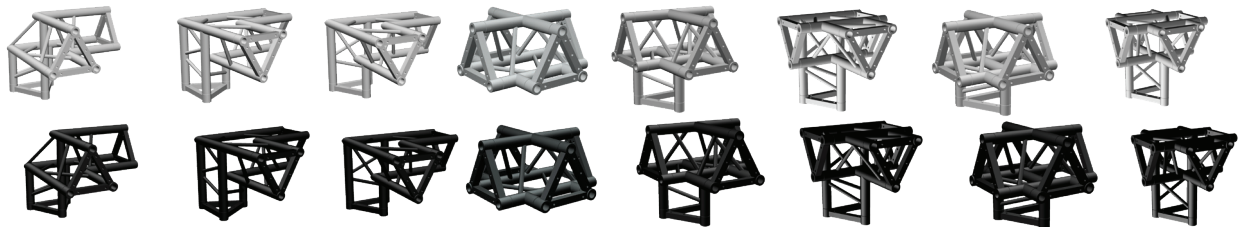

	T3TBC31R / BK T4TBC31R / BK	T3TBC32L / BK T4TBC32L / BK	T3TBC32R / BK T4TBC32R / BK	T3TBCX4 / BK T4TBCX4 / BK	T3TBC241 / BK T4TBC241 / BK	T3TBC242 / BK T4TBC242 / BK	T3TBCX41 / BK T4TBCX41 / BK	T3TBCX42 / BK T4TBCX42 / BK
Truss Size:				300mm / 11.8" - T3TBC* 400mm / 15.7" - T4TBC*				
Type:	3 way corner apex up, right	3 way corner apex down, left	3 way corner apex down, right	4 way cross junction	4 way T with upright apex up	4 way T with upright, apex down	4 way cross with upright apex up	4 way cross with upright apex down
Main Tube:	50mm x 3 mm / 2" x 0.1"							
Materials:	Aluminum alloy 6061-T6							
Finishing:	Washed or Black coated							
Rating:	TUV							

All pictures of corners are representative and not necessary the exact look of the final product.
These picture will help understand the shapes and purposes of these corners and junctions.

T*BC

SPIGOT RECTANGULAR TRUSS JUNCTION

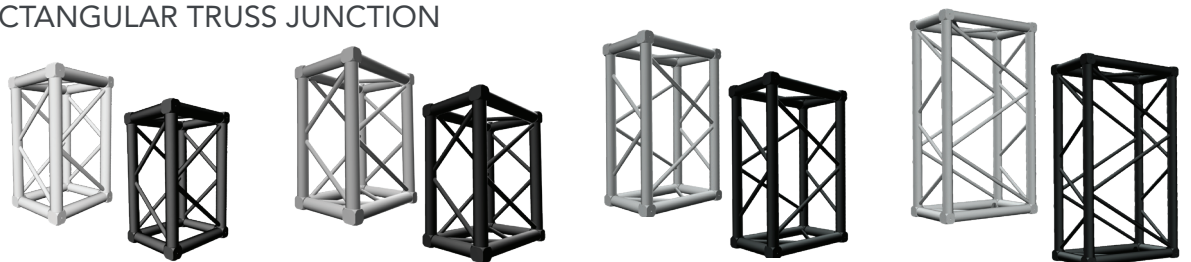

	T46BC / T46BCBK	T56BC / T56BCBK	T57BC / T57BCBK	T610BC / T610BCBK
Truss Size:	400 x 600mm / 15.7 x 23.6"	500 x 600mm / 19.7 x 23.6"	520 x 760mm / 20.5 x 29.9"	600 x 1000mm / 23.6 x 39.4"
Type:	Universal cube type junction			
Materials:	Aluminum alloy 6061-T6			
Finishing:	Washed or Black coated			
Rating:	TUV			

SIDE SUPPORT / FOLDING BASE



	3BTFEET	4BTFEET	T3BSJ/ T3BSJBK	T4BSJ/ T4BSJBK	T3FBASE / T3FBASEBK	T4FBASE / T4FBASEBK
Truss Size:	290mm / 11.4"	390mm / 15.4"	290mm / 11.4"	390mm / 15.4"	290mm / 11.4"	390mm / 15.4"
Type:	Side support feet of truss		Box Truss Spindle Junction Adjustable 450-880mm		Folding base for flat truss	
Materials:	Aluminum alloy 6061-T6					
Finishing:	Washed					
Rating:	TUV					

BASE PLATES

FOR SPIGOT TRUSS, WASHED / BLACK

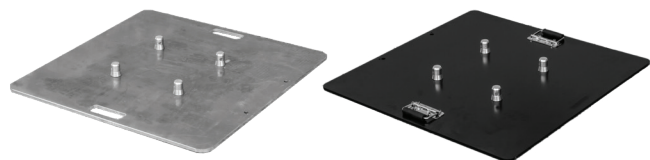

	Truss type	Fits	Size	Material
TB500A / BK	Box	290mm / 11.4"	500 x 500 mm	Aluminum
TB500A2 / BK	Box	290, 220mm / 11.4, 8.7"	500 x 500 mm	Aluminum
TB750A / BK	Box	290mm / 11.4"	750 x 750 mm	Aluminum
TB750A2 / BK	Box	290, 400mm / 11.4, 15.7"	750 x 750 mm	Aluminum
TB750A3 / BK	Box, Triangular	290, 400mm / 11.4, 15.7"	750 x 750 mm	Aluminum
TB750S / BK	Box	290mm / 11.4"	750 x 750 mm	Steel
TB750S2 / BK	Box	290, 400mm / 11.4, 15.7"	750 x 750 mm	Steel
TB750S3 / BK	Box, Triangular	290, 400mm / 11.4, 15.7"	750 x 750 mm	Steel

FOR BOLT TRUSS, WASHED / BLACK



	Truss type	Fits	Size	Material
T3BB500A / BK	Box	300mm / 11.8"	500 x 500 mm	Aluminum
T3BB750A / BK	Box	300mm / 11.8"	750 x 750 mm	Aluminum
T3BB750A2 / BK	Box	300, 400mm / 11.8, 15.7"	750 x 750 mm	Aluminum
T3BB750A3 / BK	Box, Triangular	300, 400mm / 11.8, 15.7"	750 x 750 mm	Aluminum
T3BB750S / BK	Box	300mm / 11.8"	750 x 750 mm	Steel
T3BB750S2 / BK	Box	300, 400mm / 11.8, 15.7"	750 x 750 mm	Steel
T3BB750S3 / BK	Box, Triangular	300, 400mm / 11.8, 15.7"	750 x 750 mm	Steel

END PLATES

FOR SPIGOT TRUSS, WASHED / BLACK



	Truss type	Fits	Size	Material
TB220A / BK	Box	220mm / 8.7"	220 x 220 mm	Aluminum
TB300A / BK	Box	290mm / 11.8"	290 x 290 mm	Aluminum
TB400A / BK	Box	400mm / 15.7"	400 x 400 mm	Aluminum
T3TEND / BK	Triangular	290mm / 11.8"	290 x 290 mm	Aluminum
T4TEND / BK	Triangular	400mm / 15.7"	400 x 400 mm	Aluminum
T3FEND / BK	Flat	290mm / 11.8"	290 x 290 mm	Aluminum
T4FEND / BK	Flat	400mm / 15.7"	400 x 400 mm	Aluminum

FOR BOLT TRUSS, WASHED / BLACK



	Truss type	Fits	Size	Material
T3BBEND / BK	Box	290mm / 11.8"	290 x 290 mm	Aluminum
T4BBEND / BK	Box	400mm / 15.7"	400 x 400 mm	Aluminum
T3TBEND / BK	Triangular	290mm / 11.8"	290 x 290 mm	Aluminum
T4TBEND / BK	Triangular	400mm / 15.7"	400 x 400 mm	Aluminum
T3FBEND / BK	Flat	290mm / 11.8"	290 x 290 mm	Aluminum
T4FBEND / BK	Flat	400mm / 15.7"	400 x 400 mm	Aluminum

LYCRAT*

TRUSS COVER, FITS 210MM / 8.3" , 290MM / 11.4" AND 400MM / 15.7" TRUSS

Lycra truss cover provides the perfect coverage for your truss set-ups. The lycra gives a clean look, ideal for shows, weddings, parties where trussing needs to be hidden. Zips are provided to attach fixtures to truss

Fits 290mm box	LYCRAT1W	LYCRAT2W	LYCRAT3W	LYCRAT1B	LYCRAT2B	LYCRAT3B
Fits 290mm tri	LYCRAT1WT	LYCRAT2WT	LYCRAT3WT	LYCRAT1BT	LYCRAT2BT	LYCRAT3BT
Length:	1m / 3.3ft	2m / 6.6ft	3m / 9.8ft	1m / 3.3ft	2m / 6.6ft	3m / 9.8ft
Colour:	White	White	White	Black	Black	Black
Zips (pairs)	1	3	4	1	3	4
Coating:	Fire retardant coating (ammonium polyphosphate)					

Fits 400mm box	LYCRAT41W	LYCRAT42W	LYCRAT43W	LYCRAT41B	LYCRAT42B	LYCRAT43B
Fits 400mm tri	LYCRAT41WT	LYCRAT42WT	LYCRAT43WT	LYCRAT41BT	LYCRAT42BT	LYCRAT43BT
Length:	1m / 3.3ft	2m / 6.6ft	3m / 9.8ft	1m / 3.3ft	2m / 6.6ft	3m / 9.8ft
Colour:	White	White	White	Black	Black	Black
Zips (pairs)	1	3	4	1	3	4
Coating:	Fire retardant coating (ammonium polyphosphate)					

Fits 220mm	LYCRAT21W	LYCRAT22W	LYCRAT23W	LYCRAT21B	LYCRAT22B	LYCRAT23B
Length:	1m / 3.3ft	2m / 6.6ft	3m / 9.8ft	1m / 3.3ft	2m / 6.6ft	3m / 9.8ft
Colour:	White	White	White	Black	Black	Black
Zips (pairs)	1	3	4	1	3	4
Coating:	Fire retardant coating (ammonium polyphosphate)					



T1200C*

SPIGOT BOX TRUSS TOP CIRCLE, 1200MM DIAMETER

	T1200C	T1200C2	T1200CBK	T1200C2BK
Truss size:	290mm / 11.4"	400mm / 15.7"	290mm / 11.4"	400mm / 15.7"
Diameter:	1200mm / 47.2"		1200mm / 47.2"	
Colour:	Washed		Black	

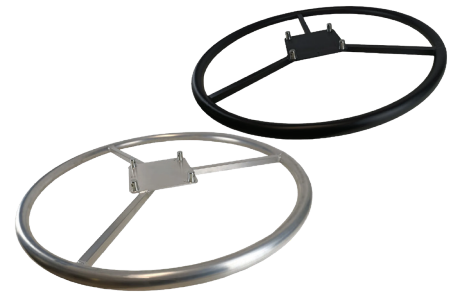

SPIGOTS, COUPLERS, CLIPS, PINS

	TC1	TC1B8	TC1B10	TC1B12	TC1C	TC2	TLCIP / BK	THINGE/ BK	TPIN / BK
Fits:					50mm tube				
Type:	Single Coupler M10 bolt, no location pin	Single Coupler M8 bolt, location pin	Single Coupler M10 bolt, location pin	Single Coupler M12 bolt, location pin	Single Coupler M10 bolt, location pin	Coupler Double coupler	Clip Clip for couplers	Coupler Hinged double coupler	Pin Pin for clips
Colour:	Washed	Washed	Washed	Washed	Washed	Washed	Washed / Black	Washed / Black	Washed / Black

	T30C1	T30C1B8	T30C1B10	T30C1B12	T30C1C	T30C2	T30LCIP / BK	T30HINGE/ BK	T30PIN / BKK
Fits:					30mm tube				
Type:	Single Coupler M10 bolt, no location pin	Single Coupler M8 bolt, location pin	Single Coupler M10 bolt, location pin	Single Coupler M12 bolt, location pin	Single Coupler M10 bolt, location pin	Double Coupler	Clip Clip for couplers	Coupler Hinged double coupler	Pin Pin for clips
Colour:	Washed	Washed	Washed	Washed	Washed	Washed	Washed / Black	Washed / Black	Washed / Black

	T60C1	T60C1B8	T60C1B10	T60C1B12	T60C1C	T60C2	T60LCIP / BK	T60HINGE/ BK	T60PIN / BK
Fits:					60mm tube				
Type:	Single Coupler M10 bolt, no location pin	Single Coupler M8 bolt, location pin	Single Coupler M10 bolt, location pin	Single Coupler M12 bolt, location pin	Single Coupler M10 bolt, location pin	Double Coupler	Clip Clip for couplers	Coupler Hinged double coupler	Pin Pin for clips
Colour:	Washed	Washed	Washed	Washed	Washed	Washed	Washed / Black	Washed / Black	Washed / Black

TRUSS TOWER LIFTS

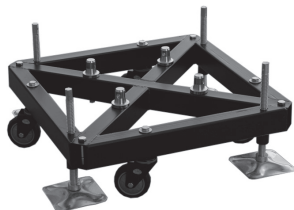

	3BG5	4BSG
Truss type:	290mm / 11.4" box	400mm / 15.7" box
Type:	Ground support	



	3BSB	3BSBBK	4BSB	4BSBBK	3BSB4	3BSB4BK	3BSB46	3BSB46BK	3BSB4WP	3BSB4WPBK
Truss type:	290mm / 11.4" box	400mm / 15.7" box	290 - 400mm / 11.4 - 15.7" box	290 - 400mm / 11.4 - 15.7" box	400 - 400x600mm / 15.7 - 15.7x23.6" box	290 - 400mm / 11.4 - 15.7" box	290 - 400mm / 11.4 - 15.7" box	290 - 400mm / 11.4 - 15.7" box	290 - 400mm / 11.4 - 15.7" box	290 - 400mm / 11.4 - 15.7" box
Type:	Sleeve block		Sleeve block		Sleeve block		Sleeve block		Sleeve block (whole piece with holes)	
Finishing:	Washed	Black	Washed	Black	Washed	Black	Washed	Black	Washed	Black



	3BGSS	4BGSS	3BOR	3BORBK
Truss type:	290mm / 11.4" box	400mm / 15.7" box	290mm / 11.4" box	
Type:		Sub support	Outrigger	
Finishing:		Washed	Washed	Black



	3BB	3BBBK	4BB	4BBBK	3BTBR
Truss type:	290mm / 11.4" box	400mm / 15.7" box	400mm / 15.7" box		290mm / 11.4" box
Type:	Dead weight dumper				Mount plate for winch
Finishing:	Washed	Black	Washed	Black	

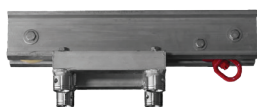

	3BTS	3BTSBK	4BTS	4BTSBK	3BTSL	3BTSLBK	4BTSL	4BTSLBK
Truss type:	290mm / 11.4" box	400mm / 15.7" box	400mm / 15.7" box		290mm / 11.4" box		400mm / 15.7" box	
Type:	Top msection				Line Array top msection			
Finishing:	Washed	Black	Washed	Black	Washed	Black	Washed	Black

LINE ARRAY TRUSS SYSTEM

LINE ARRAY STAND SYSTEM. 6M / 19.7FT HIGH

3BTLAC7PACK	
Height	6m / 19.7ft
Load Capacity:	480 kg / 1058 lbs
Truss type:	290mm / 11.4"
Coating:	Washed or Black

LINE ARRAY TRUSS SYSTEM INCLUDES:

1 x 3BTSL	290mm / 11.4" Box Truss Line Array Top section
1 x T3BD1.5R2	Curved 290mm / 11.4" Box Truss - 2m / 6.6ft
1 x 3BTROLL	Wheels connection part
1 x 3BTLABASE	Black base
1 x T3BD05	290mm / 11.4" box truss - 0.5m / 1.6ft
2 x T3BD2	290mm / 11.4" box truss - 2m / 6.6ft
1 x 3BTBR	Horizontal truss mount plate for winch
12 x TC2	Trussing Double Coupler / Spigot
36 x TCLIP	Trussing Clip
36 x TPIN	Trussing Pin
2 x THINGE	Trussing Coupler / Spigot Hinge
4 x 3BOR	Box Truss Ground Support Outrigger

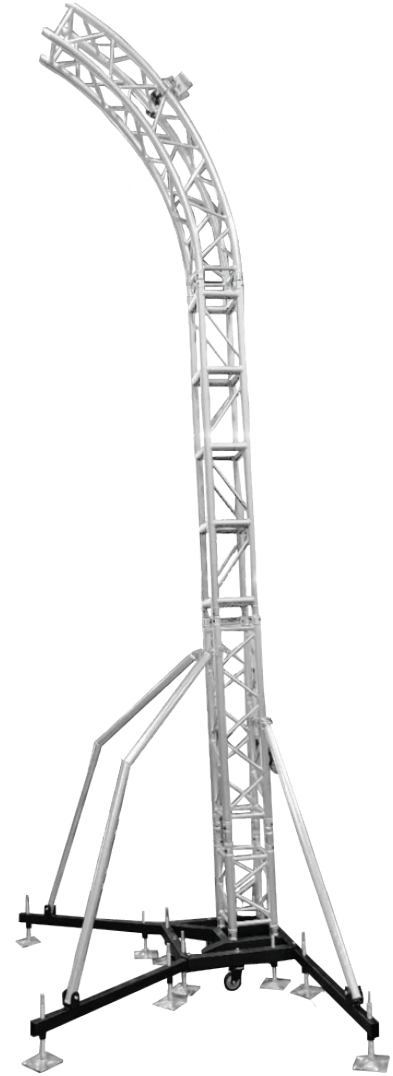

SPEAKER TRUSS SYSTEM

290 x 290 MM / 11.4 X 11.4" TRUSS. HEIGHT 6M / 19.7FT

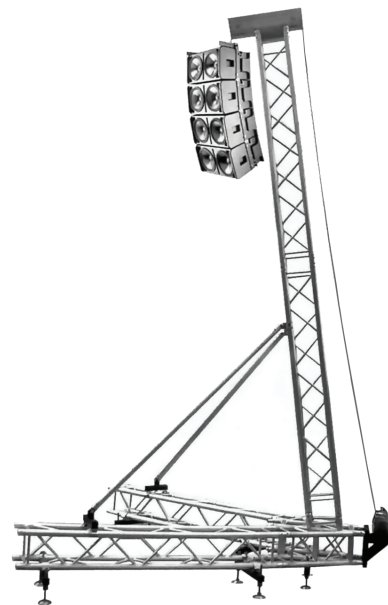

3BTLAC6PACK / 3BTLAC6PACKBK	
Height	6m / 19.7ft
Load Capacity:	500 kg - 600 kg / 1102 - 1323 lbs
Truss type:	290mm / 11.4"
Coating:	Washed or Black

CUSTOM TRUSS

TRUSS STRUCTURES

Truss structures using a combination of truss raising stands, truss lengths and junctions can be designed and produced to suit the requirements of any event. From basic arches, to large concert sized structures, our team can produce a tailor made solution for any situation. Here are some examples.

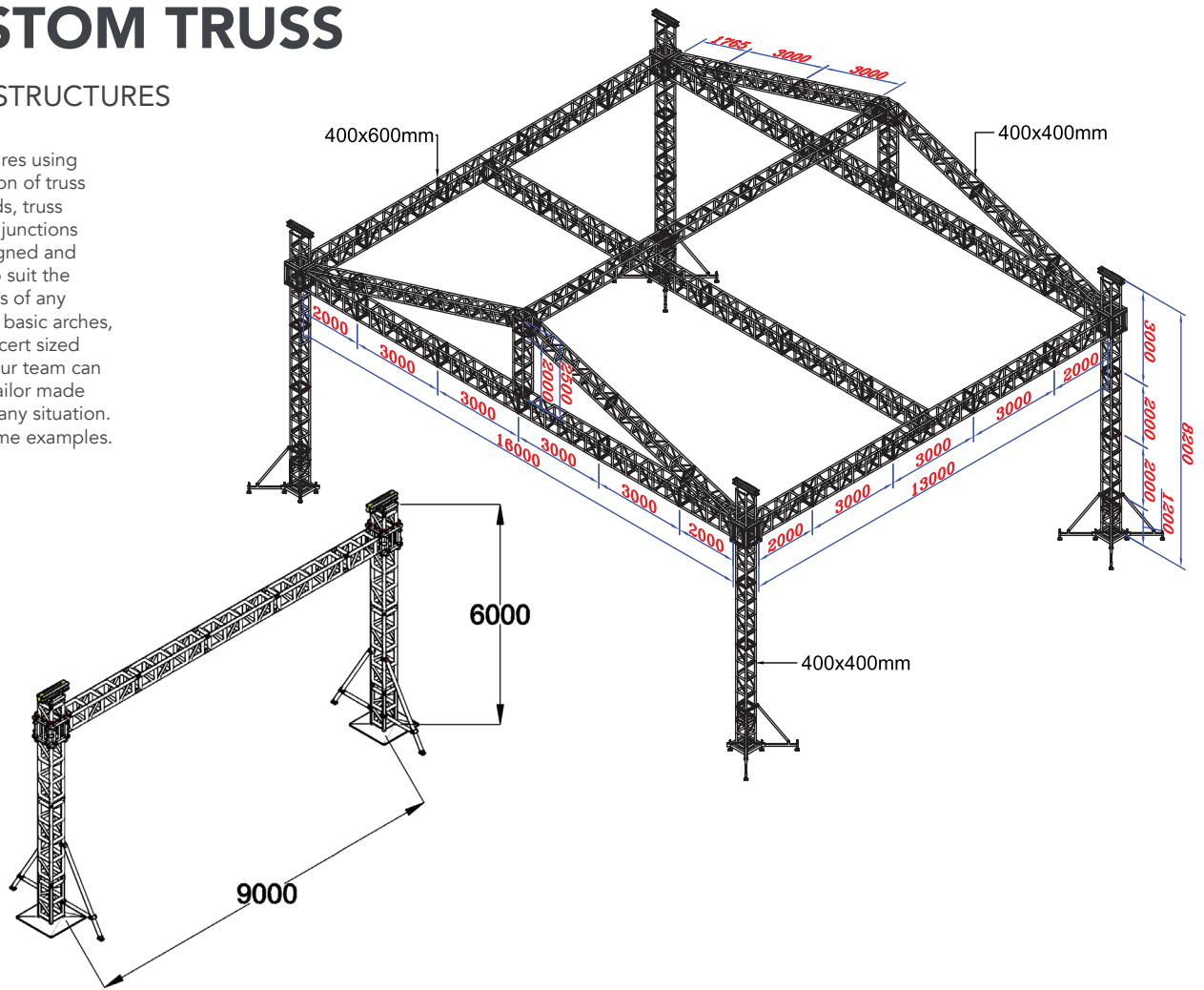

IRREGULAR TRUSSING

Any shape, any configuration, any design you can dream of - it is all possible. Our team of engineers can design truss in any shape, using any dimensions you use, while our manufacturing team will produce the product to our high standards. Whether it be circular, triangular, star-shape, or three dimensional - you name it, we can produce it.

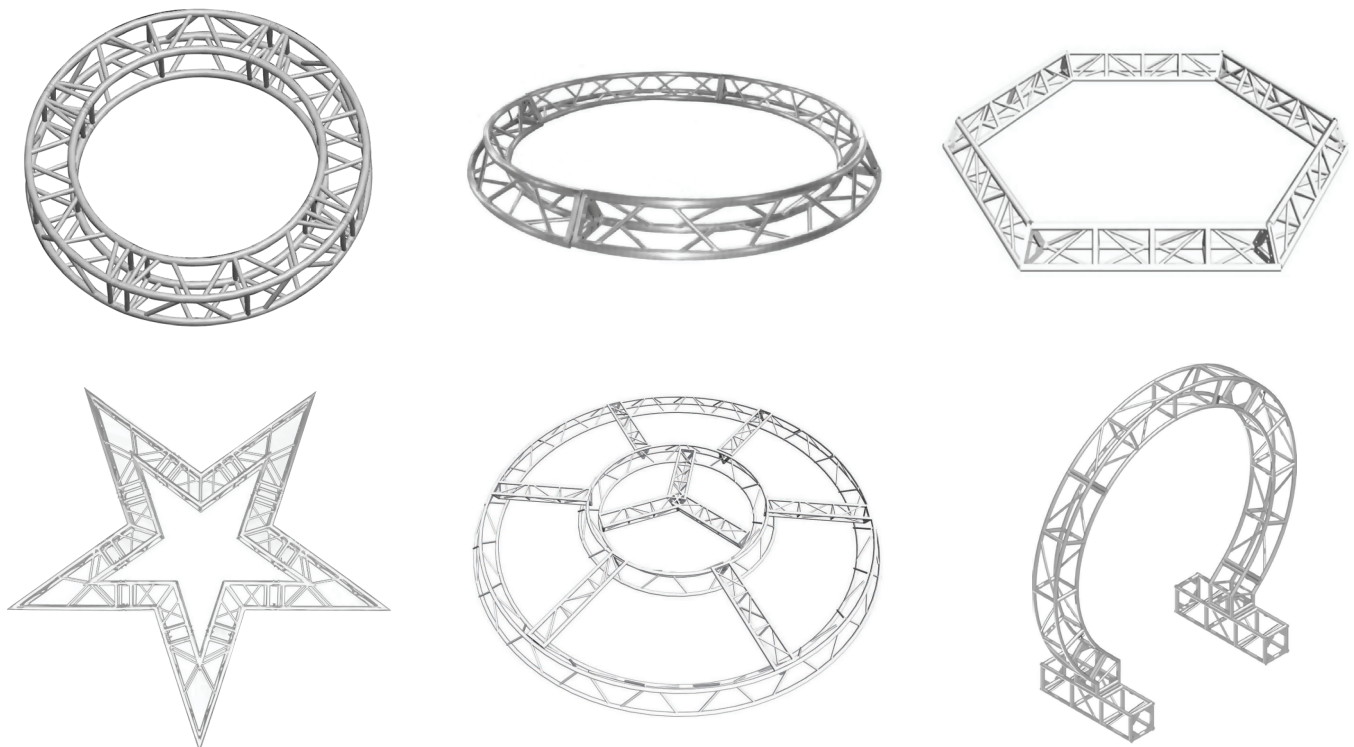

CROWD BARRIERS

Crowd barriers are necessary for the protection and security of stages. Our crowd barriers are stable and pressure resistant ensuring maximum protection for entertainers and audiences. They are easy to construct offering quick setup and pack-down into a transport efficient format.



	CB1GMK2	CB1GMK2BK
Type:	Crowd barrier with gate	
Width (m / ft):	1 / 3.3	
Folded for transport at (m / ft):	1 x 1.25 x 0.15 / 3.3 x 4.1 x 0.5	
Standard size (m / ft):	1 x 1 x 1.25 / 3.3 x 3.3 x 4.1	
Free standing:	Yes	
Material:	Aluminium	
Finishing:	Washed	Black

	CB1MK2	CB1MK2BK
Type:	Crowd barrier	
Width (m / ft):	1 / 3.3	
Folded for transport at (m / ft):	1 x 1.25 x 0.15 / 3.3 x 4.1 x 0.5	
Standard size (m / ft):	1 x 1 x 1.25 / 3.3 x 3.3 x 4.1	
Free standing:	Yes	
Material:	Aluminium	
Finishing:	Washed	Black



	CB1GMK2	CB1GMK2BK
Type:	Crowd barrier 90 degree corner	
Width (m / ft):	1	
Folded for transport at (m / ft):	1 x 1.25 x 0.15 / 3.3 x 4.1 x 0.5	
Standard size (m / ft):	1 x 1 x 1.25 / 3.3 x 3.3 x 4.1	
Free standing:	Yes	
Material:	Aluminium	
Finishing:	Washed	Black

	CB1PMK2	CB1PMK2BK
Type:	Crowd barrier pass through model	
Width (m / ft):	1	
Folded for transport at (m / ft):	1 x 1.25 x 0.15 / 3.3 x 4.1 x 0.5	
Standard size (m / ft):	1 x 1 x 1.25 / 3.3 x 3.3 x 4.1	
Free standing:	Yes	
Material:	Aluminium	
Finishing:	Washed	Black



	CBTROLLEYA
Type:	Heavy duty foldable stackable crowd barrier trolley
Holds up:	10 pieces CB1MK2 Crowd Barrier
Standard size (m / ft):	1.37 x 1.05 x 1.63 / 4.5 x 3.4 x 5.3
Castors included:	Yes
Material:	Aluminium
Finishing:	Washed

	CB1WEDGE / CB1WEDGEBK
Type:	Wedge for CB1MK2 Crowd Barrier
Material:	Aluminium
Finishing:	Washed / Black

STAGE TOPS

STAGE TOP WITH RAIL LOCK SYSTEM



STANDARD LATCH

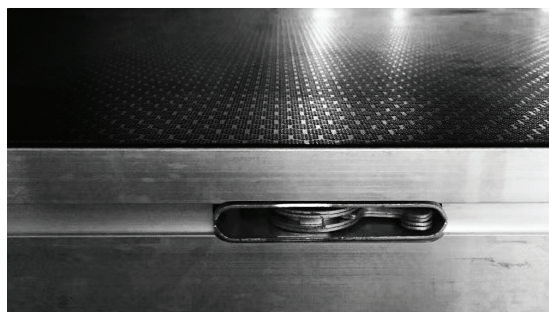

COFFIN LATCH

	ST1010 / STC1010	ST1203	ST1206 / STC1206	ST1209	ST1212 / STC1212	ST1212ARC
Type:	Stage top	Stage top	Stage top	Stage top	Stage top	Quarter Curve Stage top
Latch type:	Standard / Coffin	Standard	Standard / Coffin	Standard	Standard / Coffin	Standard
Size (mm / inch):	1000 x 1000 / 39.4 x 39.4	1220 x 305 / 48.0 x 12.0	1220 x 610 / 48.0 x 24.0	1220 x 915 / 48.0 x 36.0	1220 x 1220 / 48.0 x 48.0	1220 x 1220 / 48.0 x 48.0
Weight (kg / lbs):	15 / 33.1	10.9 / 24.0	17 / 37.5	24 / 52.9	27 / 59.5	20 / 44.1
Average load (kg / lbs):	650 / 1433	500 / 1102	850 / 1874	725 / 1598	950 / 2094	1750 / 3858
Centre point load (kg / lbs):	325 / 717	350 / 772	550 / 1213	360 / 794	500 / 1102	750 / 1653
Material:	18mm Plywood and Aluminium					
Pattern:	Anti Skid Black Hex					

	ST1806 / STC1806	ST1812 / STC1812	ST2010 / STC2010	ST2406 / STC2406	ST2410	ST2412 / STC2412
Type:	Stage top	Stage top	Stage top	Stage top	Stage top	Stage top
Latch type:	Standard / Coffin	Standard / Coffin	Standard / Coffin	Standard / Coffin	Standard	Standard / Coffin
Size (mm / inch):	1830 x 610 / 72.0 x 24.0	1800 x 1200 / 70.9 x 48.0	2000 x 1000 / 78.7 x 39.4	2440 x 610 / 96.1 x 24.0	2400 x 1000 / 94.5 x 39.4	2440 x 1220 / 96.1 x 48.0
Weight (kg / lbs):	21 / 46.3	25 / 55.1	30 / 66.1	36 / 79.4	42 / 92.6	45 / 99.2
Average load (kg / lbs):	1130 / 2491	1450 / 3197	1300 / 2866	1110 / 2425	1560 / 3439	1750 / 3858
Centre point load (kg / lbs):	500 / 1102	725 / 1598	650 / 1433	500 / 1102	780 / 1720	750 / 1653
Material:	18mm / 07" Plywood and Aluminium					
Pattern:	Anti Skid Black Hex					

STAGE LEGS / CASTORS

50M STAGE LEGS / ADJUSTABLE STAGE LEGS



	SL02	SL03	SL06	SL09	SL12
Type:	Stage leg				
Length (mm / inch):	195 - 225 / 7.7 - 8.9	295 - 325 / 11.6 x 12.8	595 - 625 / 23.4 - 24.6	895 - 925 / 35.2 x 36.4	1195 - 1225 / 47 x 48.2
Weight (kg / lbs):	1 / 2.2	1.1 / 2.4	1.4 / 3.1	1.5 / 3.3	1.6 / 3.5
Main tube diameter:	50mm / 2"				
Foot diameter:	70mm / 2.8"				

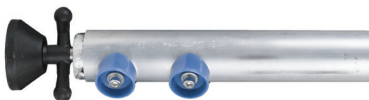

	SL0406	SL0610	SL1015
Type:	Adjustable Stage Legs		
Length (mm / inch):	320 - 490 / 12.6 - 19.3	520 - 890 / 20.5 - 35.0	1000 - 1500 / 39.4 - 59.1
Weight (kg / lbs):	1.2 / 2.6	1.5 / 3.3	1.55 / 3.4
Main tube diameter:	50mm / 2"		
Foot diameter:	70mm / 2.8"		

STAGE CASTORS



	SLCL	SLC
Type:	Stage top	Stage leg castor
Lock:	Yes	No
Tread:	M16	M16
Weight (kg / lbs):	1 / 2.2	1 / 2.2

STAGE ACCESSORIES

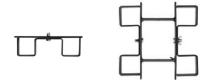

	SKIRT300 / SKIRT300W	SKIRT600 / SKIRT600W	SKIRT900 / SKIRT900W	SKIRT1200 / SKIRT1200W
Type:	Skirt for stage top			
Length:	2440mm / 96.1"			
Height:	300mm / 11.8"	600mm / 23.6"	900mm / 35.4"	1200mm / 47.2"
Weight:	1 kg / 2.2 lbs	1.4 kg / 3.1 lbs	2.5 kg / 5.5 lbs	2.9 kg / 4.4 lbs
Material:	100% Polyester with flame retardant coating and velcro			

LEG CLAMP	SL2C	SL4C
Type:	Two Way	Four Way
Weight:	2 kg / 4.4 lbs	3 kg / 6.6 lbs
Finishing:	Black	
Material:	Steel	

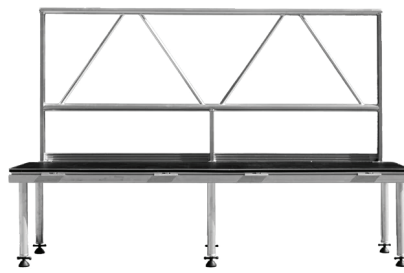

Stage Clamp allows connecting different types of stage tops

	SR10	SR12	SR20	SR24
Type:	Stage Guard Rail			
Width:	1000mm / 39.4"	1220mm / 48.0"	2000mm / 78.7"	2440mm / 96.1"
Weight:	5 kg / 11 lbs	5.2 kg / 11.5 lbs	16 kg / 35.3 lbs	20 kg / 44.1 lbs
Finishing:	Washed			
Material:	Aluminium 6061-T6			

	SRC
Type:	Stage Clamp
Finishing:	Black
Material:	Steel
Weight:	0.3 kg / 0.7 lbs



	SSTAIRS3	SSTAIRS4	SSTAIRS5
Type:	Stage stair steps package		
Includes:	SSSTEP x 2 ST1203 x 1 SS3 (pair of step support rail) x 1 Stage legs x 4 SL2C (two-way leg clamp) x 2	SSSTEP x 3 ST1203 x 1 SS4 (pair of step support rail) x 1 SS4R (one side hand rail) Stage legs x 4 SL2C (two-way leg clamp) x 2	SSSTEP x 4 ST1203 x 1 SS5 (pair of step support rail) x 1 SS5R (one side hand rail) Stage legs x 4 SL2C (two way leg clamp) x 2

	SSSTEP
Type:	Stair step
Size:	1200 x 300mm / 47.2 x 11.8"
Weight:	8.7 kg / 19.2 lbs
Material:	Plywood and Aluminium



	SS3R	SS4R	SS5R	SS8R
Type:	Stage Stairs Hand Rails			
Steps:	3	4	5	8
Weight (kg / lbs):	5 / 11	6.2 / 13.7	10 / 22	12 / 26.5
Material:	Aluminium			



	SS2	SS3	SS4	SS5	SS8
Type:	Stage rails (pair)				
Steps:	2	3	4	5	8
length (mm / inch):	200 to 600 / 7.9 to 23.6	500 to 800 / 19.7 to 31.5	600 to 1000 / 23.6 to 39.4	800 to 1200 / 31.5 to 47.2	1000 to 1500 / 39.4 to 59.1
Size (mm / inches):	1830 x 610 / 72.0 x 24.0	1800 x 1200 / 70.9 x 47.2	2000 x 1000 / 78.7 x 39.4	2440 x 610 / 96.1 x 24.0	2400 x 1000 / 94.5 x 39.4
Weight (kg / lbs):	6.2 / 13.7	8.4 / 18.5	10 / 22	11 / 24.3	12 / 26.5
Material:	Aluminium				



BRACED STAGING SYSTEM

QUICK SET UP, VERY STABLE USING LEGS AND BRACES



	STB1010	STB2010	STB1212	STB2412
Type:	Stage top			
Size (mm):	1000 x 1000	2000x1000	1220 x 1220	2400x1220
Size (inch):	39.4 x 39.4	78.7 x 39.4	48.0 x 48.0	94.5 x 48.0
Weight (kg / lbs):	20 / 44.1	70 / 154.3	44 / 97	100 / 220.5
Max. load (kg/m2)	1100			
Material:	18mm / 0.7" waterproof plywood			
Pattern:	Anti Skid Black Hex			
Certification:	TUV			

STB1010T	
Type:	Transparent stage top
Size (mm / inch):	1000 x 1000 / 39.4 x 39.4
Weight (kg / lbs):	20 / 44.1
Max. load (kg/m2)	750
Material:	Acrylic
Pattern:	Anti Skid Transparent
Certification:	TUV

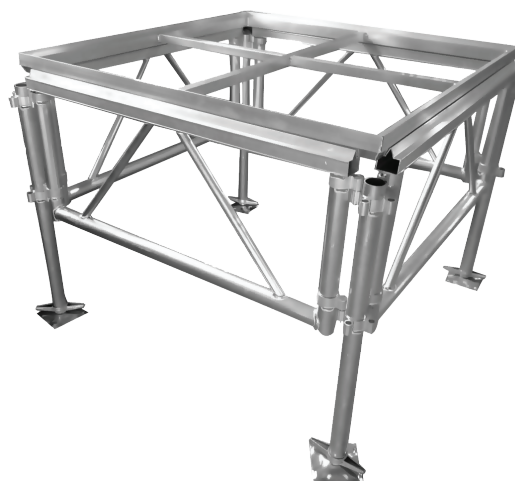

	SLB06	SLB09	SLB12
Type:	Stage leg for brace truss		
Length (mm / inch):	600 / 23.6	900 / 35.4	1200 / 47.2
Weight (kg / lbs):	2 / 4.4	2.1 / 4.6	2.3 / 5.1

	SLB0406	SLB0610	SLB1015
Type:	Stage leg for brace truss adjustable		
Length (mm):	400 - 600	600 - 1000	1000 - 1500
Length (inch):	15.7 - 23.6	23.6 - 39.4	39.4 - 59.1
Weight (kg / lbs):	5 / 11	6.5 / 13.2	8 / 17.6

	SBB10	SBB20	SBB12	SBB24
Type:	Brace			
Length (mm / inch):	1000 / 39.4	2000 / 78.7	1220 / 48.0	2440 / 96.0
Weight (kg / lbs):	5 / 11	10 / 22	6 / 13.2	12.5 / 27.6

BRACED STAGING STEPS



	SSB2	SSB3	SSB4	SSB5	SSB8
Type:	Step rails				
Length (mm / inch):	400 / 15.7	600 / 23.6	800 / 31.5	900-1000 / 35.4 - 39.4	1500 / 59.1
Weight (kg / lbs):	10 / 22	11 / 24.3	12 / 26.5	13 / 28.7	15 / 33.1
Number of steps:	2	3	4	5	8

	SRB10	SRB20	SRB12	SRB24
Type:	Stage rail			
Length (mm / inch):	1000 / 39.4	2000 / 78.7	1220 / 48.0	2440 / 96.0
Weight (kg / lbs):	13 / 28.7	26 / 57.3	15 / 33.1	30 / 66.1

SSBSTEP	
Type:	Stair step to suit SSB 2 / 3 / 4 / 5 / 8
Material:	Plywood and Aluminium

	SSB4R	SSB5R	SSB8R
Type:	Hand rails		
Length (mm / inch):	400 / 15.7	600 / 23.6	800 / 31.5
Weight (kg / lbs):	11 / 24.3	12 / 26.5	13 / 28.7
Number of steps:	2	3	4

FOLDING LEG STAGING

FOLDING LEGS EASY TO ERRECT, TAKE LESS SPACE, QUICK SET UP



	STF1010	STF2010
Type:	Folding leg stage top	
Size (mm / inch):	1000 x 1000 / 39.4 x 39.4	2000 x 1000 / 78.7 x 78.7
Weight (kg / lbs):	10 / 22	20 / 44.1
Max. load (kg/m2)	750	
Material:	12mm / 0.5" non-slip wood	
Frame:	Aluminum	
Certification:	TUV	

	STF0410
Type:	Step top
Size (mm / inch):	1000 x 400 / 39.4 x 15.7
Weight (kg / lbs):	4.6 / 10.1
Max. load (kg/m2)	750
Material:	12mm / 0.5" non-slip wood
Frame:	Aluminum
Certification:	TUV

	SLF04	SLF042	SLF06	SLF062	SLF10	SLF102
Type:	Folding legs for stage top					
Legs height (mm / inch):	400 / 15.7	400 / 15.7	600 / 23.6	600 / 23.6	1000 / 39.4	1000 / 39.4
Weight (kg / lbs):	0.15 / 0.33	0.3 / 0.66	0.2 / 0.4	0.4 / 0.88	0.3 / 0.66	0.6 / 1.32
Suits stage top (mm):	1000 x 1000	2000 x 1000	1000 x 1000	2000 x 1000	1000 x 1000	2000 x 1000
Suits stage top (inch):	39.4 x 39.4	78.7 x 39.4	39.4 x 39.4	78.7 x 39.4	39.4 x 39.4	78.7 x 39.4



STEPS

	STF1040
Type:	Step top for folding leg stage
Size:	1000 x 400mm / 39.4 x 15.7"
Weight (kg / lbs):	10 / 22

	SLFS200	SLFS250	SLFS400	SLFS500	SLFS750
Type:	Folding legs for steps				
Length (mm / inch):	200 / 7.9	250 / 9.8	400 / 15.7	500 / 19.7	750 / 29.5
Weight (kg / lbs):	0.2 / 0.44	0.25 / 0.55	0.4 / 0.88	0.45 / 0.99	0.5 / 1.1

	SLFCLIP
Type:	Clip for securing stage legs
Weight (kg / lbs):	0.2 / 0.44



CLAMPS

HOOK / PIPE / TRIGGER CLAMPS

Necessary for every job, Event Lighting clamps are produced from high quality aluminium and are TUV certified. Our range includes many options as well as safety chains and boom arms.



CLAMPG50/50S/50L/50LS

Type:	Hook Clamp
Pipe size:	35-51mm / 1.2- 2.0" tube
Width:	25mm / 2"
WLL:	50/150/75/75 kg / 110/331/165/156 lbs
Bolt:	M10x30
Material:	Steel
Certification:	TUV

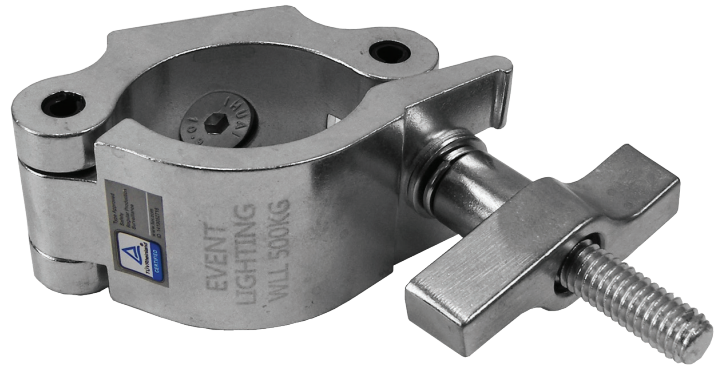

CLAMPP50W/CLAMPP50WS

Type:	Pipe Clamp
Pipe size:	35-51mm / 1.2- 2.0" tube
Width:	50mm / 2"
WLL:	500 kg / 1102 lbs
Bolt:	M10x30
Material:	Aluminium 6061-T6
Certification:	TUV



CLAMPP50/CLAMPP50S

Type:	Pipe Clamp
Pipe size:	35-51mm / 1.2- 2.0" tube
Width:	30mm / 1.2"
WLL:	300 kg / 661 lbs
Bolt:	M10x30
Material:	Aluminium 6061-T6
Certification:	TUV



CLAMPP50L/CLAMPP50LS

Type:	Pipe Clamp
Pipe size:	46-51mm / 1.8- 2.0" tube
Width:	30mm / 1.2"
WLL:	75 kg / 165 lbs
Bolt:	M10x30
Material:	Aluminium 6061-T6
Certification:	TUV

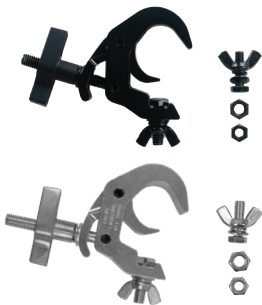

CLAMPT50/50S/50L/50LS

Type:	Trigger Clamp
Pipe size:	38-51mm / 1.5-2.0" tube
Width:	30mm / 1.2"
WLL:	50/150/75/75 kg / 110/331/165/156 lbs
Bolt:	M12x30 and M10x30
Material:	Aluminium 6061-T6
Certification:	TUV



CLAMPTG50/CLAMPTG50S

Type:	Trigger G Clamp
Pipe size:	48-51mm / 1.9-2.0" tube
Width:	28mm / 1.1"
WLL:	150 kg / 331 lbs
Bolt:	M10x30
Material:	Aluminium 6061-T6
Certification:	TUV



CLAMPTQ50/CLAMPTQ50S

Type:	Trigger Clamp
Pipe size:	48-51mm / 1.9-2.0" tube
Width:	28mm / 1.1"
WLL:	150 kg / 331 lbs
Bolt:	M10x30
Material:	Aluminium 6061-T6
Certification:	TUV

CLAMPS

PIPE CLAMPS AND PACKAGES



PIPE CLAMP AND COUPLER

PACKAGE INCLUDES:

1x CLAMPP	Pipe Clamp
1x TC1	Trussing Coupler
1x TPIN	Trussing Pin
1x TCLIP	Trussing Clip

PIPE CLAMP AND EYENUT

PACKAGE INCLUDES:

1x CLAMPP	Pipe Clamp
1x CLAMPPEYENUT	Eye nut

CLAMPP60 / CLAMPP60S

Type:	Pipe Clamp
Pipe size:	58-61mm / 2.3-2.4" tube
Width:	30mm / 1.2"
WLL:	500 kg / 1102 lbs
Bolt:	M10x30
Material:	Aluminium 6061-T6
Certification:	TUV

CLAMPP38LB/CLAMPP38LS

Type:	Pipe Clamp
Pipe size:	35-40mm / 1.4-1.6"
Width:	30mm / 1.2"
WLL:	75 kg / 165 lbs
Bolt:	M10x30
Material:	Aluminium 6061-T6
Certification:	TUV

CLAMPP30LB/CLAMPP30LS

Type:	Pipe Clamp
Pipe size:	30-35mm / 1.2-1.4" tube
Width:	30mm / 1.2"
WLL:	100 kg / 220 lbs
Bolt:	M8x30
Material:	Aluminium 6061-T6
Certification:	TUV

CLAMPP25LB/CLAMPP25LS

Type:	Pipe Clamp
Pipe size:	23-27mm / 0.9-1.1" tube
Width:	25mm / 1.0"
WLL:	60 kg / 132 lbs
Bolt:	M8x30
Material:	Aluminium 6061-T6
Certification:	TUV

CLAMPP20LB/CLAMPP20LS

Type:	Trigger Clamp
Pipe size:	19-23mm / 0.7-0.9" tube
Width:	25mm / 1.0"
WLL:	60 kg / 132 lbs
Bolt:	M18x30
Material:	Aluminium 6061-T6
Certification:	TUV

CLAMPS

DOUBLE SWIVEL PIPE CLAMPS



CLAMPDPW50/CLAMPDPW50S

Type:	Double Swivel Pipe Clamp
Pipe size:	38-51mm / 1.5-2.0" tube
Width:	50mm / 2.0"
WLL:	500 kg / 1102 lbs
Lockable:	at 90°/180°
Material:	Aluminium 6061-T6
Certification:	TUV



CLAMPDP50/CLAMPDP50S

Type:	Double Swivel Pipe Clamp
Pipe size:	38-51mm / 1.5-2.0" tube
Width:	30mm / 1.2"
WLL:	300 /75 kg 661/165 lbs
Lockable:	at 90°/180°
Material:	Aluminium 6061-T6
Certification:	TUV



CLAMPDP50L/CLAMPDP50LS

Type:	Double Swivel Pipe Clamp
Pipe size:	38-51mm / 1.5-2.0" tube
Width:	30mm / 1.2"
WLL:	75 kg / 165 lbs
Lockable:	-
Material:	Aluminium 6061-T6
Certification:	TUV



CLAMPDP38B/CLAMPDP38S

Type:	Double Swivel Pipe Clamp
Pipe size:	35-40mm / 1.4-1.6"
Width:	30mm / 1.2"
WLL:	75 kg / 165 lbs
Lockable:	-
Material:	Aluminium 6061-T6
Certification:	TUV



CLAMPDP30B/CLAMPDP30S

Type:	Double Swivel Pipe Clamp
Pipe size:	30-35mm / 1.2-1.4" tube
Width:	30mm / 1.2"
WLL:	100 kg / 220 lbs
Lockable:	-
Material:	Aluminium 6061-T6
Certification:	TUV



CLAMPDP25B/CLAMPDP25S

Type:	Double Swivel Pipe Clamp
Pipe size:	23-27mm / 0.9-1.1" tube
Width:	25mm / 1.0"
WLL:	60 kg / 132 lbs
Lockable:	-
Material:	Aluminium 6061-T6
Certification:	TUV



CLAMPP20LB/CLAMPP20LS

Type:	Double Swivel Pipe Clamp
Pipe size:	19-23mm / 0.7-0.9" tube
Width:	25mm / 1.0"
WLL:	60 kg / 132 lbs
Lockable:	-
Material:	Aluminium 6061-T6
Certification:	TUV



CLAMPDP50S locked at 90°

UNIVERSAL CLAMPS



CLAMPB160 / CLAMPB160S	
Type:	Universal Hocker/Marquee Beam Clamp
Fits Beam Width:	40-130mm / 1.6-5.1"
Threaded Hole Size:	2x M10, 2x M12, 1x M14
WLL	100 kg / 220 lbs
Material:	Steel



CLAMP50	
Type:	Universal (Any Shape) Beam Clamp
Fits:	Any shape, any tube up to 50mm
WLL	25 kg / 55 lbs
Certification:	TUV

MULTIPLE DIAMETER CLAMP

SUITS PIPES 25MM, 38MM AND 50MM

The CLAMPE38 is a light duty tube clamp for attaching your lighting fixtures to your stands and trussing. Designed with removable adapters allowing it to fit a variety of stand and trussing diameters: 25mm, 38mm and 50mm.



CLAMPE38	
Type:	Variable Diameter Clamp
Pipe size:	25, 38 or 50mm / 1.0, 1.5 or 2.0" tube
WLL:	25 kg / 55 lbs
Bolt:	M10
Material:	Plastic
Certification:	TUV

BOOMARMS

BOOM ARM WITH PIPE CLAMP, 3MM / 0.1" WALL THICKNESS



	BOOMARM105	BOOMARM105B	BOOMARM205	BOOMARM205B
Type:	Boom Arm with Single Pipe Clamp		Boom Arm with Double Pipe Clamp	
Pipe Length:			500mm / 19.7"	
Pipe Thickness:			3mm / 0.1"	
Pipe Clamp Fit:			38-51mm / 1.5-2.0" tube	
Pipe Clamp Width:			50mm / 2.0"	
WLL:	80 kg / 176 lbs		150 kg / 331 lbs	
Materials:			Aluminum alloy 6061-T6	
Finishing:	Washed	Black coated	Washed	Black coated

ACCESSORIES

TRUSS HANGERS, EYENUTS, SAFETY WIRES



	THANGER
Type:	Truss Hanger
WLL:	300 kg / 661 lbs
Fits:	Up to 520mm / 20.5" truss
Clamps:	2 x movable clamps
Material:	Aluminium 6061-T6
Certification:	TUV

	CLAMPPEYENUT	CLAMPPEYENUTS
Type:	Eye Nut and Bolt	
WLL:	230 kg / 507 lbs	
Bolt:	M10x20	
Material:	Aluminium 6061-T6	
Certification:	TUV	
Finishing:	Black coated	Washed



	SW3X800PC/PB	SW4X800PC/PB
Type:	Safety wire	
Length:	800mm / 31.5"	
Thickness:	3mm / 0.1"	4mm / 0.2"
WLL:	40 kg / 88 lbs	120 kg / 265 lbs
Dead weight break point:	230 kg / 507 lbs	320 kg / 705 lbs
Material:	PVC coated steel	
Certification:	TUV	
Finishing:	Washed / Black	Washed / Black

	SW4X800SS/SSB	SW5X1000PC/PB	SW4X800PCS/PBS
Type:	Safety wire outdoor	Safety wire	Safety wire with screw
Length:	800mm / 31.5"	1000mm / 39.4"	800mm / 31.5"
Thickness:	4mm / 0.2"	5mm / 0.2"	4mm / 0.2"
WLL:	120 kg / 265 lbs	150 kg / 331 lbs	120 kg / 265 lbs
Dead weight break point:	320 kg / 705 lbs	605 kg / 1334 lbs	320 kg / 705 lbs
Material:	PVC coated steel		
Certification:	TUV		
Finishing:	Washed / Black	Washed / Black	Washed / Black







INTRODUCING

AV REALM

Control for Any Ethernet-Controllable
Devices Including LED Screen, Home
Entertainment & Automation

Features

Easy To Use

- Add a Button
- Set the Command
- Control Your Device
- Device Presets to make Setup Easy

Make it Your Own

- Customisable Button Images
- Upload A Unique Background
- Set Any Command to any Button



● Universal Compatibility

Works with any TCP/UDP enabled device, giving you control over any device on your network.

● Customisable Buttons

Create buttons and map them to any function of your device and/or navigate to other pages within the app!

● Personalised Appearance

Import personalised Images to create your own unique look and feel. Represent your brand, business or use a meaningful photo.

ENGINEERING

Innovative Engineering for Complete Peace of Mind

Event Lighting boasts a team of highly qualified structural engineers located in both our Sydney and Guangzhou offices. This dedicated team offers unparalleled expertise in the design and development of custom trussing, structures, and staging for live events, installations, educational institutions and anywhere trussing or staging is utilised.

Our engineers provide comprehensive support, including:

- **Custom Design:** Event Lighting's engineers collaborate with clients to develop tailor-made trussing, structures, and staging solutions that perfectly match the clients' specific requirements.
- **Structural Analysis:** Our engineers meticulously verify structural loadings to ensure the safety and integrity of all our products.
- **Loading Table Accuracy:** We guarantee the accuracy of loading tables for all our products, ensuring compliance with applicable safety standards and regulations.
- **Unwavering Safety Commitment:** Event Lighting prioritises safety and compliance. Our rigorous engineering ensures zero risk when our products are used correctly.

Event Lighting's team of expert engineers ensures every customer receives the service, care and reliability that Event Lighting is known for.

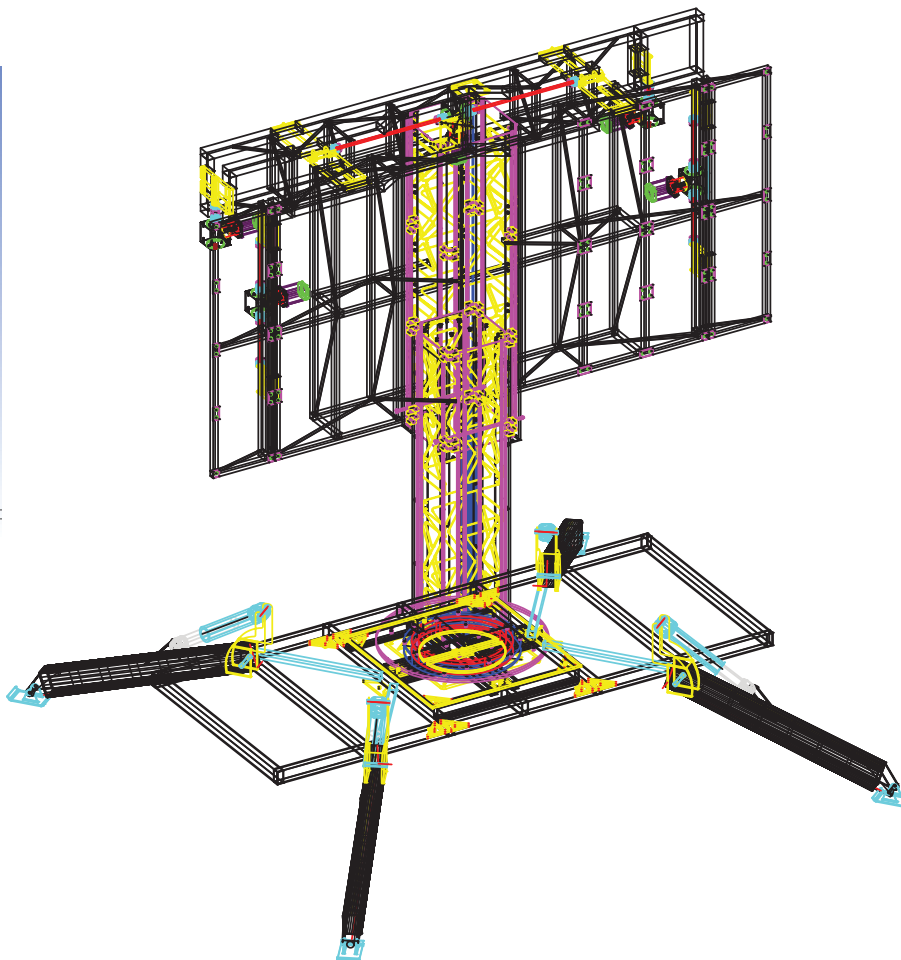
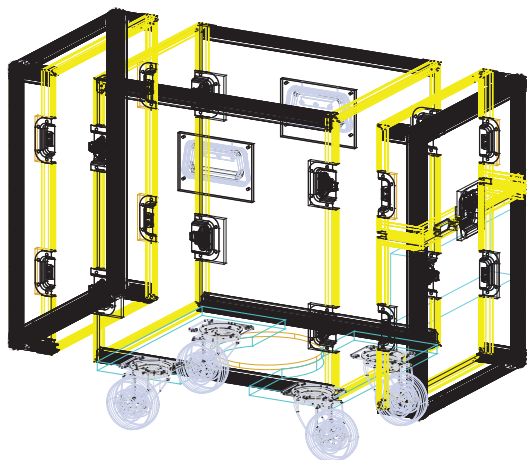
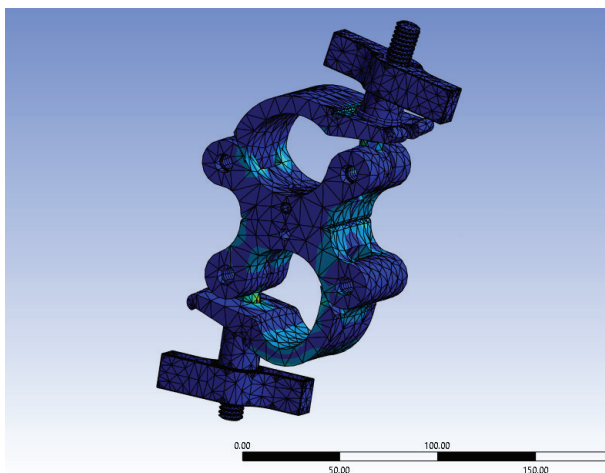

Event Lighting is proud to have partnered with Guangzhou Aoka Stage Equipments Co., Ltd for manufacturing and supplying all of its entertainment trussing, staging, and related structural products. Established in 2010, Aoka and Event Lighting have been manufacturing quality products for many years.

Aoka specialises in design, product research, product development and production. Products include aluminium entertainment trussing with various designs and specifications, staging systems for the entertainment and education markets, and all associated accessories. Aoka prides itself on providing high quality products which meet all necessary international standards and certifications while also being able to design and produce custom products in accordance with customer requirements.

The factory's attention to detail, production and design skills have recently been applied to a new department producing road cases and flight cases for the entertainment market.

Aoka has enjoyed success in many international markets including the Middle East, Europe, Australia and of course in their home country of China.

The business is founded on the principles of always adhering to quality first, placing customer needs as their highest priority, and ensuring all products are manufactured to very high standards.

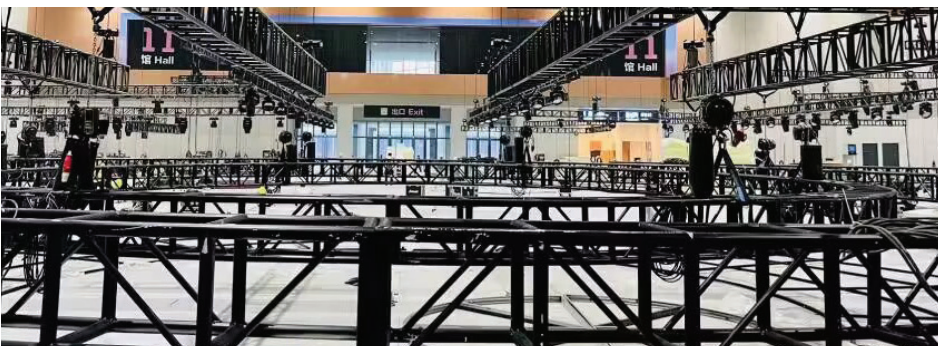

NOTES

A series of horizontal dotted lines for writing notes.

NOTES

A series of horizontal dotted lines for writing notes.



CATALOGUE 2025



International Sales

+61 450 745 600
sales@eventlighting.com.au
www.eventlighting.com.au
Sydney | Guangzhou

E&OE. Errors and omissions excepted. Specifications and features of products within this catalogue subject to change without notice.
Pictures may be representations of products and not an exact indication of the appearance of the final product.