



# NX Series Product User Manual

**NX1.5/NX1.8/NX2.5/NX3.7**



**Shenzhen Absen Optoelectronic Co.,Ltd.**

# CONTENT

<b>Safety Information.....</b>	<b>2</b>
<b>1 Product Introduction.....</b>	<b>5</b>
1.1 Product application scenarios.....	6
1.2 Main features.....	7
1.3 Product parameters.....	9
<b>2 Introduction of Product Components.....</b>	<b>11</b>
2.1 Product size introduction.....	11
2.2 Introduction of cabinet components.....	13
2.3 Introduction to Splicing Scheme.....	14
<b>3 Product Installation.....</b>	<b>17</b>
3.1 stacking installation.....	18
3.2 Hanging installation.....	22
3.3 Wall mounting.....	24
3.4 Trim pieces installation.....	27
<b>4 Product Wiring.....</b>	<b>29</b>
4.1 Preparation before connection.....	29
4.2 Power cable connection.....	29
4.3 Signal cable connection.....	30
4.4 The test of setting up an electric circuit.....	31
<b>5 Product Maintenance.....</b>	<b>32</b>
5.1 Preparation Tools.....	32
5.2 Module maintenance.....	33
5.3 HUB board/Receiving card/PSU maintenance.....	33
5.4 Product maintenance precautions.....	35
5.5 Troubleshooting.....	37

## SAFETY INFORMATION



**WARNING!**

Please read the safety measures listed in this section carefully before installing, powering on, operating, or doing maintenance on this product.

The following marks on the product and in this manual indicate important safety measures.



**WARNING:** Be sure to understand and follow all safety guidelines, safety instructions, warnings and precautions listed in this manual. This product is for professional use only! This product may result in serious injury or death due to fire hazard, electric shock, and crushing hazard.



Please read this manual carefully before installing, powering up, operating and maintenance of this product. Follow safety instructions in this manual and on the product. If you have any questions, please seek help from Absen.



**Beware of Electric Shock!**

- To prevent electric shock the device must be properly grounded during installation. Do not ignore using the grounding plug, or else there is a risk of electric shock.
- During a lightning storm, please disconnect the device's power supply, or provide other suitable lightning protection. If the equipment is not in use for a long time, please unplug the power cable.
- When performing any installation or maintenance work (e.g. removing the fuses, etc.) make sure to turn off the master switch.
- Disconnect AC power when the product is not in use, or before disassembling, or installing the product.
- The AC power used in this product must comply with local building and electrical codes, and should be equipped with overload and ground fault protection.
- The main power switch should be installed at a location near the product and should be clearly visible and easily reached. This way in case of any failure the power can be promptly disconnected.
- Before using this product check all electrical distribution equipment, cables and all connected devices, and make sure all meet current requirements.
- Use appropriate power cables. Please select the appropriate power cable according to the required power and current capacity, and ensure the power cable is not damaged, aged or wet.

If any overheating occurs, replace power cable immediately.

- For any other questions, please consult a professional.



Beware of Fire!

- Use a circuit breaker or fuse protection to avoid fire caused by power supply cables overloading.
- Maintain good ventilation around the display screen, controller, power supply and other devices, and keep a minimum 0.1 meter gap with other objects.
- Do not stick or hang anything on the screen.
- Do not modify the product, do not add or remove parts.
- Do not use the product in case ambient temperature is over 55 °C.



Beware of Injury!



- Warning: Wear a helmet to avoid injury.
- Ensure any structures used to support, fix and connect the equipment can withstand at least 10 times the weight of all the equipment.
- When stacking products, please hold products firmly to prevent tipping or falling.
- Ensure all components and steel frames are securely installed.
- When installing, repairing, or moving the product, ensure the working area is free of obstacles, and ensure the working platform is securely and stably fixed.
- In the absence of proper eye protection, please do not look directly at the lit screen from within a 1 meter distance.
- Do not use any optical devices that have converging functions to look at the screen to avoid burning the eyes.



WARNING: Beware of suspended loads.



LED lamps used in the module are sensitive and can be damaged by ESD (electrostatic discharge). To prevent damage to LED lamps, do not touch when the device is running or switched off.



WARNING: The manufacturer shall not bear any responsibility for any incorrect, inappropriate, irresponsible or unsafe system installation.

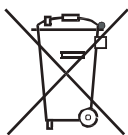

Product Disposal

- Any component that has a recycling bin label can be recycled.
- For more information on collecting, reusing and recycling, please contact the local or regional waste management unit.
- Please contact us directly for detailed environmental performance information.

---

**Warning: Changes or modifications to this unit not expressly approved by the party responsible for compliance could void the user' s authority to operate the equipment.**

**NOTE: This equipment has been tested and found to comply with the limits for a Class B digital device, pursuant to part 15 of the FCC Rules. These limits are designed to provide reasonable protection against harmful interference in a residential installation. This equipment generates, uses and can radiate radio frequency energy and, if not installed and used in accordance with the instructions, may cause harmful interference to radio communications. However, there is no guarantee that interference will not occur in a particular installation. If this equipment does cause harmful interference to radio or television reception, which can be determined by turning the equipment off and on, the user is encouraged to try to correct the interference by one or more of the following measures:**

- Reorient or relocate the receiving antenna.**
- Increase the separation between the equipment and receiver.**
- Connect the equipment into an outlet on a circuit different from that to which the receiver is connected.**
- Consult the dealer or an experienced radio/TV technician for help.**

**This Class B digital apparatus complies with Canadian ICES-003.  
This Class B digital apparatus complies with Canadian ICES-003.  
Cet appareil numerique de la classe B est conforme a la norme NMB-003 du Canada.**

# 1 Product Introduction

As a symbol of infinite possibilities, letter "X" becomes an exterior design element of the cabinet, and the Xs will form a "honeycomb", an Absen brand element. The unique design conveys Absen's confidence in its display expertise and product quality.

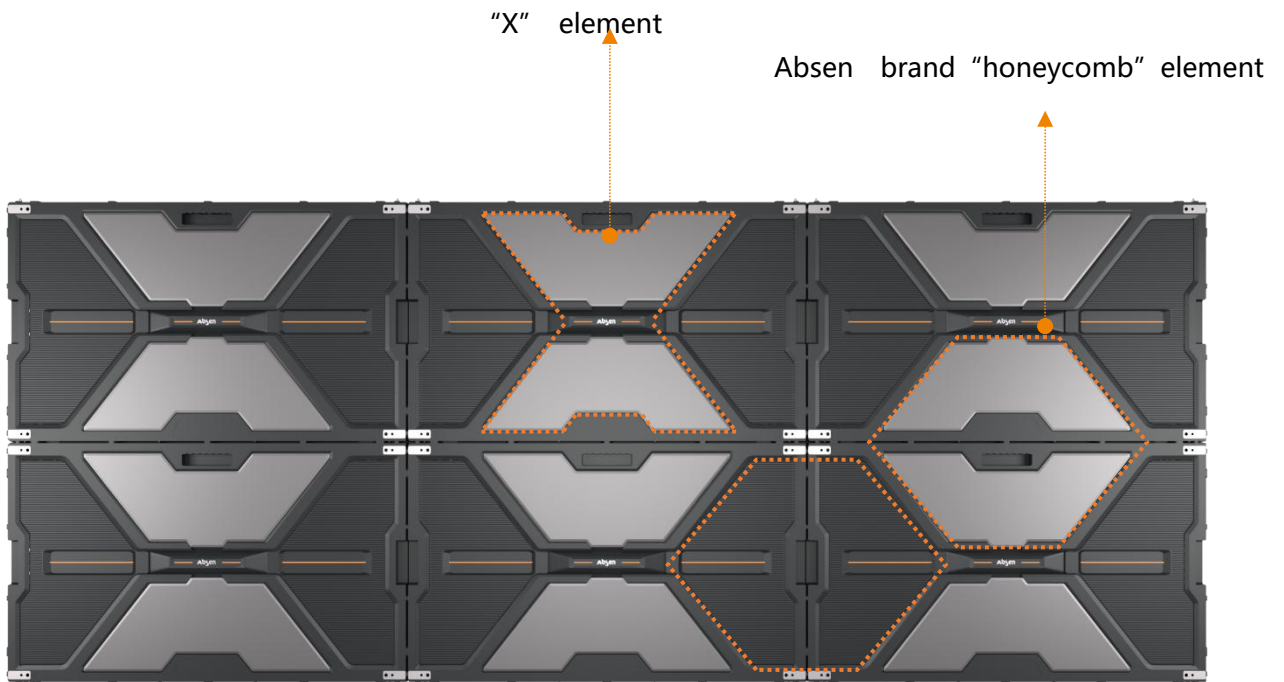

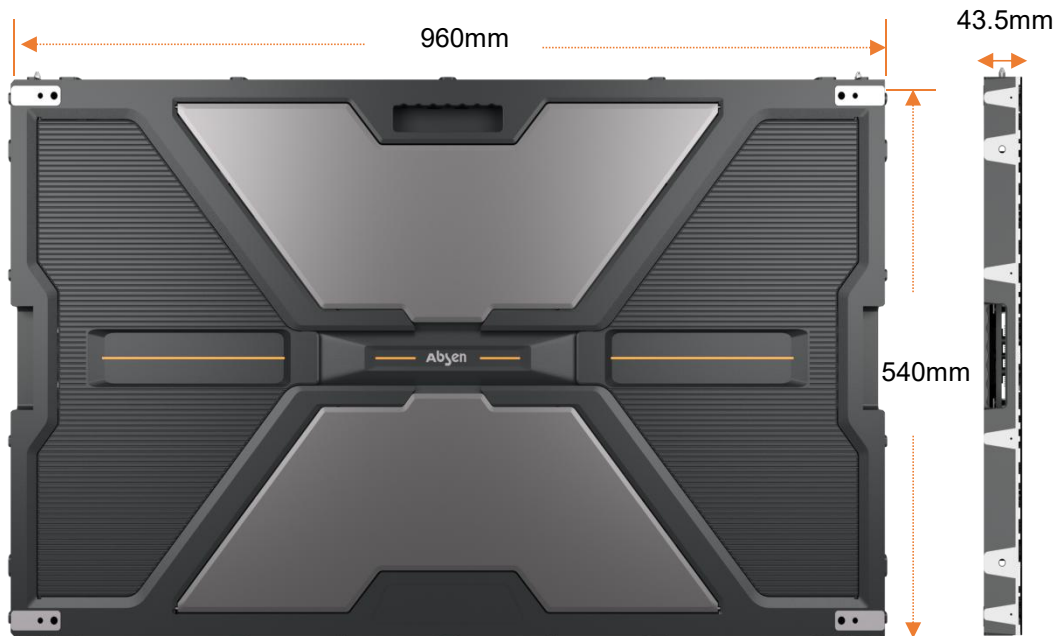

## 1.1 Product application scenarios

- This product can be widely used in the following application scenarios (indoor):
- Retail: display screen at the entrance of the store, quadrangular prism decorative screen inside the store, large display screen on the wall inside the store, etc.;
- Commercial real estate: shopping mall atrium, shopping mall entrance, shopping mall aisle, etc.;
- Enterprise: enterprise lobby, enterprise exhibition hall, enterprise conference room, monitoring center, etc.;
- Transportation: train/flight information display boards, advertising screens on both sides of the sidewalk, sky screens, quadrangular prism decorative screen, etc.;
- At the same time, it is also widely used in churches, education, theme parks, museums, science and technology museums, e-sports, entertainment, fixed studios and other indoor places.

---

## 1.2 Main features

### 1.2.1 Structural design:

- The module adopts the design of no bottom shell, and the splicing precision is higher.
- The connection between the module and the HUB adopts high-precision floating connectors, wireless plug-in installation, and supports adjusting the splicing gap between the modules.
- The display unit adopts die-casting aluminum cabinet, with high precision; the back cover is made of PC +10% glass fiber material, which has high strength and no deformation.
- The cabinet and power supply have no fan, and the design is silent.
- The cabinet has a built-in copper column for adjustment, which supports manual adjustment of the front and rear flatness between the modules.
- The cabinet supports XYZ three-axis and six-direction adjustment, and achieves better flatness between the cabinet and the cabinet.
- The carrying handle of the cabinet and the installation handles on both sides of the cabinet meet the ergonomic design, which improves the convenience of transportation and installation.
- According to the site conditions, you can choose full front or full rear installation, and supports hanging, wall mounting and stacking installation.
- The bottom of the cabinet has a structure design to protect the light, which reduces the drop of lights caused by landing and splicing installation, and the cabinet does not lean forward or backward.
- The rear cover of the cabinet adopts rotary clamshell design, which can meet the requirements of quick rear installation, rear wiring and rear maintenance without removing the cover.
- Product comes standard with ultra-thin and textured trim pieces, Metal spraying ultra-thin standard trim pieces solution for enhanced look and esthetic feeling.
- The receiving card is connected with high-precision connectors, which is stable, reliable and convenient for maintenance.

### 1.2.2 Feature design:

- The product has dual brightness configuration, the 800nits brightness configuration meets the needs of ordinary indoor display, and the 1500nits brightness(excluding NX1.5) configuration meets the indoor scenes with high ambient light, such as shopping mall atrium, corporate lobbies, etc.



- 
- Large cabinet (960\*540mm) supports signal and power backup, dual receiving card and dual power supply configuration.
  - The cabinet (960\*540mm) pixel design meets the 16:9 ratio.
  - Adopt advanced blanking circuit design, no "caterpillar", "ghosting" phenomenon.
  - Using PWM constant current output high-end chip to achieve high grayscale at low brightness, full color and accurate details.
  - Adopt Absen A5C+ calibration technology, A5C+ pixel by pixel calibration technology eliminates the difference in brightness and chromaticity within and between panels, improves the uniformity of display, and reproduces flawless images. Module comes with calibration parameters.
  - With black screen and partial black screen dynamic energy saving function, the dynamic energy saving mode is automatically turned on during use, which is efficient and energy saving (only supported by P1.5&P1.8).
  - The product meets the EMC Class B civil level radiation requirements.
  - Passed the TÜV Rheinland low blue light certification, filters out harmful blue light, and protects eyes.
  - The cabinet supports signal loop backup.
  - The attenuation coefficient is set for a single module, so that there is no chromatic aberration after maintenance and replacement.
  - The software has the function of adjusting the light and dark lines with one key.
  - The calibration data can be stored in the receiving card and the module itself, and the software can read back the data from both.

## 1.3 Product parameters

### 1.3.1 800nits brightness configuration specification

- Cabinet size: 960\*540\*43.5mm

Parameters		NX1.5	NX1.8	NX2.5	NX3.7
Physical Parameter	Diode Type	SMD1212	SMD1515	SMD1515	SMD1515
	Pixel Pitch (mm)	1.5	1.875	2.5	3.75
	Panel Dimensions (WxHxD)/(mm)	960*540*43.5			
	Pixel Per Panel	640*360	512*288	384*216	256*144
	Panel Weight (kg)	10.5	10.5	10.4	10.3
	Panel Material	Die-cast aluminum			
	Module Dimensions (WxH)/(mm)	240*270			
Optical Parameter	Brightness (nit)	800nits			
	Refresh Rate (Hz)	3840			
	Gray scale (bit)	16 bit (Internal processing 16bit, hardware up to 14bit)			
	Contrast Ratio	4000:1	4000:1	4500:1	5200:1
	Color Temperature (K)	6500			
	Viewing Angle (H/V) (°)	150/150	160/160	160/160	160/160
	Driving Type	1/45	1/36	1/27	1/18
	AC Operating Voltage (V)	100~240			
	Power Consumption (Max./Avg.)(W/m <sup>2</sup> )	480/160	420/140	450/150	480/160
Application Parameter	Storage Temperature	-40 ~ +60			
	Operating Temperature	-10 ~ +40			
	Storage Humidity	10% ~ 85%			
	Operating Humidity	10% ~ 80%			
	LED Lifetime	100000			
Installation/Maintenance	Module maintenance	Full front/Full rear			
	Power & other maintenance	Full Front /Full Rear			
	Installation method	Hanging, Wall mounting and Stacking			Full Front /Full Rear installation
EMC level	CLASS B (The dual backup version only supports Class A)				
Certification	CCC/CE/FCC/ETL/ROHS/TUV/CB/UKCA				

Note: Power consumption tolerance:  $\pm 15\%$ , according to the actual situation.

### 1.3.2 1500nits brightness configuration specification

- Cabinet size: 960\*540\*43.5mm

Parameters		NX1.8	NX2.5	NX3.7
Physical Parameter	Diode Type	SMD1515	SMD1515	SMD1515
	Pixel Pitch (mm)	1.875	2.5	3.75
	Panel Dimensions (WxHxD)/(mm)	960*540*43.5		
	Pixel Per Panel	512*288	384*216	256*144
	Panel Weight (kg)	10.5	10.4	10.3
	Panel Material	Die-cast aluminum		
	Module Dimensions (WxH)/(mm)	240*270		
Optical Parameter	Brightness (nit)	1500nits		
	Refresh Rate (Hz)	3840		
	Gray scale (bit)	16 bit (Internal processing 16bit, hardware up to 14bit)		
	Contrast Ratio	6000:1	7600:1	7400:1
	Color Temperature (K)	6500		
	Viewing Angle (H/V) (°)	160/160	160/160	160/160
	Driving Type	1/36	1/27	1/18
	AC Operating Voltage (V)	100~240		
	Power Consumption (Max./Avg.)(W/m <sup>2</sup> )	606/202	534/178	609/203
Application Parameter	Storage Temperature	-40 ~ +60		
	Operating Temperature	-10 ~ +40		
	Storage Humidity	10% ~ 85%		
	Operating Humidity	10% ~ 80%		
	LED Lifetime	100000		
Installation/Maintenance	Module maintenance	Full front/Full rear		
	Power & other maintenance	Full front/Full rear		
	Installation method	Hanging, Wall mounting and Stacking		Full Front /Full Rear installation
EMC level	CLASS B (The dual backup version only supports Class A)			
Certification	CCC/CE/FCC/ETL/ROHS/TUV/CB/UKCA			

Note: Power consumption tolerance:  $\pm 15\%$ , according to the actual situation.

## 2 Introduction of Product Components

### 2.1 Product size introduction

#### 2.1.1 Cabinet size drawing

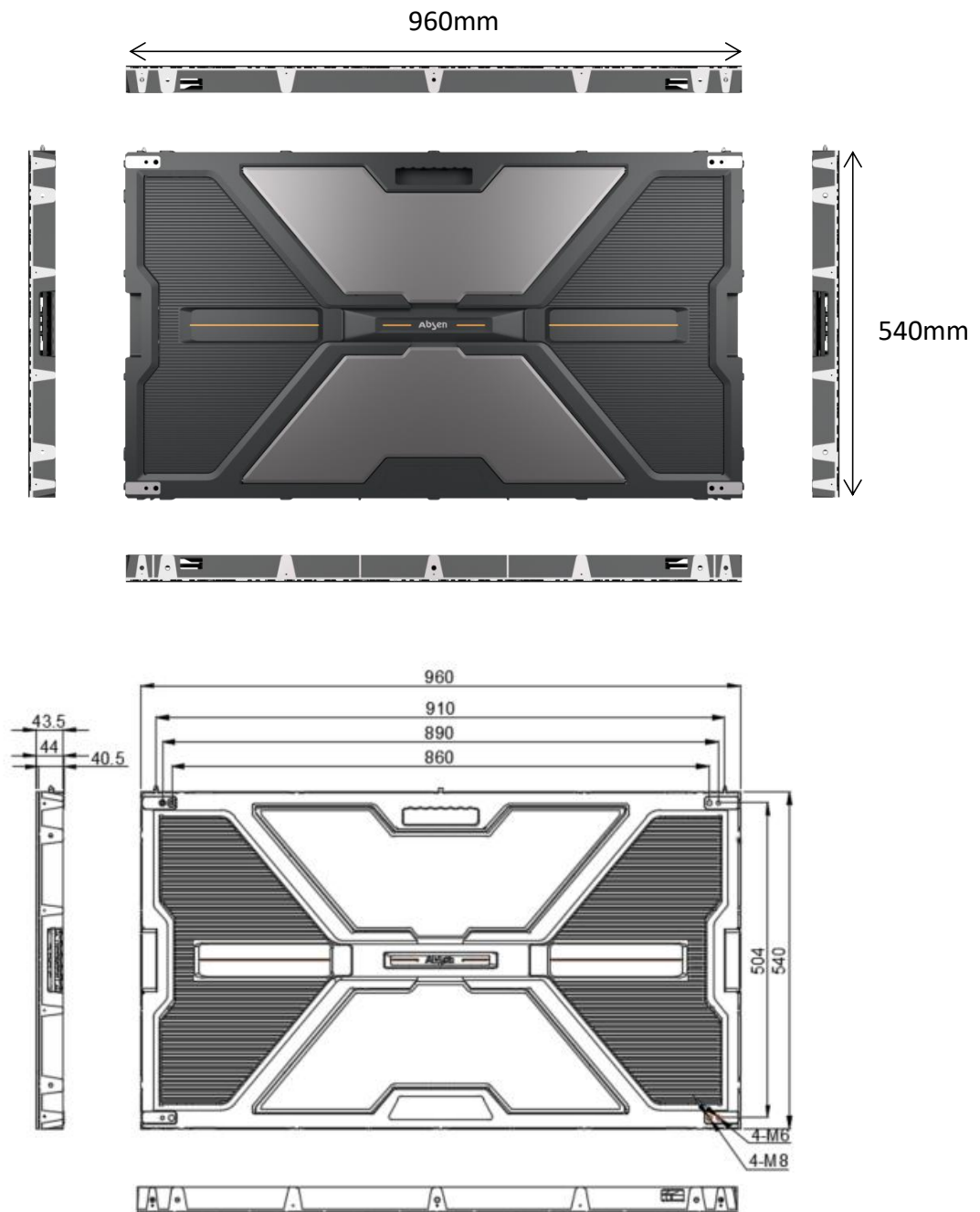

2.1.2 Module size drawing

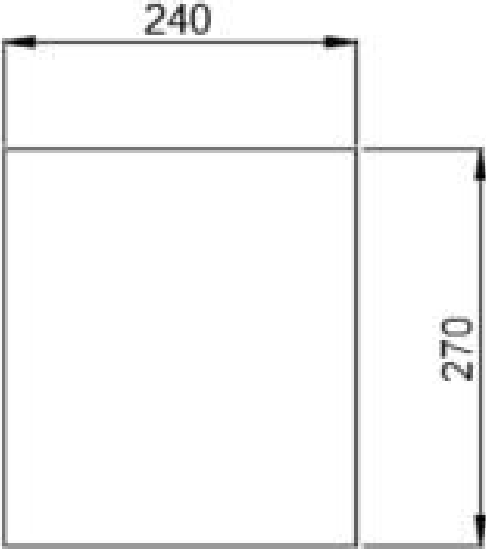
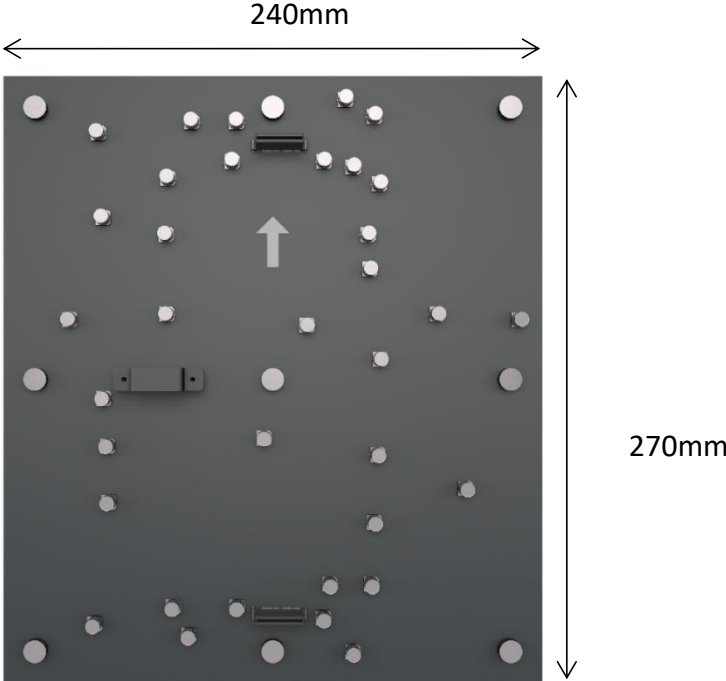

## 2.2 Introduction of cabinet components

Cabinet size: 960\*540mm

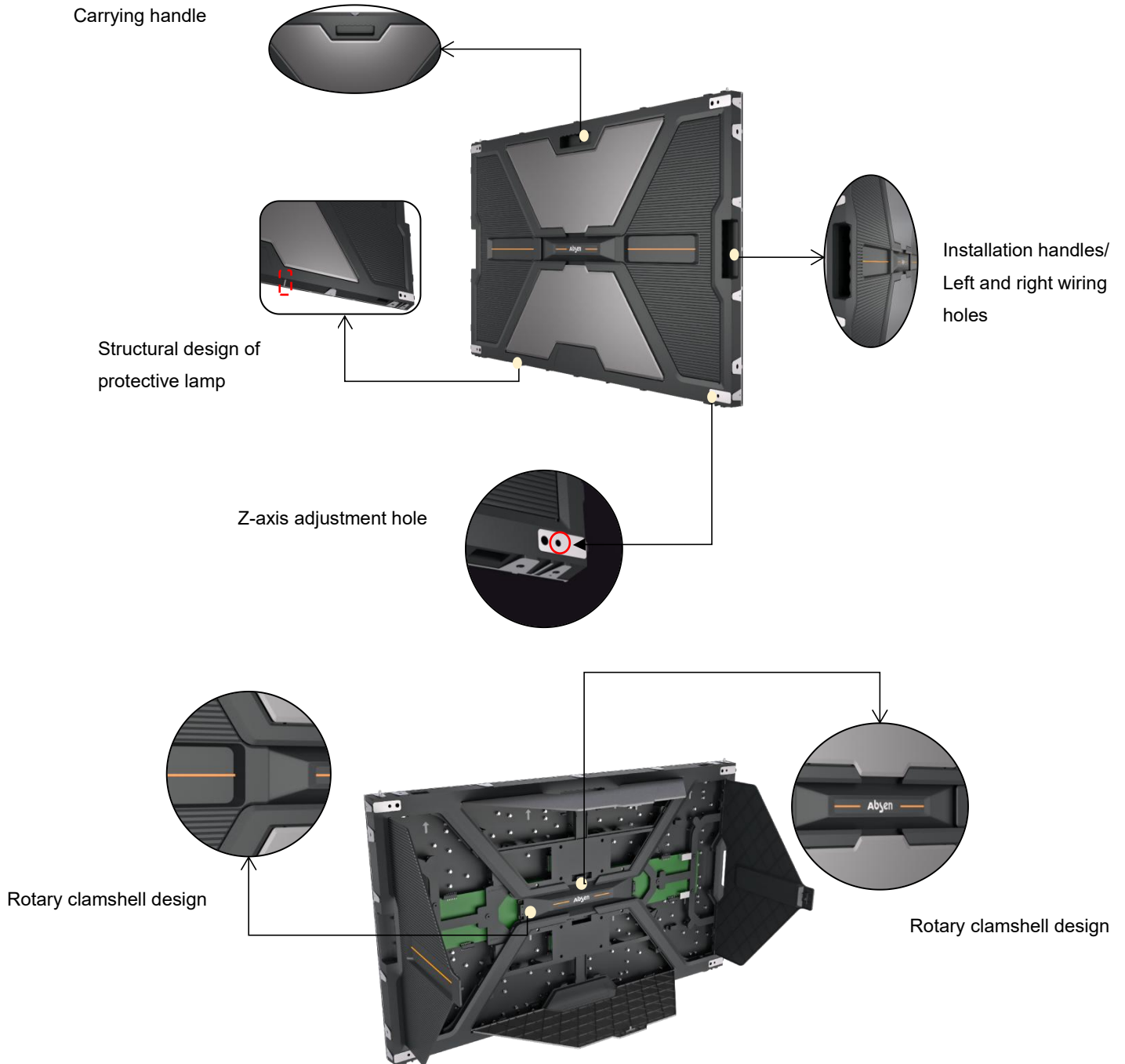

## 2.3 Introduction to Splicing Scheme

### 2.3.1 Flat screen design

1. Join together by 960\*540mm big panels

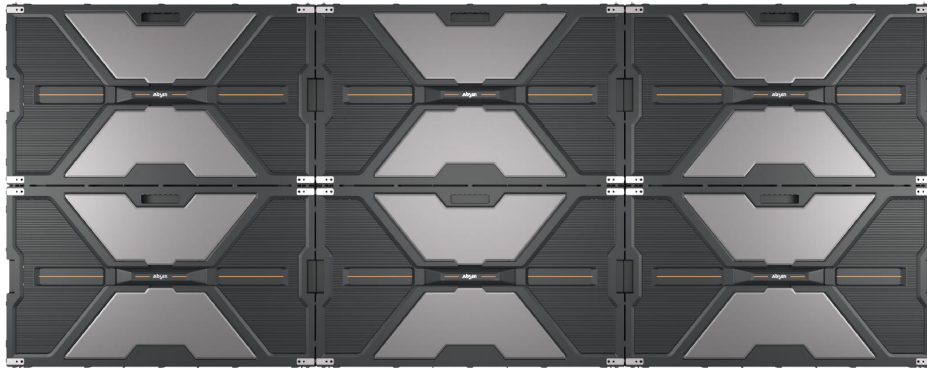

2. Join together by 960\*540mm big panels and N- in-1 small panels

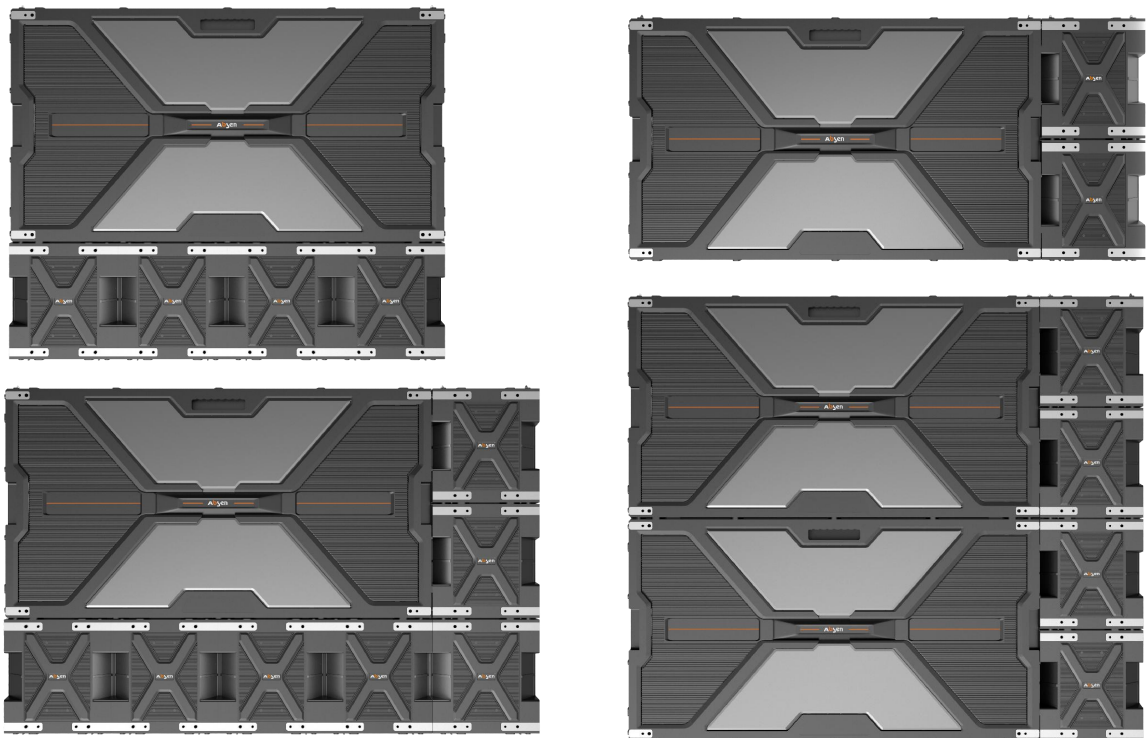

### 2.3.2 Right angle screen design

By N-in-1 small panels to achieve right angle

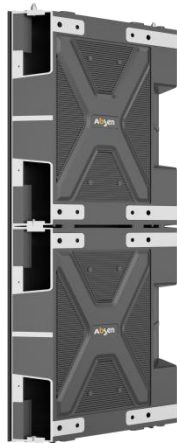
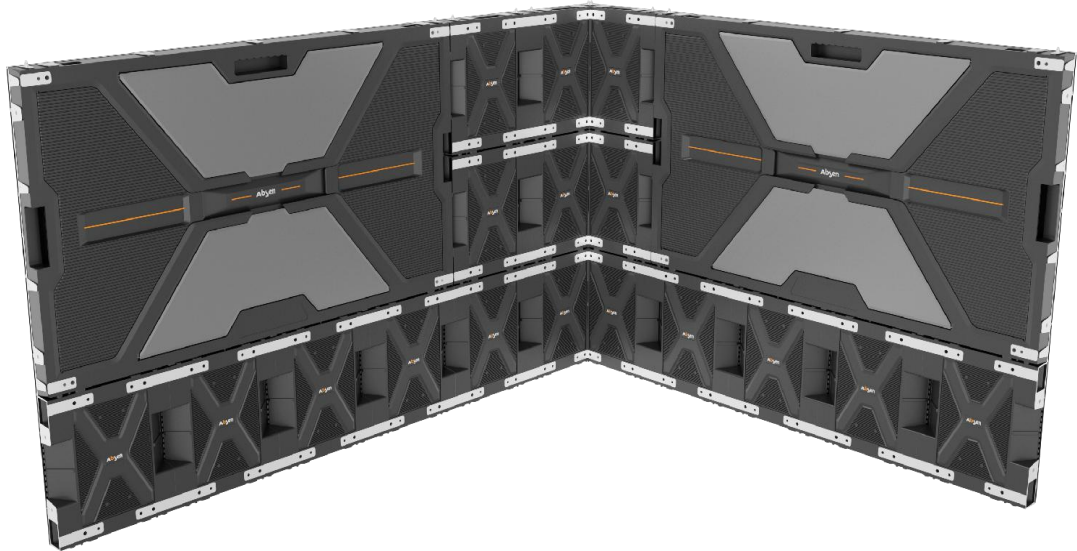

left cut panels

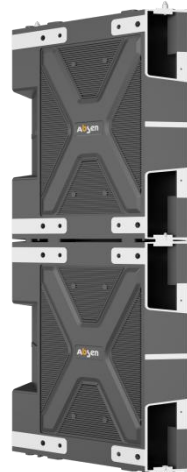
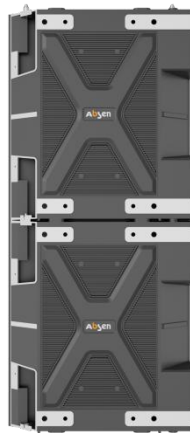

right cut panels



---

### 2.3.3 Arc-shaped screen design

Joining the small panels with a 45 degree chamfer on both sides to achieve inner and outer arcs

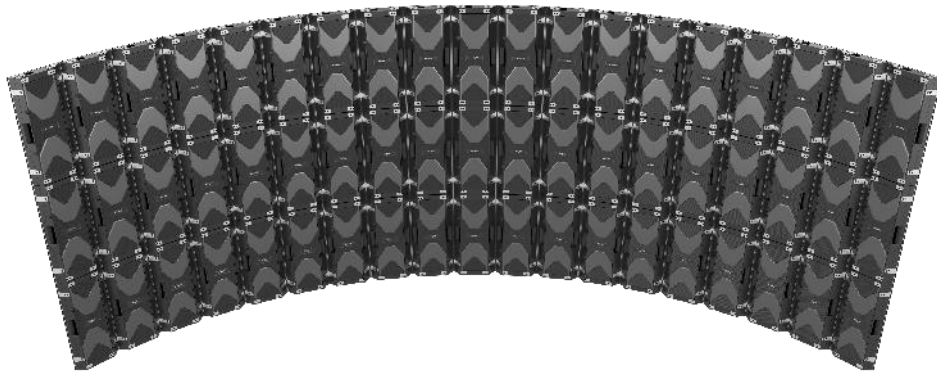

### 3 Product Installation

This product supports full front installation and full rear installation. The upper and lower/left and right screws connecting the cabinet can be installed from the front or back of the screen, and supports wiring from the front or back of the screen.

The installation method is optional hanging, wall mounting and stacking installation.

	Tool type	function	picture
<b>Installation tool list</b>	knife	Open the cabinet	
	Front maintenance tool	Install& maintain the LED module	
	Socket hexagon wrench	Install the screws between the LED cabinets	
	spanner	Install bolts	
	PH2 screwdriver	Maintenance and disassembly Module & power supply	
	multimeter	Measuring power cable and distribution cabinet	
	Laser level	Measuring installation position	
	Spirit level	Check the flatness of the cabinet installation	
	tape measure	Measure the distance	
	Hexagon screwdriver	Install and remove the hexagon socket screws	

### 3.1 stacking installation

#### 3.1.1 Installation accessories are as follows:

Installation Type	Usage Description
Rear installation	NX plates for rear installation 169X60X6.0
	installation screws for fixing plates HSM8*55
	flatness adjustment screws HSM6*50
Front installation	NX plates for front installation 169X54X6.0
	installation screws for fixing plates HSM6*60
	flatness adjustment screws HSM6*60



Plate for rear installation

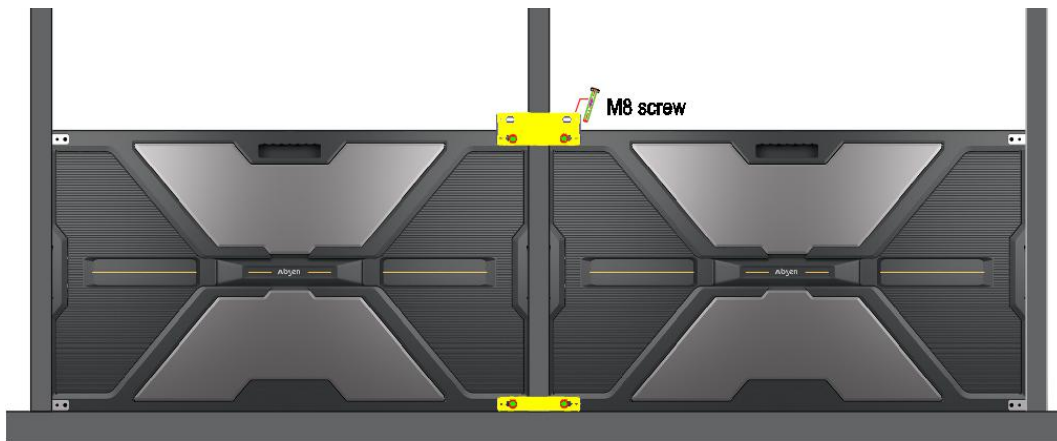

Plate for front installation

#### 3.1.2 Installation steps:

1. Take out the NX cabinet frame from the package, first install the bottom first layer of the cabinet, install it from the middle to both sides, and then up, support the cabinet to be locked on the steel structure from the front of the cabinet or from the back of the cabinet;

Front Installation : M6 \* 60mm screws pass through the panel, with a width of 40mm square, and are locked on the connecting plate, with 4pcs per panel;  
 Rear Installation: M8 \* 55mm screws pass through the connecting plate, with a width of 40mm square, and locked into the panel installation hole, 4pcs/panel;



2. Install the adjacent cabinets in sequence. Use M8\*40mm bolts to fix the left and right of the cabinets, and then tighten them with an Allen wrench tool. It supports connection from the front of the cabinet or from the back of the cabinet (open the back cover of the cabinet).  
 Note: During the installation process, ensure the flatness of the cabinet structure splicing.

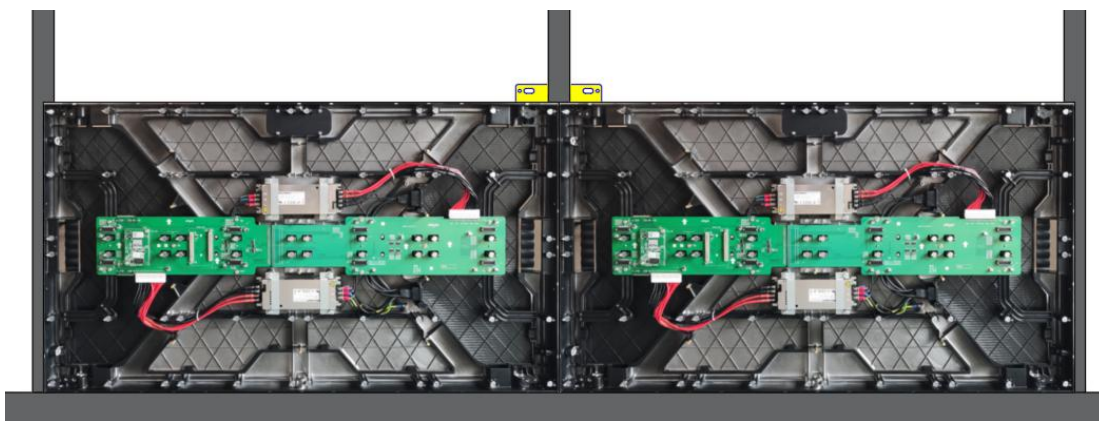

3. Install the second layer of the cabinet, first use M8\*40mm bolts to fix the upper and lower parts of the cabinet, and then use the Allen wrench tool to tighten the screws; then use the connecting plate to fix the cabinet and the steel structure.

Note: During the installation process, ensure the flatness of the cabinet structure splicing.

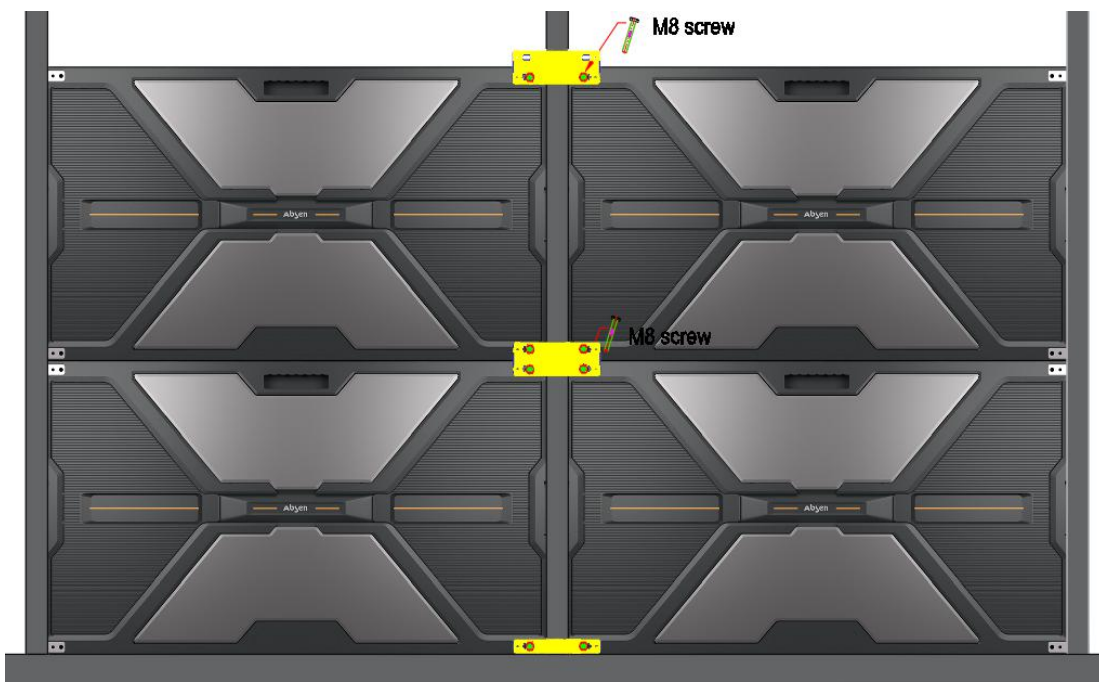
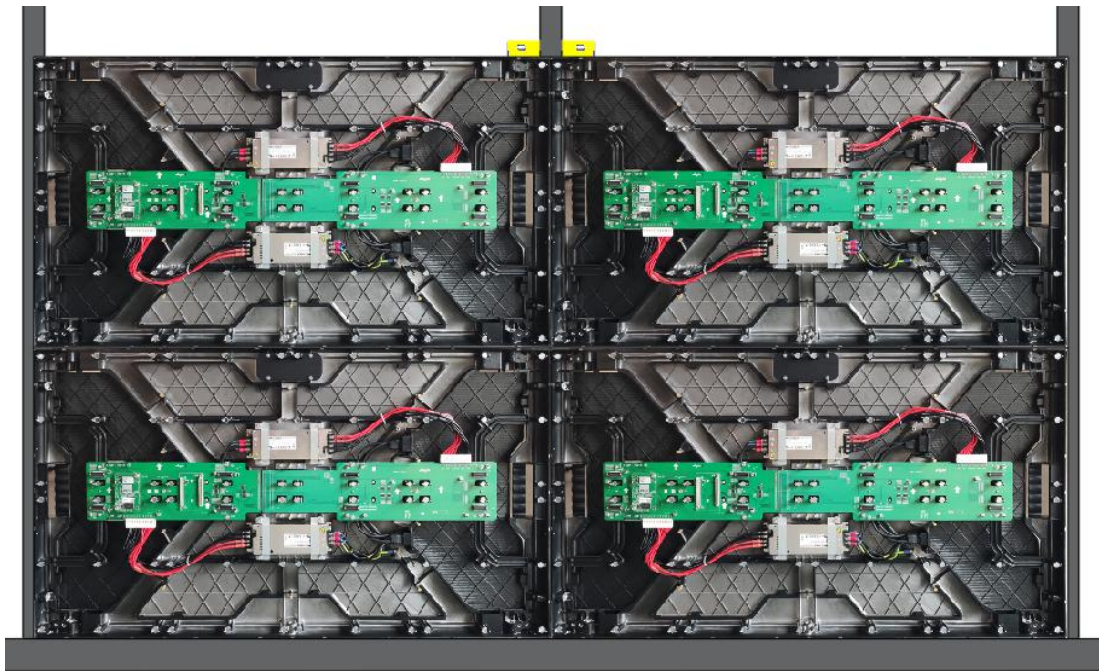

4. Follow the above steps to complete the installation of all cabinet structures.
5. After installing the power cable and network cable of the cabinet and checking that they are correct, install the module.

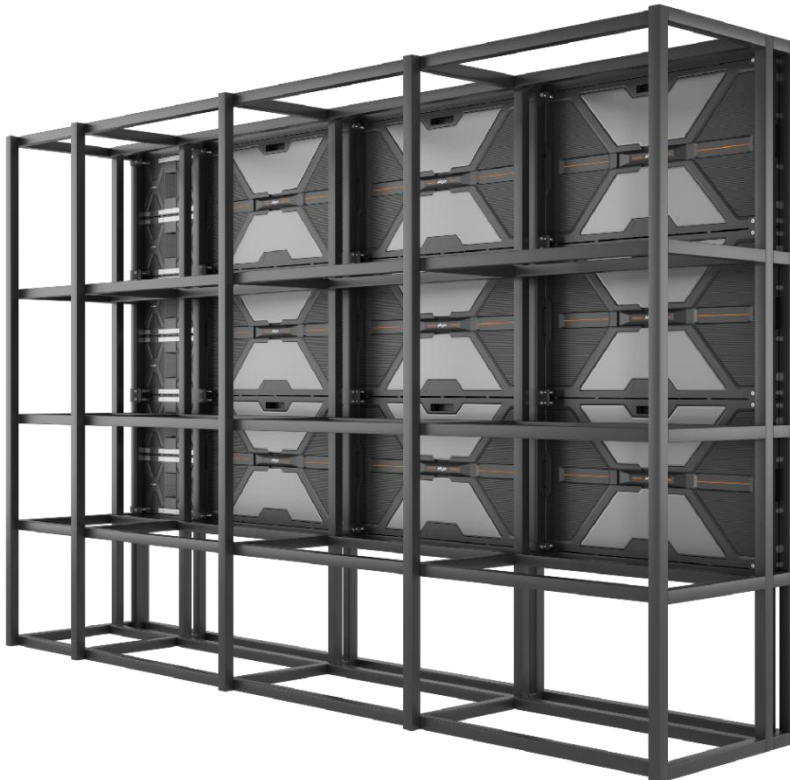



The large and small panels are connected by M8 \* 40mm connecting screws

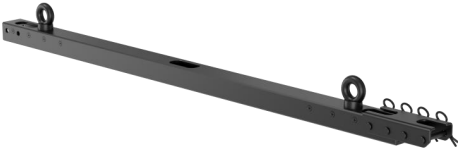

## 3.2 Hanging installation

### 3.2.1 Installation accessories are as follows:

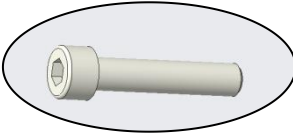
Specification	Purpose	Schematic
960mm	Big cabinet (960X540mm) Small cabinet(960X270mm)	
240mm	Small cabinet(240X540/810/1080mm)	
M8*40mm	The hexagon socket head machine screw is used to connect the hanging beam and the cabinet	

### 3.2.2 Installation steps:

1. First, fix the hanging beam on the truss or steel structure with the aircraft belt or wire rope, and connect the left and right hanging beams with connecting blocks, and keep them on the same horizontal line;

2. Align the positioning column of the first-layer cabinet with the positioning hole of the hanging beam, and use M8\*40mm screws to lock the cabinet and the hanging beam. Use M8\*40mm screws to connect and lock between the left and right adjacent cabinets. When installing, pay attention to check the flatness of the left and right cabinets, and lock and fix after confirming that they are flat;

Note: Use connecting blocks to install between large and small cabinets.  
Mounting screw: cylindrical inner hexagon full thread machine screw M6\*30mm

3. Install the cabinets of the second layer in sequence according to the above operation methods, and use screws to lock the adjacent cabinets. When installing, pay attention to check the flatness between the top and bottom and left and right of the cabinet, and lock and fix after confirming that it is flat;
4. Repeat the above steps to complete the installation of all cabinet frames;
5. Install the power cable and signal cable according to the power supply and signal routing design scheme, and then install the LED module after power-on inspection and confirmation.

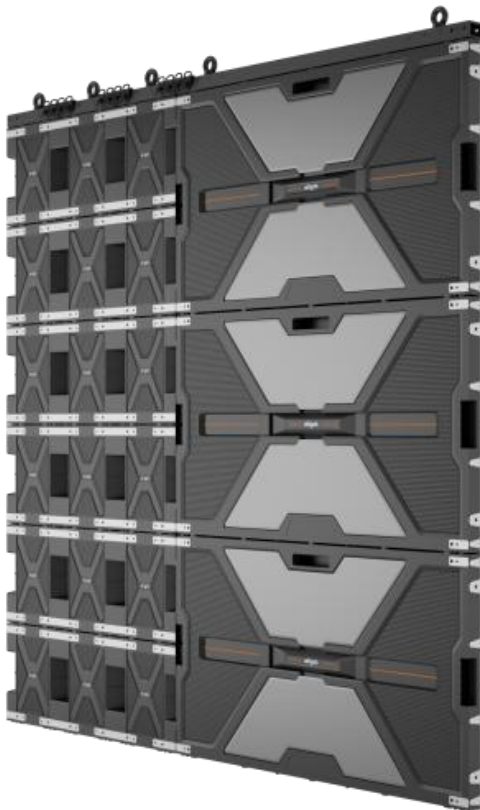



### 3.3 Wall mounting

#### 3.3.1 The frame kit accessories are as follows:

Type	Purpose
Big cabinet (960*540mm) frame kit	Suitable for 240*540 cabinet structure
Small cabinet (240*540/810/1080mm) frame kit	Longitudinal 2-in-1 cabinet frame kit, 535x235x23.5mm
	Longitudinal 3-in-1 cabinet frame kit, 805x235x23.5mm
	Longitudinal 4-in-1 cabinet frame kit, 1075x235x23.5mm
	Horizontal 4-in-1 cabinet frame kit, 955x265x23.5mm
Hanging pin	Hang the cabinet on the frame with the hanging pin

#### 3.3.2 Installation steps:

1. According to the cabinet arrangement and the drawing of the frame, fix the frame on the wall with M6 external hexagon self-tapping screws. During the installation process, use a laser level and a spirit level to check and confirm the flatness of the frame. Install the frame from the bottom left corner, starting from the bottom first row, and then upward; From bottom to top, from left to right.

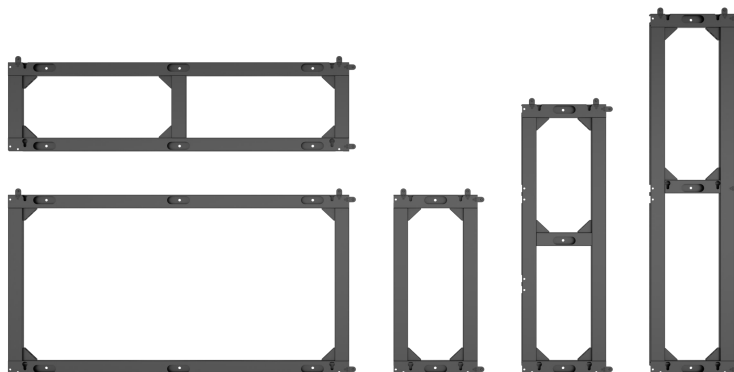

2. Install the NX special hanging pin in the M8 hole on the back of the cabinet, and install 4 pieces per frame.



3. After installing all the frames, install the cabinet frame on the frame kit, install it layer by layer from bottom to top, and fasten the connecting screws between the cabinets to fix the cabinet.

Note: Arrange the main power cable and main network cable of the screen to the corresponding positions in advance, and ensure the flatness between the cabinets during the installation of the cabinet frame.

4. After installing all the cabinets, connect the signal cable and power cable.



5. When installing the module, it should be installed according to the corresponding number of the module and the cabinet.  
 From the front of the big cabinet, the upper modules are XX-1, XX-2, XX-3, XX-4 from left to right, and the lower modules are XX-5, XX-6, XX-7, XX-8. (Note: "XX" represents the cabinet number, each cabinet has a different number)  
 From the front of the small cabinet, the upper module is XX-1, and the lower module is XX-2. (Note: "XX" represents the cabinet number, each cabinet has a different number)

## 3.4 Trim pieces installation

This product supports trim pieces installation, and the trim pieces and the cabinet are locked and fixed by external hexagonal combination machine screw HM3\*8.

### 3.4.1 The specification of the trim pieces name is as follows:

Trim pieces type	Description
960*540mm	Trim pieces specifications: 965*68*5, black
big panel: horizontal trim pieces	Trim pieces specifications: 960*68*5, black
960*540mm	Trim pieces specifications: 1080*68*5, black
240*540/810/1080mm	Trim pieces specifications: 540*68*5, black
big panel and vertical 2/3/4 in 1 small panel : vertical trim pieces	Trim pieces specifications: 545*68*5, black
240*540/810/1080mm  2/3/4 in 1 small panel : horizontal trim pieces	Trim pieces specifications: 480*68*5, black
	Trim pieces specifications: 240*68*5, black
	Trim pieces specifications: 245*68*5, black
	Trim pieces specifications: 485*68*5, black
960*270mm  4 in 1 small panel : horizontal trim pieces and vertical trim pieces	Trim pieces specifications: 965*68*5, black
	Trim pieces specifications: 960*68*5, black
	Trim pieces specifications: 275*68*5, black
	Trim pieces specifications: 270*68*5, black

### 3.4.2 Principles of the Trim pieces scheme:

1. The position of the upper left corner of the screen: the upper side is longer, the left side is shorter;
2. The lower left corner position of the screen: the left side is longer and the lower side is shorter;
3. The lower right corner position of the screen: the lower side is longer and the right side is shorter;
4. The upper right corner position of the screen: the right side is longer and the upper side is shorter;
5. The long edge covers the short edge;

### 3.4.3 Trim pieces Scheme diagram

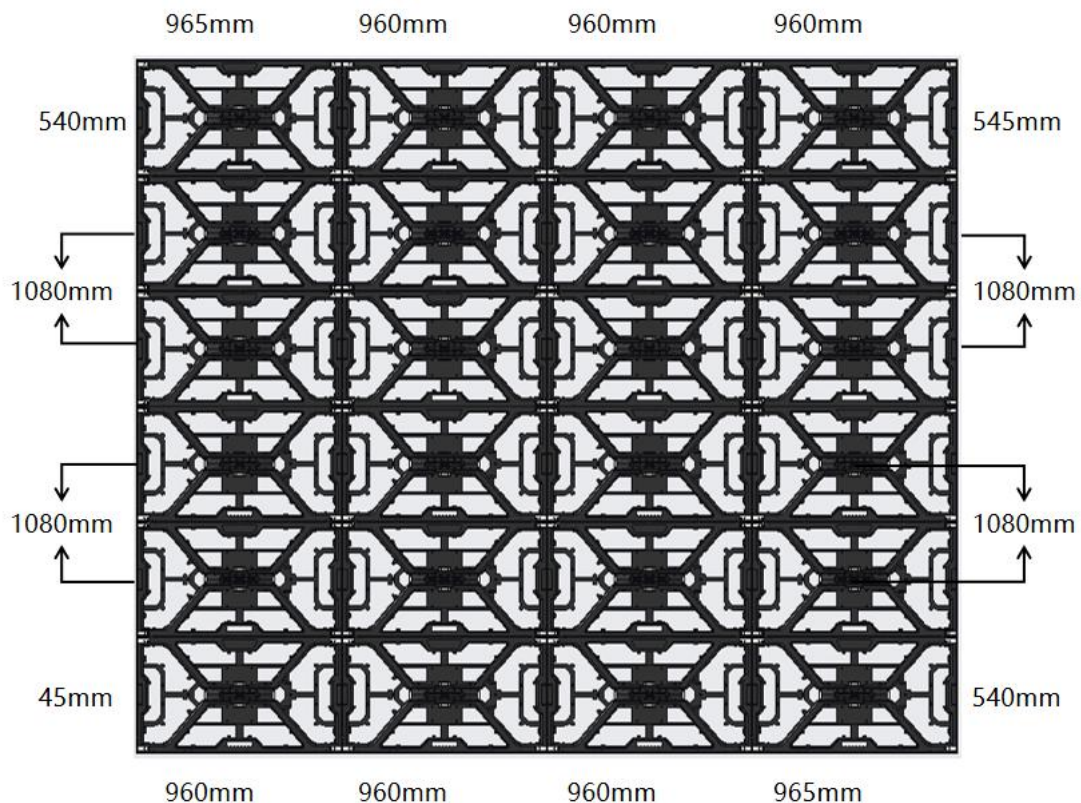

---

## 4 Product Wiring

### 4.1 Preparation before connection

Before connecting: Before supplying power to the entire screen, please carefully check whether the power cable between the cabinets is connected, and whether the main power cable between the screen and the distribution cabinet is properly connected; check and confirm the AC power input port of each cabinet "L" wire, "N" wire, and "PE" wire, confirm that there is no short circuit between the three (measured with a multimeter).

And before providing control signals, Please calculate the power cable connection scheme according to the maximum power consumption and select the appropriate power distribution cabinet or socket model. For specific options, please consult your electrician or power distribution cabinet manufacturer. The input voltage of the cabinet is 100-240V/AC, and a 3X1.5mm<sup>2</sup> power cable is used from the distribution cabinet to the cabinet. Please confirm the input voltage, different voltages and different product models, and each power cable carries a load of the cabinet The quantity will be different (when unable to confirm, please contact our customer service department!).

### 4.2 Power cable connection

When the input voltage is 220V, each power cable of NX1.5 can carry up to 7 cabinets; when the input voltage is 110V, each power cable can carry up to 3 cabinets.

The following takes a 3x3 NX1.5 cabinet as an example to introduce the connection method of the power cable:

9 NX1.5 cabinets are loaded by 3 main power cables, and each cable is loaded with 3 cabinets. First, connect the cabinets in series with the cabinet-connected power cables, and then use 3 x 1.5mm<sup>2</sup> power cables from the power distribution. The cabinet or socket is connected to the bottom cabinet.

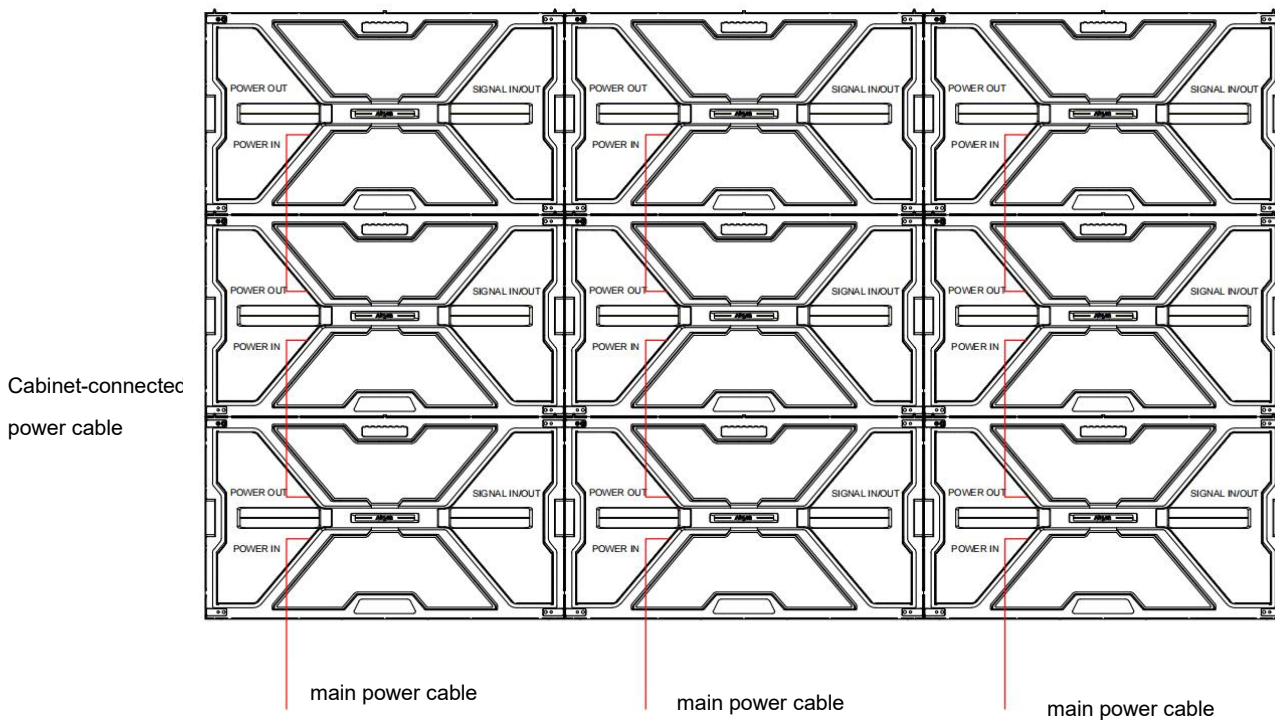

### 4.3 Signal cable connection

The signal cable adopts RJ45 CAT5 network cable, and the network cable interface of the cabinet can be used for input and output. Please calculate the resolution according to the pixels of each cabinet, and connect the signal cables according to the load range of the sending card.

Pay attention to the loading of each network port, the pixel range cannot exceed 655360 points (as shown below) .

The following takes a 3x3 NX1.8 cabinet as an example to introduce the connection method of the power cable:

The number of pixels of a single NX1.8 cabinet:  $512 \times 288 = 147456$ , 9 NX1.8 cabinets are loaded by 3 network cables, and each cable is loaded with 3 cabinets.

This product cannot store or display video content solely on itself. To perform normal work , the screen requires video source from the output device such as PC, laptop, media player, etc. and one or more sending cabinet to receive and feed the source to it.



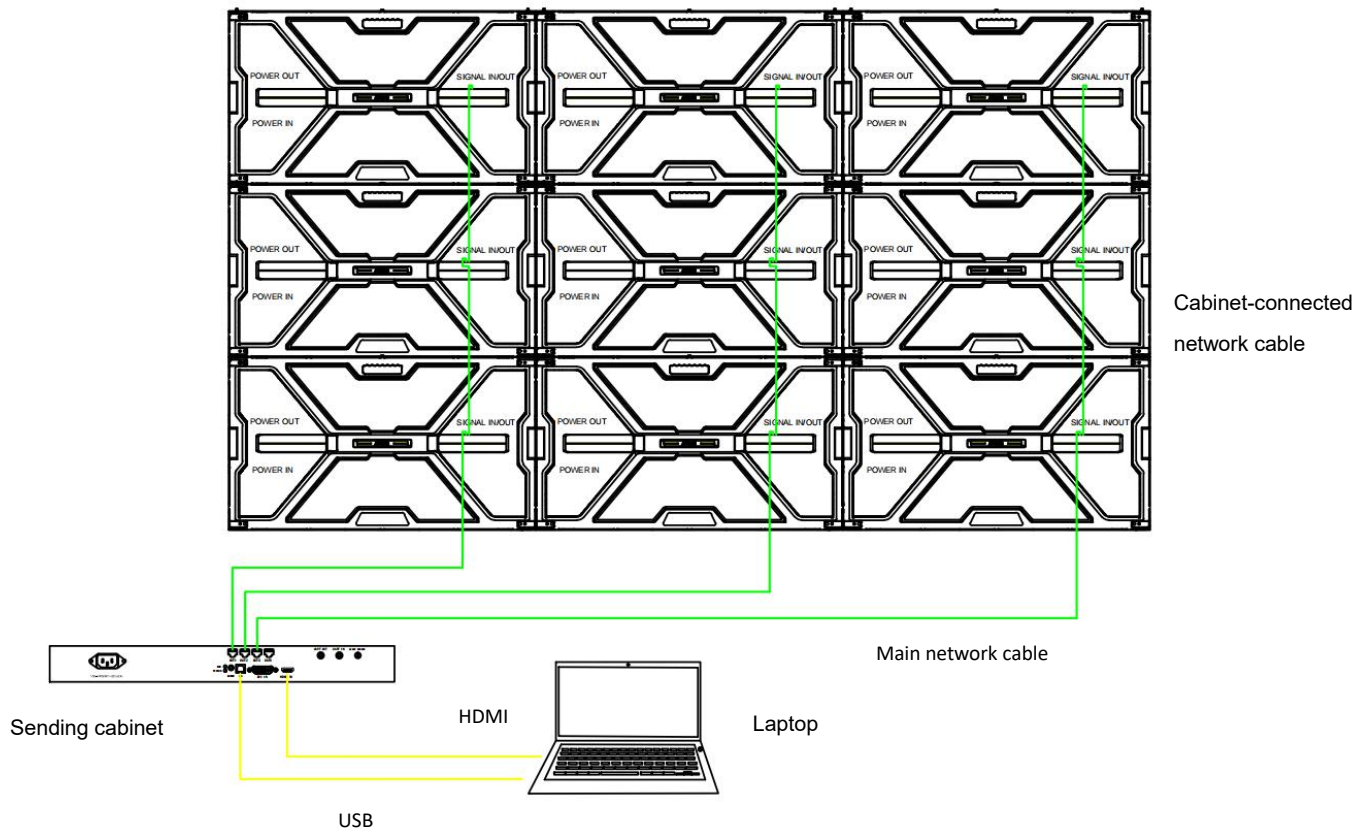

#### 4.4 The test of setting up an electric circuit

After the cabinet connection is completed, please use a multimeter to measure whether there is short circuit at the AC input (L/N/PE) and DC output (VCC/GND) of the power supply. If a short circuit is found, please check the circuit carefully. After ensuring the cable is normal, switch on the power to electrify the cabinets to work.

Note: Please refer to the software user manual for software operation.



# 5 Product Maintenance

## 5.1 Preparation Tools



Module front service tool  
Installation and removal LED module



multimeter  
Measure power cables and distribution cabinets



Allen key  
Removing/installing the screws of the HUB, receiving card and power supply



## 5.2 Module maintenance

- (1) The module can be quickly removed with a Module front service tool. Attach the front maintenance tool to the surface of the faulty module to be taken out, press the switch for 3 to 5 seconds, and then pull the tool out to take out the module;
- (2) Confirm the location of the faulty module, and place the module front maintenance tool in the area in the middle of the faulty module;
- (3) Press the switch for 3-5 seconds, take out the module with a little force and carefully take out the module in the direction perpendicular to the display surface;
- (4) Lightly install the spare module on the screen according to the upward direction.

### Precautions :

- The front maintenance tool should be placed in the middle of a single module and should not cross over to adjacent modules;
- When removing a module from the screen, hold the module with your hand to prevent the module from falling due to low power or accidental of the maintenance tool;
- During the disassembly and assembly process, care should be taken to avoid bumping into the corners of the module and damaging the lamp.

## 5.3 HUB board/Receiving card/PSU maintenance

### 5.3.1 Receiving card maintenance

- (1) First use the pre-maintenance tool to remove the module on the cabinet;
- (2) Then use the PH2 Phillips screwdriver to remove the 2 screws that fix the receiving card, and replace the faulty receiving card.

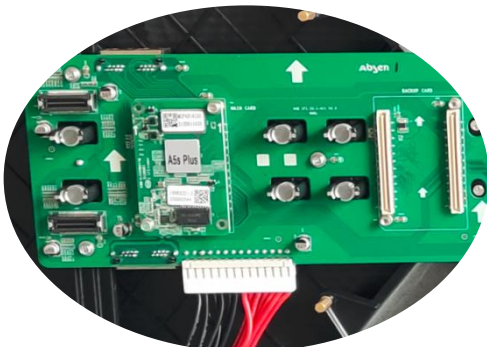

### 5.3.2 HUB board maintenance

- (1) First use the pre-maintenance tool to remove the module on the cabinet;
- (2) Remove the 5V power cable on the hub board;
- (3) Then use the PH2 Phillips screwdriver to remove the screws on the fixed hub board, then it can be removed and replaced.

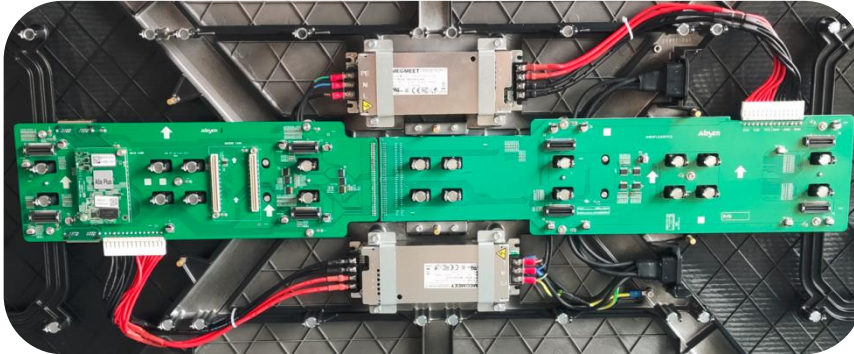

### 5.3.3 PSU maintenance

- (1) First use the pre-maintenance tool to remove the module on the cabinet;
- (2) Then use the PH2 Phillips screwdriver to remove the cable connecting the power supply and the screws that fix the power supply, and then remove and replace.

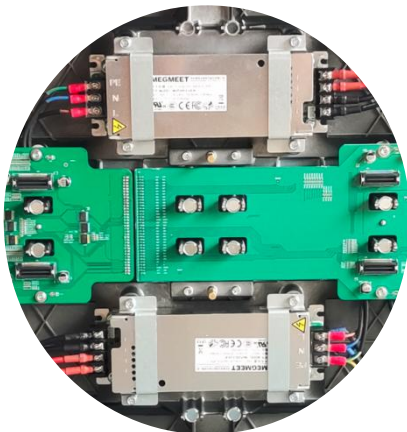

---

## 5.4 Product maintenance precautions

### 5.4.1 Precautions for switch on /off LED screen

- (1) Turn on the screen: first turn on the control computer to make it run normally, and then turn on the LED display.
- (2) Turn off the screen: first turn off the power of the LED screen, turn off the control software, and then turn off the computer correctly; (first turn off the computer without turning off the display screen, it will cause the screen to appear bright spots, burn the lamp, and have serious consequences)
- (3) The interval between switching screens should be greater than 5 minutes;
- (4) Avoid turning on the screen in the state of full white screen, because it is the maximum power state at this time, and its impact current to the entire power distribution system is the largest.

### 5.4.2 Precautions for power supply

- (1) The LED module is powered by DC +5V (working voltage: 4.2~5.2V), AC power is prohibited; the positive and negative poles of the power supply terminals are strictly prohibited to be reversed (note: once reversed, the product will be burnt out and even cause serious fire);
- (2) Power supply voltage of LED display: 220V±10% Frequency: 50HZ±5%;
- (3) Safe and reliable earth contact, reliable isolation between the earth wire and the neutral wire, and keep the power supply away from high-power spares;
- (4) If abnormalities such as short circuit, tripping, wire burning, smoke, etc. are found, the power-on test should not be repeated, and the problem should be found in time;
- (5) Keep the power supply stable, and do grounding protection to avoid lightning strikes, do not use it under harsh natural conditions, especially strong lightning weather;
- (6) The large screen power supply must be supplied step by step, because the maximum power state of the entire screen will have an impact on the entire power distribution system;
- (7) The LED display screen is not allowed to play the full white screen with the highest brightness for more than half an hour, so as not to cause excessive current, power cord heating, LED light damage, and affect the life of the display screen. It is recommended to play dynamic videos;
- (8) During the use of LED display products, the power supply should not be turned on and off continuously, and there should be at least 1 minute

- 
- between the two operations;
- (9) Non-professionals are forbidden to touch the internal wiring of the large screen of the LED display to avoid electric shock or damage to the wiring.

### 5.4.3 Notes on cleaning

- (1) Regular cleaning and maintenance: The indoor fine pitch LED display screen will be used for a long time, and more dust will accumulate on the screen. This needs to be cleaned regularly and in time to prevent it from affecting the viewing effect;
- (2) To clean the surface of the module, please use a soft brush and wipe gently. It is forbidden to use any liquid substance to clean the surface of the LED module, otherwise the LED may be damaged;
- (3) Wipe correctly: the surface of the large LED display screen cannot be wiped with alcohol or directly with a damp cloth. It is recommended to use brushes and vacuum cleaners to remove dust.

### 5.4.4 Moisture-proof and storage requirements

- (1) Storage temperature requirements: ambient temperature  $-20^{\circ}\text{C}\leq t\leq 50^{\circ}\text{C}$ . After the package is opened, the LED products must be stored in an environment with a temperature of  $<30^{\circ}\text{C}$  and a humidity of  $<70\%\text{RH}$ ;
- (2) According to the environmental conditions of the display screen and the control part, avoid insect bites, and put anti-rodent drugs if necessary;
- (3) The LED display should not be turned off for a long time. In a high-humidity environment, if the display is not used for more than 3 days, the pre-heating method should be used each time the display is turned on: 30%-50% brightness is preheated 4 -8 hours, then adjust to normal brightness (80%-100%) to light up the screen, so as to remove moisture so that there is no abnormality during use; if the screen has not been used for more than 7 days, every time the screen is turned on Need to adopt the pre-heating method: 30%-50% of the brightness is preheated for more than 12 hours, and then adjusted to normal brightness (80%-100%) to light up the screen, so as to remove the moisture, so that there is no abnormal.
- (4) The large LED screen needs to be checked regularly to see if it is working properly. If the circuit is damaged, it should be repaired or replaced in time. The main control computer and other related equipment should be placed in an air-conditioned and dusty room to ensure the computer's ventilation and heat dissipation and stable operation. Non-professionals are forbidden to touch the internal wiring of the screen to avoid electric shock or damage to the wiring. If there is a problem, you should ask a professional for

inspection and repair.

## 5.5 Troubleshooting

No.	Common faults	Solution
1	Some modules are not lighting on	1. Check whether the power plug of the corresponding module is tightly inserted;
		2. Check whether the power cable of the corresponding module is burnt out;
		3. Check whether the switch power supply of the corresponding module has no output;
		4. Check whether the flat cable of the corresponding module is malfunctioning;
		5. Replace the flat cable of the corresponding module;
		6. Replace the module;
		7. Replace the receiving card;
		8. Send rcfg file;
2	The whole screen is not lighting on	1. Check whether the screen power is on;
		2. Check whether the DVI cable or HDMI cable is loose;
		3. Check whether the main data cable is inserted tightly;
		4. Check whether the sending card is powered on and whether the running indicator is flashing;
		5. Replace the sending card;
		6. Connecting the computer to an LCD display, check whether there is output on video card;
		7. Update the video card driver;
		8. Replace the computer;
3	Screen show scrambled image	1. Check whether the power plug of the receiving card is tightly inserted;
		2. Check whether the power cable of the receiving card is burnt out;
		3. Check whether the power supply has no output;
		4. Check the data cable of the receiving card;
		5. Replace the data cable;
		6. Send the rcfg file;
		7. Upgrade the firmware version of the receiving card;
		8. Replace the receiving card;
4	Chromatic aberration between modules	1. Check whether the module power plug is plugged tightly;
		2. Replace the flat cable;
		3. Replace the power supply;
		4. Replace the module;

		5. Replace the receiving card;
5	All LED panels display the same content	1. Set the screen connection on software; 2. Check whether the data port is wrong.
6	No control system detected	1. Check the USB cable; 2. Check whether the computer USB port is malfunctioning; 3. Update the USB driver; 4. Replace the USB cable; 5. Replace the sending card;
7	No multi-function card detected	1. Check whether the distribution cabinet is in the automatic state; 2. Check whether the multi-function card is powered; 3. Replace the power supply of the multi-function card; 4. Check whether the main data cable is inserted into the wrong data port; 5. Check whether the sending card data port is malfunctioning; 6. Re-add the multi-function card; 7. Replace the multi-function card; 8. Replace the sending card;
8	No full screen display	1. Check whether the setting of the playback window is normal; 2. Check the output resolution of the video processor; 3. Check the output window of the video processor;

#### Check for Power Supply Short Circuit

After completing the cabinet wiring, please use a multimeter to check if there is any short circuit at the AC input power supply (L / N / PE) and DC output terminal (VCC / GND). If there is a short circuit, please carefully investigate the wiring. Make sure all wiring are normal, and only then connect power to operate the unit.