



Cyclorama Fixture

CYC175Q

USER MANUAL



For safety, please read this user manual carefully before initial use.

Event Lighting reserves the right to revise the manual at any time. Information and specifications within this manual are subject to change without notice. Event Lighting assumes no liability or responsibility for any errors or omissions. Please consult Event Lighting for any clarification or information regarding this item.

www.event-lighting.com.au

Ver 1.0

Table of contents

Caution!	3
Introduction	3
Safety instructions	3
Installation	4
Read 'Safety information' before installing the fixture.	4
Fastening the fixture to a flat surface	4
Mounting the fixture on a truss	4
Securing with a safety cable	5
DMX-512 connection/connection between fixtures	5
Power connection	6
Operation	6
Control Menu Map	6
Addressing	7
Universal DMX Control	8
RDM control	8
DMX Protocol	9
Fixture Cleaning	12
Troubleshooting	12
The fixture does not work, no light	12
Technical specifications	12

Caution!



Be careful with your operations. With a dangerous voltage you can suffer a dangerous electric shock when touching the wires!



Avoid looking directly into the light source!

Wear protective glasses and other PPE (personal protective equipment) when working on or near the fixture.



Always make sure you are connecting this product to the proper voltage in accordance with the specifications in this manual or on the product's specification label. Make sure it is grounded when using it!

Unplug mains lead before opening the housing!

Make sure that the power cord is never crimped or damaged by sharp edges. Check the fixture and the powercord from time to time.

Make sure to replace the fuse with another of the same type and rating.



For your own safety, please read this user manual carefully before you initial start-up.

Follow operating safety precautions and pay attention to warning signs methods and equipment on the user manual.



Warning! This symbol indicates a hot surface. Certain parts of the housing can become hot during operation. After use, wait for a cool-down period of at least 10 minutes before handling or transporting the device.



Indoor use only! To prevent risk of fire or shock, do not expose this product to rain or moisture. IP 20 rating.

T =45°C

The ambient temperature must always be between -5° C and +45° C.

Every person involved with the installation, operation and maintenance of this device has to

- be qualified
- follow the instructions of this manual
- consider this manual to be part of the total product
- keep this manual for the entire service life of the product
- pass this manual on to every further owner or user of the product
- download the latest version of the user manual from the Internet

Introduction

Thank you for having chosen CYC175Q. You will see you acquired a powerful and versatile device.

Unpack your item. Before you initial start-up, please make sure that there is no damage caused by transportation. Should there be any, consult your dealer and do not use the device.

Safety instructions

This device has left our premises in absolutely perfect condition. In order to maintain this condition and to ensure a safe operation, it is absolutely necessary for the user to follow the safety instructions and warning notes written in this user manual. Always disconnect from the mains, when the device is not in use or before cleaning it. Keep away children and amateurs from the device! There are no serviceable parts inside the device. Maintenance and service operations are only to be carried out by authorized dealers.

Installation

Read 'Safety information' before installing the fixture.

The fixture is designed for indoor use only and must be used in a dry location with adequate ventilation. Ensure that none of the fixture's ventilation slots are blocked.

Fasten the fixture to a secure structure or surface. Do not stand it on a surface or leave it where it can be moved or fall over. If you install the fixture in a location where it may cause injury or damage if it falls, secure it as directed in this user manual using a securely anchored safety cable that will hold the fixture if the primary fastening method fails.

Fastening the fixture to a flat surface

The fixture can be fastened to a hard, fixed, flat surface that is oriented at any angle. Ensure that the surface and all fasteners used can support at least 10 times the weight of all fixtures and equipment to be installed on it.

Fasten the fixture securely. Do not stand it on a surface or leave it where it can be moved or fall over. If you install the fixture in a location where it may cause injury or damage if it falls, secure it as directed below with a securely anchored safety cable that will hold the fixture if the primary fastening method fails.

Mounting the fixture on a truss

The fixture can be clamped to a truss or similar rigging structure in any orientation. When installing the fixture hanging vertically down, you can use an open-type clamp such as a G-clamp. When installing in any other orientation, you must use a half-coupler clamp that completely encircles the truss chord.

To clamp the fixture to a truss:

1. Check that the rigging structure can support at least 10 times the weight of all fixtures and equipment to be installed on it.
2. Block access under the work area.
3. Fold the legs of the mounting bracket together and bolt a rigging clamp securely to the mounting bracket. The bolt used must be M10, grade 8.8 steel minimum. It must pass through both mounting bracket legs and be fastened with a self-locking nut.
4. Working from a stable platform, hang the fixture with its clamp on the truss and fasten the clamp securely.
5. Secure the fixture with a safety cable as directed below.

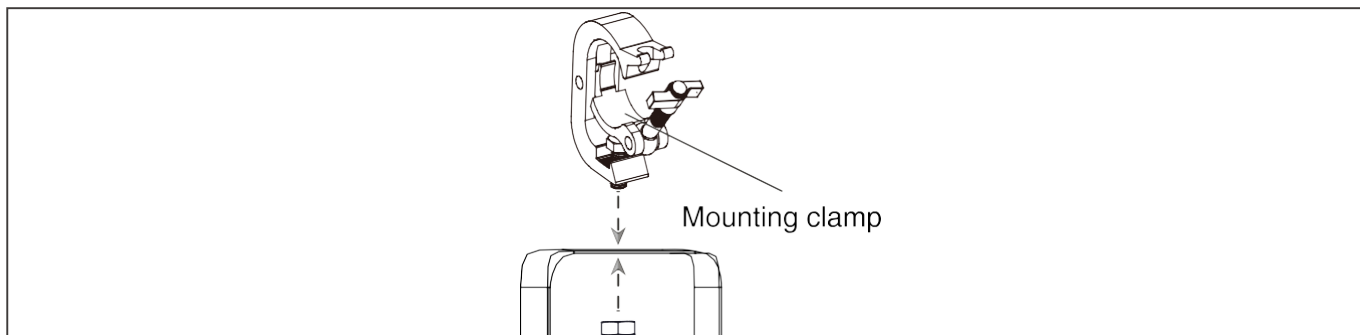

Securing with a safety cable

Secure the fixture with a safety cable (or other secondary attachment) that is approved for the weight of the fixture so that the safety cable will hold the fixture if a primary attachment fails.

Loop the safety cable through the eyebolt in the back of the fixture and around a secure anchoring point. Do not loop the safety cable around the fixture's mounting bracket only, as this will leave the fixture unsecured if it separates from the bracket.

DMX-512 connection/connection between fixtures

Occupation of the XLR-connection:

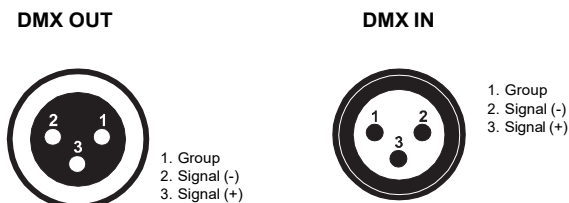

If you are using controllers with this occupation, you can connect the DMX-output of the controller directly with the DMX-input of the first fixture in the DMX-chain. If you wish to connect DMX-controllers with other XLR-outputs, you need to use adapter-cables.

Building a serial DMX-chain:

Connect the DMX-output of the first fixture in the DMX-chain with the DMX-input of the next fixture. Always connect one output with the input of the next fixture until all fixtures are connected.

DMX-512 connection with DMX terminator:

For installations where the DMX cable has to run a long distance or is in an electrically noisy environment, such as in a discotheque, it is recommended to use a DMX terminator. This helps in preventing corruption of the digital control signal by electrical noise. The DMX terminator is simply an XLR plug with a 120 resistor connected between pins 2 and 3, which is then plugged into the output XLR socket of the last fixture in the chain.

Caution: At the last fixture, the DMX-cable has to be terminated with a terminator. Solder a 120 Ω resistor between Signal (-) and Signal (+) into a 3-pin XLR-plug and plug it in the DMX-output of the last fixture.

Power connection

Power Requirements

The CYC175Q luminaire operates on 100 to 240 volts AC (+/- 10%, auto-ranging). The luminaire contains an auto-ranging power supply.

Power linking between fixtures:

The fixture with powercon in and out socket. Connect the power out to the power in socket in the next fixture till all are connected.

Caution: maximum power linking - 6 units.

Connection with the mains:

Connect the device to the mains with the enclosed power supply cable.

The occupation of the connection cables as below:

Cable color	Connection	International
Brown	Live	L
Blue	Neutral	N
Yellow/green	Earth(Ground)	

Operation

The CYC175Q zoom can operate in three different modes. This next section will detail the differences in the operating modes.

Control Menu Map

Default setting in **bold**.

MAIN MENU	LEVEL 1	LEVEL 2	LEVEL 3	FUNCTION INSTRUCTION
DMX	001-512			Set DMX address
Dimmer	DMX	2CH		Set DMX channel
		4CH		
		6CH		
		10CH		
	Auto	Program	1-4	Preset programs
		Speed	1-9	Preset programs speed, increasing
	Manu	Red	0-255	Red dimmer
		Green	0-255	Green dimmer
		Blue	0-255	Blue dimmer
		White	0-255	White dimmer
	Colo	3200K		Color marco
		5600K		
		Red		
Green				
Blue				

MAIN MENU	LEVEL 1	LEVEL 2	LEVEL 3	FUNCTION INSTRUCTION	
		White			
		Magenta			
		Seagreen			
		Orange			
		Skyblue			
		Plum			
		Gold			
Mode	Gamma	0.3-3.0		Dimmer curves set	
	Dimmer curves	Standard		Dimmer curve, Standard	
		Stage		Dimmer curve, Stage	
		TV		Dimmer curve, TV	
		Arch		Dimmer curve, Architecture	
		Theatre		Dimmer curve, Theatre	
		Studio		Power mode(less power, whisper fan)	
Advance	Signal hold	Yes/No		Signal hold switch	
	RDM	On/off		RDM function switch	
	ScreenT	30S/60S/Never		Display shut off time	
	LCD Reverse	Yes/No		Display reverse	
	Dim Freq	1.2K			Dimmer frequency select
		1.6K			
		2.4K			
		4.0K			
		6.0K			
		20.0K			
SoftVer	xxx			Software version	
Advanced-Men	Yes/No			Advanced settings/calibration(Only qualified technicians should perform this function. Inquire your local dealer for password.)	

Addressing

All fixtures should be given a DMX starting address when using a DMX signal, so that the correct fixture responds to the correct control signals. This digital starting address is the channel number from which the fixture starts to listen to the digital control information sent out from the DMX controller. The allocation of this starting address is achieved by setting the correct number on the display located on the base of the device.

You can set the same starting address for all fixtures or a group of fixtures, or make different address for each fixture individually.

If you set the same address, all the units will start to listen to the same control signal from the same

channel number. In other words, changing the settings of one channel will affect all the fixtures simultaneously.

If you set a different address, each unit will start to listen to the channel number you have set, based on the quantity of control channels of the unit. That means changing the settings of one channel will affect only the selected fixture.

In the case of the CYC175Q zoom, which is 2/4/6/10 channels fixture. If you set, for example, the address in the 2 channel mode to channel 3, the device will use the channel 3-4 for control.

Note: After switching on, the device will automatically detect whether DMX 512 data is received or not. If there is data received at the DMX input, you will see the DMX indicator light in green.

Universal DMX Control

This function allows you to use a universal DMX-512 controller to control the dimmer and strobe. A DMX controller allows you to create unique programs tailored to your individual needs.

RDM control

The CYC175Q can communicate using RDM (Remote Device Management) in accordance with ESTA's American National Standard E1.20-2006: Entertainment Technology RDM Remote Device Management Over DMX512 Networks.

RDM is a bi-directional communications protocol for use in DMX512 control systems, it is the open standard for DMX512 device configuration and status monitoring.

The RDM protocol allows data packets to be inserted into a DMX512 data stream without affecting existing non-RDM equipment. It allows a console or dedicated RDM controller to send commands to and receive messages from specific fixtures.

With RDM function, you can set the DMX address of your fixtures remotely. This is especially useful when the device is installed in a remote area.

Each CYC175Q has a factory set RDM UID (unique identification number).

Note: Before operation, enable RDM function in Advanced settings.

DMX Protocol

2-CH Mode	Function	Function Control
CH1	Dimmer	000-255: Dimmer
CH2	Color temperature	000-127: 3200K
		128-255: 5600K

4-CH Mode	Function	Function Control
CH1	Red	000-255: Red dimmer
CH2	Green	000-255: Green dimmer
CH3	Blue	000-255: Blue dimmer
CH4	White	000-255: White dimmer

6-CH Mode	Function	Function Control
CH1	Dimmer	000-255: Dimmer
CH2	Strobe	000-010: No function
		011-031: Level 1
		032-059: Level 2
		060-087: Level 3
		088-115: Level 4
		116-143: Level 5
		144-171: Level 6
		172-199: Level 7
		200-227: Level 8
228-255: Level 9		
CH3	Red	000-255: Red dimmer
CH4	Green	000-255: Green dimmer
CH5	Blue	000-255: Blue dimmer
CH6	White	000-255: White dimmer

10-CH Mode	Function	Function Control
CH1	Dimmer	000-255: Dimmer
CH2	Strobe	000-010: No function
		011-031: Level 1
		032-059: Level 2
		060-087: Level 3
		088-115: Level 4
		116-143: Level 5
		144-171: Level 6
		172-199: Level 7
		200-227: Level 8
		228-255: Level 9
CH3	Red	000-255: Red dimmer
CH4	Green	000-255: Green dimmer
CH5	Blue	000-255: Blue dimmer
CH6	White	000-255: White dimmer
CH7	Color temperature	000-127: 3200K
		128-255: 5600K
CH8	Color marco	000-016: No function
		017-025: Floral White
		026-035: Lemon Chiffon
		036-045: Seashell
		046-055: Honeydew
		056-065: Skyblue
		066-075: Dark Turquoise
		076-085: Aquamarine
		086-095: Spring Green
		096-105: Gold
		106-115: Indian Red
		116-125: Salmon
		126-135: Orange Red
		136-145: LightPink
		146-155: Violet
156-165: Purple		

10-CH Mode	Function	Function Control
		166-175: Honeydew 176-185: Steel Blue 186-195: Cyan 196-205: Sea Green 206-215: Khaki 216-225: Brown 226-235: Pink 236-245: Violet Red 246-255: Medium Purple
CH9	Color switching	000-015: No function 016-075: Rainbow fading 076-135: Rainbow jumping 136-195: Warmwhite fading 196-255: Coldwhite fading
CH10	Color switching speed	000-010: No function 011-031: Level 1 032-059: Level 2 060-087: Level 3 088-115: Level 4 116-143: Level 5 144-171: Level 6 172-199: Level 7 200-227: Level 8 228-255: Level 9

Fixture Cleaning

Due to fog residue, smoke, and dust cleaning the internal and external optical lenses and mirror should be carried out periodically to optimize light output. Cleaning frequency depends on the environment in which the fixture operates (i.e. smoke, fog residue, dust, dew). In heavy club use we recommend cleaning on a monthly basis. Periodic cleaning will ensure longevity, and crisp output.

To clean the fixture:

1. Disconnect the fixture from power and allow it to cool for at least 10 minutes.
2. Vacuum or gently blow away dust and loose particles from the outside of the fixture with low-pressure compressed air.
3. Clean the surfaces by wiping gently with a soft, clean lint-free cloth moistened with a weak detergent solution. Do not rub glass surfaces hard: lift particles off with a soft repeated press. Dry with a soft, clean, lint-free cloth or low-pressure compressed air. Remove stuck particles with an unscented tissue or cotton swab moistened with glass cleaner or distilled water.
4. Check that the fixture is dry before reapplying power.

Troubleshooting

Listed below are a few common problems that you may encounter, with solutions.

The fixture does not work, no light

- Check the connection of power and main fuse. Be sure the external fuse has not blown.
- Measure the mains voltage on the main connector.

Technical specifications

Model	CYC175Q
Power supply:	AC100 - 240V, 50/60Hz
Light source:	200Watt COB LED
Color mixing:	RGBW
Power consumption:	175Watt
Color temperature:	3200K - 5600K optional
Power connection:	PowerCON in & out
Signal connection:	3-pin XLR in & out
DMX channels:	2/4/6/10
Control protocol:	DMX, RDM, Auto program
Housing:	Colour black, aluminum
Size:	193 x 190 x 266mm(7.6 x 7.5 x 10.5in)
N.W.:	2.7kg(5.9lb)
Environment:	IP20

WARRANTY

Please refer to your local dealer or please contact Event Lighting Pty Ltd
Website: www.event-lighting.com.au.