

# EVENT LIGHTING

## DELUGEM7X60WFX

LED 7x60W Wash Moving Head IP65(RGBW)

## USER MANUAL



**For safety, please read this user manual carefully before initial use.**

Event Lighting reserves the right to revise the manual at any time. Information and specifications within this manual are subject to change without notice. Event Lighting assumes no liability or responsibility for any errors or omissions. Please consult Event Lighting for any clarification or information regarding this item.

Version: 1 (14 September 2023)

## SAFETY PRECAUTIONS

This fixture is a sophisticated piece of electronic equipment. To guarantee a smooth operation, it is important to follow all instructions and guidelines in this manual. Professional is not responsible for injuries and/or damages resulting from the misuse of this fixture due to the disregard of the information printed in this manual. Only qualified and/or certified personnel should perform installation of this fixture and only the original rigging parts included with this fixture should be used for installation. Any modifications to the fixture and/or the included mounting hardware will void the original manufacturer's warranty and increase the risk of damage and/or personal injury.



**PROTECTION CLASS 1 - FIXTURE MUST BE PROPERLY GROUNDED.**



**THERE ARE NO USER SERVICEABLE PARTS INSIDE THIS UNIT. DO NOT ATTEMPT ANY REPAIRS YOURSELF, AS DOING SO WILL VOID YOUR MANUFACTURER'S WARRANTY. DAMAGES RESULTING FROM MODIFICATIONS TO THIS FIXTURE AND/OR THE DISREGARD OF SAFETY INSTRUCTIONS AND GUIDELINES IN THIS MANUAL VOID THE MANUFACTURER'S WARRANTY AND ARE NOT SUBJECT TO ANY WARRANTY CLAIMS AND/OR REPAIRS.**



**DO NOT PLUG FIXTURE INTO A DIMMER PACK!  
NEVER OPEN THIS FIXTURE WHILE IN USE!  
UNPLUG POWER BEFORE SERVICING FIXTURE!  
NEVER TOUCH FIXTURE DURING OPERATION, AS IT MAY BE HOT! KEEP FLAMMABLE MATERIALS AWAY FROM FIXTURE!**



**NEVER LOOK DIRECTLY INTO THE LIGHT SOURCE!  
RETINA INJURY RISK - MAY INDUCE BLINDNESS!  
SENSITIVE PERSONS MAY SUFFER AN EPILEPTIC SHOCK!**



**ENSURE ALL CONNECTIONS AND END CAPS ARE PROPERLY SEALED WITH A DIELECTRIC GREASE (AVAILABLE AT MOST ELECTRICAL SUPPLIERS) TO PREVENT WATER CORROSION AND/OR ELECTRICAL SHORT CIRCUIT.**



**MINIMUM DISTANCE TO OBJECTS/SURFACES  
MUST BE 3.3 FEET (1 METER)  
MAXIMUM TEMP OF EXTERNAL SURFACE 185° F (85° C)  
MINIMUM DISTANCE OF FLAMMABLE MATERIALS FROM THE SURFACE IS  
1.6 FEET (0.5 METER)**

## **SAFETY PRECAUTIONS**

- DO NOT TOUCH the fixture housing during operation. Turn OFF the power and allow approximately 15 minutes for the fixture to cool down before servicing.
- DO NOT shake fixture, and avoid brute force when installing and/or operating fixture.
- DO NOT operate fixture if the power cord is frayed, crimped, damaged and/or if any of the power cord connectors are damaged and do not insert into the fixture securely with ease.
- NEVER force a power cord connector into the fixture. If the power cord or any of its connectors are damaged, replace it immediately with a new one of the same power rating.
- DO NOT block any air ventilation slots.
- All fan and air inlets must remain clean and never blocked.
- Allow approx. 6" (15cm) between fixture and other devices or a wall for proper cooling.
- Always disconnect fixture from main power source before performing any type of service and/or cleaning procedure.
- Only handle the power cord by the plug end. Never pull out the plug by tugging the wire portion of the cord.
- During the initial operation of this fixture, a light smoke or smell may emit from the interior of the fixture. This is a normal process and is caused by excess paint in the interior of the casing burning off from the heat associated with the lamp and will decrease gradually over time.
- Consistent operational breaks will ensure fixture will function properly for many years .
- ONLY use the original packaging and materials to transport the fixture in for service.

# MAINTENANCE GUIDELINES



**DISCONNECT POWER BEFORE PERFORMING ANY MAINTENANCE!**

## CLEANING

Frequent cleaning is recommended to ensure proper function, optimized light output, and an extended life. The frequency of cleaning depends on the environment in which the fixture operates: damp, smoky or particularly dirty environments can cause greater accumulation of dirt on the fixture's optics. Periodically clean the external lens surface with a soft cloth to avoid dirt/debris accumulation. **NEVER** use alcohol, solvents, or ammonia-based cleaners .

## MAINTENANCE

Regular inspections are recommended to ensure proper function and extended life. There are no user serviceable parts inside this fixture. Please refer all other service issues to an authorized our service technician. Should you need any spare parts, please order genuine parts from your local dealer.

Please refer to the following points during routine inspections:

- A detailed electric check by an approved electrical engineer every three months, to make sure the circuit contacts are in good condition and prevent overheating.
- Be sure all screws and fasteners are securely tightened at all times. Loose screws may fall out during normal operation, resulting in damage or injury as larger parts could fall.
- Check for any deformations on the housing, color lenses, rigging hardware, and rigging points (ceiling, suspension, trussing). Deformations in the housing could allow for dust to enter into the fixture. Damaged rigging points or unsecured rigging could cause the fixture to fall and seriously injure a person(s).
- Electric power supply cables must not show any damage, material fatigue or sediments. **NEVER** remove the ground prong from the power cable.

# OVERVIEW

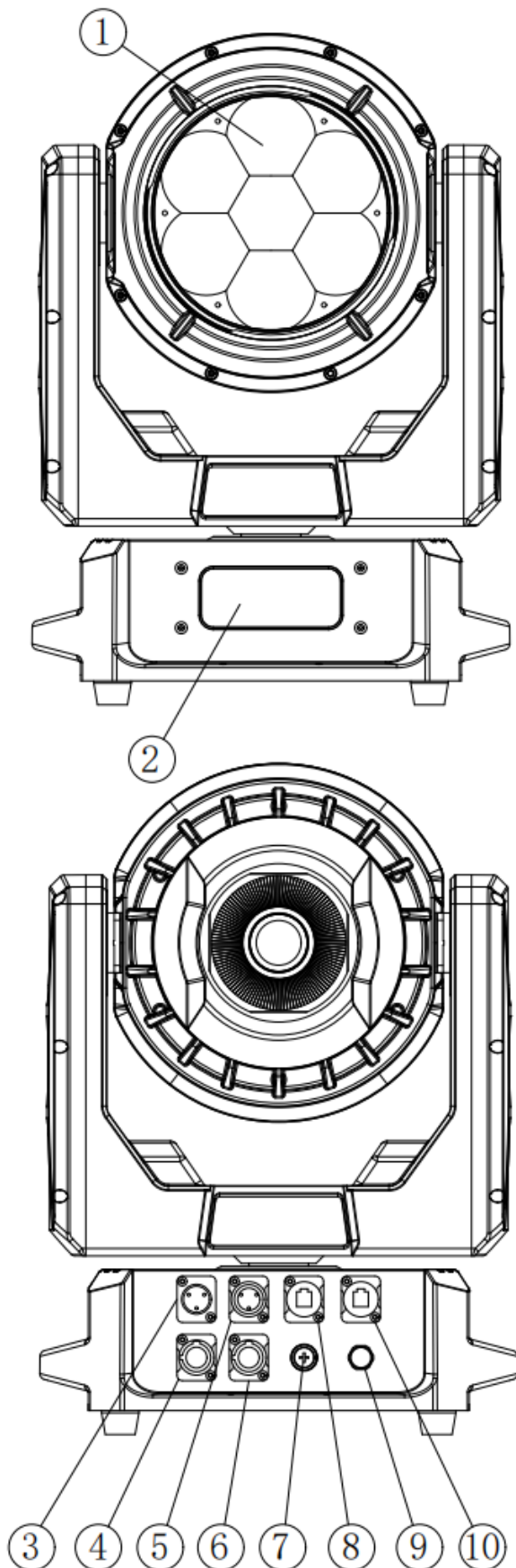

**1. Lens**

**2. System Menu LCD**

**Display**

**3. DMX Input**

**4. Power Input**

**5. DMX Output**

**6. Power Output**

**7. Fuse**

**8. RJ45 Input**

**9. Value**

**10. RJ45 Output**

# INSTALLATION GUIDELINES



## FLAMMABLE MATERIAL WARNING

Keep fixture minimum 5.0 feet (1.5m) away from flammable materials and/or pyrotechnics.



## ELECTRICAL CONNECTIONS

A qualified electrician should be used for all electrical connections and/or installations.



**MINIMUM DISTANCE TO SURFACES/OBJECTS IS 3.3 FEET (1 METER).**

**MINIMUM DISTANCE TO FLAMMABLE MATERIALS IS 1.6 FEET (0.5 METER).**

**EXTERNAL SURFACE CAN REACH TEMPERATURES OF 185° F (85° C).**



**DO NOT INSTALL THE FIXTURE IF YOU ARE NOT QUALIFIED TO DO SO!**

Fixture **MUST** be installed following all local, national, and country commercial electrical and construction codes and regulations.

Before rigging/mounting a single fixture or multiple fixtures to any metal truss/structure or placing the fixture(s) on any surface, a professional equipment installer **MUST** be consulted to determine if the metal truss/structure or surface is properly certified to safely hold the combined weight of the fixture(s), clamps, cables, and accessories.

Overhead rigging requires extensive experience, including calculating working load limits, installation material being used, and periodic safety inspection of all installation material and the fixture, among other skills. If you lack these qualifications, do not attempt the installation yourself. Improper installation can result in bodily injury.

Fixture ambient operating temperature range is -4° to 113°F (-20° to 45°C). Do not operate the fixture when the ambient temperature falls outside of this range.

Fixture(s) should be installed away from walking paths, seating areas, or areas where unauthorized personnel might reach the fixture by hand.

**NEVER** stand directly below the fixture(s) when rigging, removing, or servicing.

Overhead fixture installation must always be secured with a secondary safety attachment, such as an appropriately rated safety cable.

Allow approximately 15 minutes for the fixture to cool down before serving.

# INSTALLATION GUIDELINES

## OMEGA BRACKET INSTALLATION

Insert the Omega Brackets into the matching holes on the bottom of the fixture. Secure the Omega Brackets to the fixture by turning each quick-lock fastener  $\frac{1}{4}$  turn clockwise . **Always check to make sure that each fastener is completely locked.** Omega brackets can be installed into the underside of the fixture's base as illustrated below.

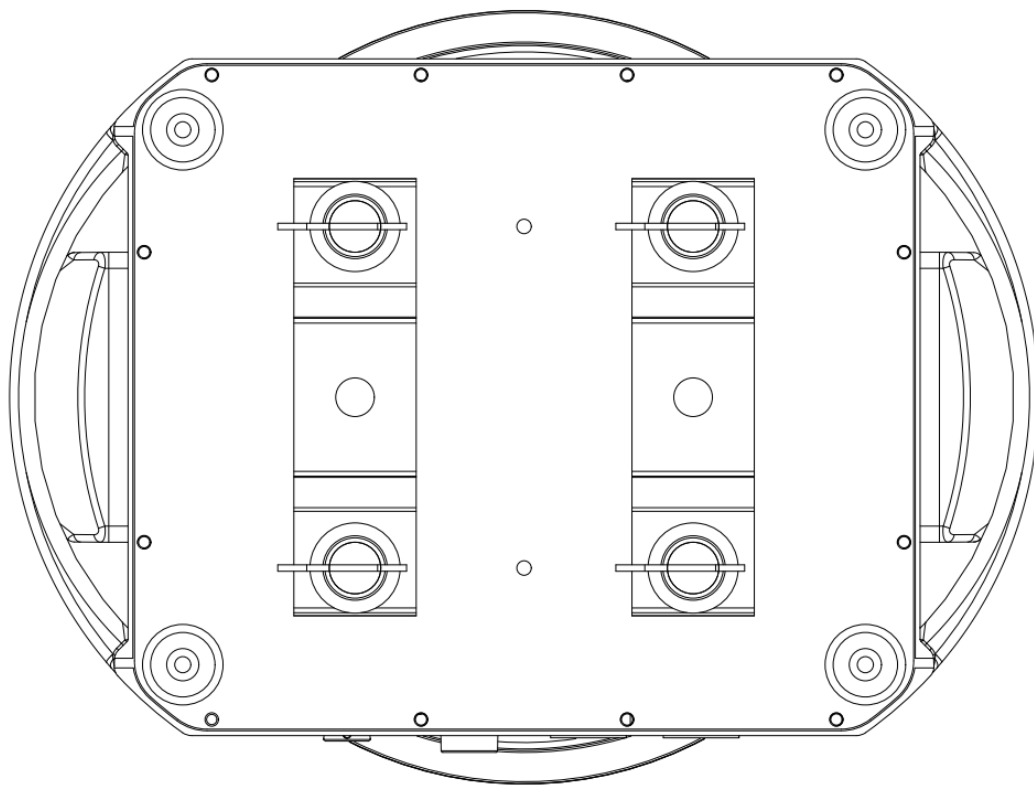

## CLAMP INSTALLATION

When mounting the fixture to a truss, be sure to secure appropriately rated professional grade rigging clamps to the included Omega Brackets using an M10 screw fitted through the center hole of the Omega Brackets. This fixture requires the installation of two Omega brackets and two clamps for secure truss mounting. The fixture also provides built-in rigging points for a SAFETY CABLE. Be sure to only use the designated rigging point for the safety cable and never secure a safety cable to a carrying handle.

### SAFETY CABLE:

**ALWAYS ATTACH A SAFETY CABLE WHENEVER INSTALLING THIS FIXTURE IN A SUSPENDED ENVIRONMENT TO ENSURE THAT THE FIXTURE WILL NOT FALL IF THE CLAMP FAILS.**





# INSTALLATION GUIDELINES

## POWER AND DATA CABLES



TO MAINTAIN THE IP65 RATING INTEGRITY OF THE FIXTURE, ALL CABLES MUST BE RUN TOWARDS THE GROUND IN ORDER TO PREVENT WATER ACCUMULATION AROUND THE CONNECTIONS.

### SYSTEM MENU

### LCD DISPLAY

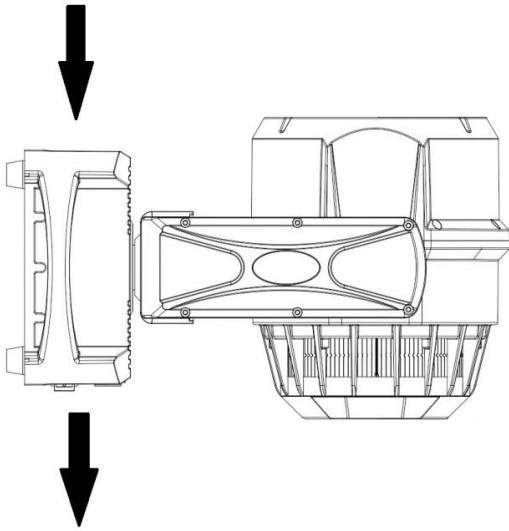

CABLES

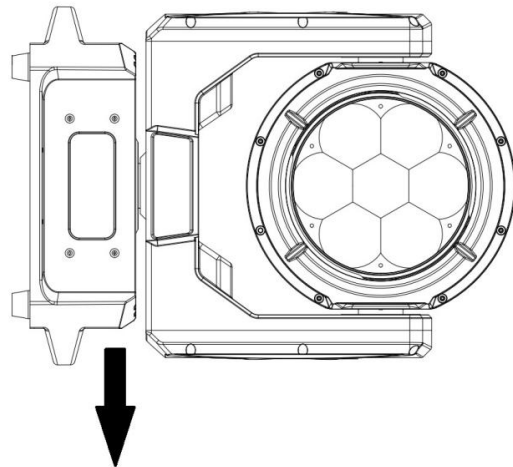

CABLES

## RJ45 DATA CABLES



THE INCLUDED RJ45 DATA CABLE IS FOR FIXTURE TO FIXTURE INTERCONNECTIONS ONLY! THE RJ45 CABLE CONNECTORS MAY NOT BE COMPATIBLE WITH OTHER RJ45 OR ETHERNET TYPE CONNECTORS.

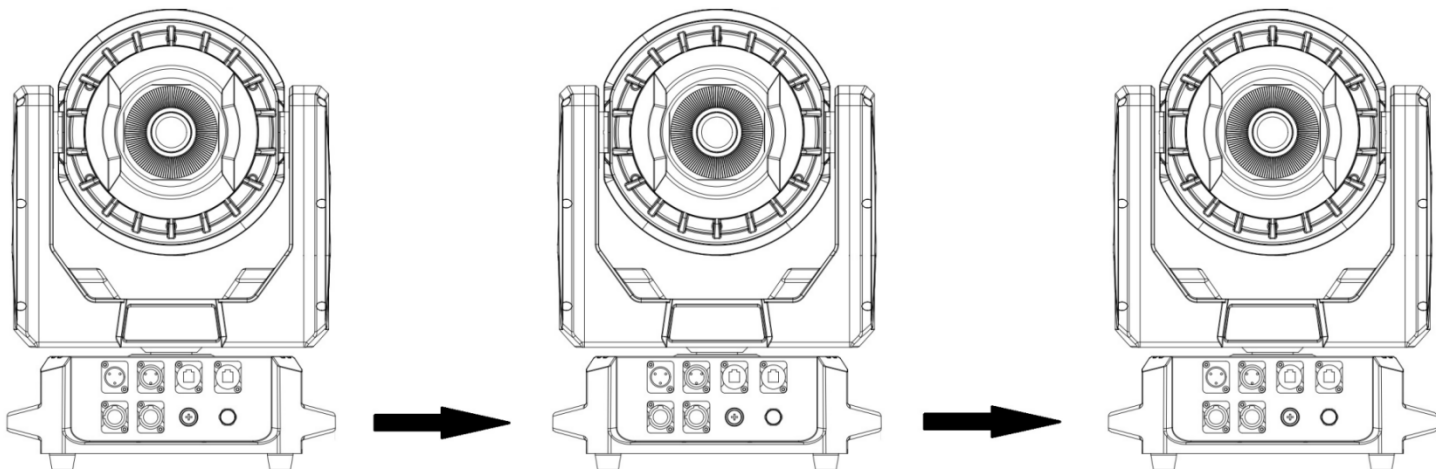



# INSTALLATION GUIDELINES

## POWER AND DATA CONNECTIONS



ENSURE ALL CONNECTIONS AND END CAPS ARE PROPERLY SEALED WITH A DIELECTRIC GREASE (AVAILABLE AT MOST ELECTRICAL SUPPLIERS) IN ORDER TO PREVENT WATER CORROSION AND/ OR ELECTRICAL SHORT CIRCUIT.



TO MAINTAIN IP65 RATING INTEGRITY AND PREVENT WATER FROM ENTERING THE FIXTURE, SEAL ALL UNUSED CONNECTION RUBBER CAPS.

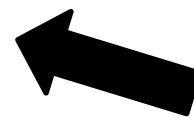
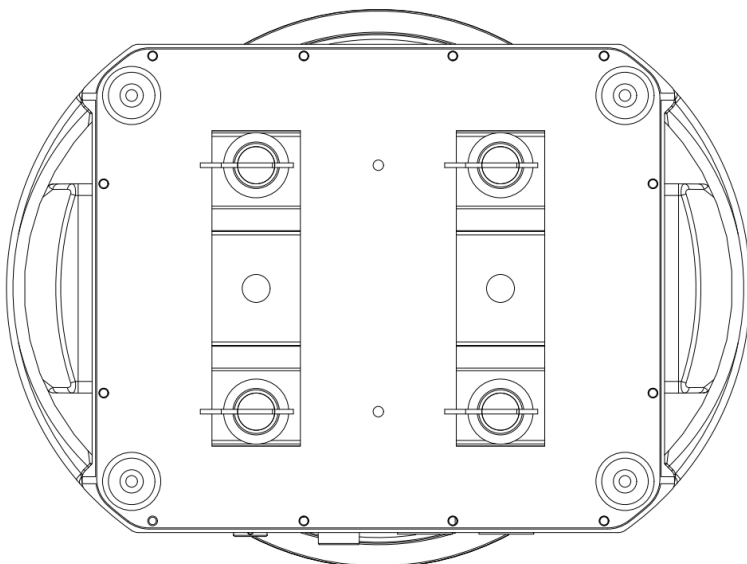
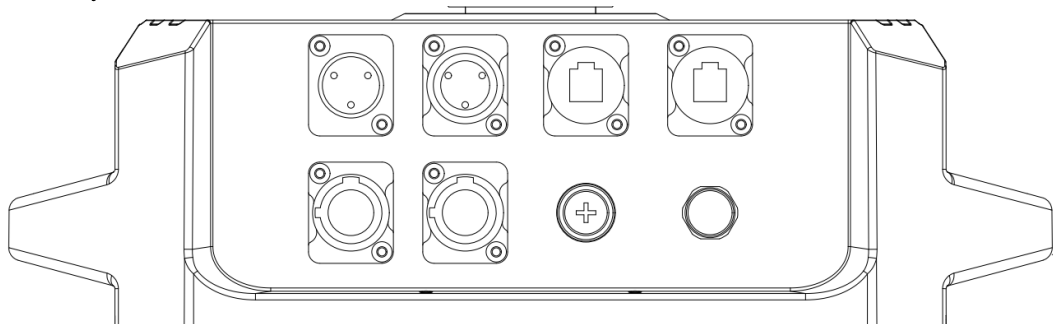

**SAFETY  
CABLE  
LOOP**



**ALWAYS ATTACH A SAFETY CABLE WHENEVER INSTALLING THIS DEVICE IN A SUSPENDED ENVIRONMENT TO ENSURE THE FIXTURE WILL NOT FALL IF THE CLAMP FAILS !**

# SYSTEM MENU

Main Menu	Sub Menu	Option/Value	Option/Value	
Address	001			
	...			
	512			
Channel	028CH			
	049CH			
	105CH			
	127CH			
Setting	Control Mode	DMX		
		Artnet		
		DMX+Artnet		
		sACN		
		DMX+sACN		
	Dimmer Mode	Linear		
		Square		
		I-Square		
		S-Shape		
	Dimmer Speed	Slow		
		Fast		
	LED Frequency	400HZ		
		1200HZ		
		2000HZ		
		4000HZ		
		6000HZ		
		8000HZ		
		16000HZ		
	24000HZ			
	White Balance	R	000-255	
		G	000-255	
		B	000-255	
		W	000-255	
	FAN Mode	Auto		
		Silent		
		Full		
	Calibration	Invert_Pan	NO/YES	
		Invert_Tilt	NO/YES	
		System Calibration	PAN 001~255	
			Tilt 001~255	
			Focus 001~255	
	Rotate 001~255			
Language	Chinese			
	English			
Invert Screen	OFF			
	ON			

		AUTO	
	Signal Keep	NO/YES	
	Screen Lock	NO/YES	
	Load Default	NO.YES	
Network	Internet	IP	002.000.000.001
		MS	255.000.000.000
	Universe	Net(0~127)	000~127
		Sub Universe	000~127
Manual	Pan	000~255	
	Tile	000~255	
	Zoom	000~255	
	Rotation	000~255	
	Red	000~255	
	Green	000~255	
	Blue	000~255	
	White	000~255	
	Spark Red	000~255	
	Spark Green	000~255	
	Spark Blue	000~255	
	Effect	000~255	
	Spark Effect	000~255	
	Reset	Reset Effect	
Reset Scan			
Rest All			

# LIGHTING CONSOLE PATCHING GUIDELINES

The product is a versatile luminaire which combines two fixtures into one housing, allowing it to produce multiple unique lighting effects typically not found in a single lighting fixture. The DMX layout is designed to offer a variety of options for controlling each fixture efficiently.

The main fixture contains 7x 60W RGBW LEDs, while the Aura effects contains 28x0.5W RGB LEDs. For ease of use the DMX layout is arranged to allow lighting consoles to separate the fixture into multiple segments or parts. It is especially important to arrange the fixture in such segments or parts when using the fixture in the full extended 127channel DMX mode. For simpler programming, reduced DMX channel modes can be used. However, for easy recall of interesting pixel animations, both the RGBW and Aura LED fixtures contain two FX systems: one which controls the RGBW cells, and a second that is dedicated to the Aura LEDs.

The pixels are arranged in a grid pattern as illustrated below. ( RGBW 1-7 / Aura LED 8-35)

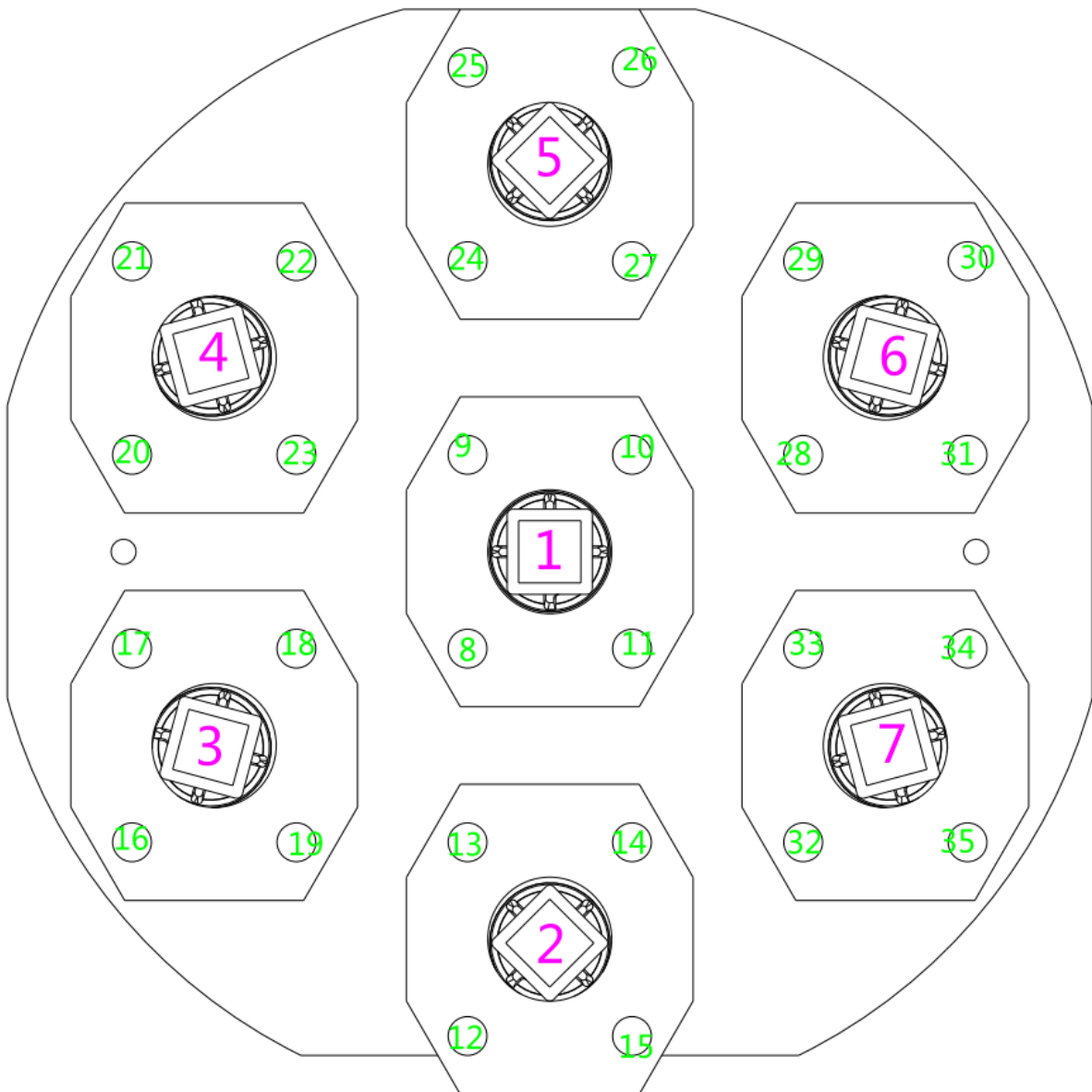

# DMX CHART

## 28CH Mode(DMX,ArtNet,sACN)

Channel	Value	Function	Description
1CH	0-255	Pan Movement	0°- 540°
2CH	0-255	Fine Pan Movement positioning	16 bit adjustable
3CH	0-255	Tilt Movement	0°- 205°
4CH	0-255	Fine Tilt Movement positioning	16 bit adjustable
5CH	0-255	Pan/tilt Speed	fast to slow
6CH	0-255	Shutter	
	0-5	/	
	6-55	Synchronous strobe	From slow to fast
	56-105	Pulse strobe	From slow to fast
	106-155	Random strobe	From slow to fast
	156-205	Fade Strobe1	From slow to fast Brightness from high to low
	206-255	Fade Strobe2	From slow to fast Brightness from low to high
7CH	0-255	Dimmer	Linear 0-100%
8CH	0-255	Fine Dimmer	Linear 0-100%
9CH	0-255	60W LED - RED	0-100%
10CH	0-255	60W LED - GREEN	0-100%
11CH	0-255	60W LED - BLUE	0-100%
12CH	0-255	60W LED - WHITE	0-100%
13CH	0-255	Zoom	3.15°- 45° (From narrow to wide )
14CH	0-255	Reset	
	0-200	/	
	201-215	Zoom/lens-rotation motors reset	The value stops for 5 seconds
	216-230	P/T motors reset	The value stops for 5 seconds
	231-245	Overall reset	The value stops for 5 seconds
	246-255	/	
15CH	0-255	Movement Macro	
	0-9	/	
	10-39	Program 1	~
	40-69	Program 2	~
	70-99	Program 3	~
	100-139	Program 4	~
	140-169	Program 5	~
	170-229	Program 6	~
230-255	Program 7	~	
16CH	0-255	Move Speed/Sensitivity	/

	0-128	From right to left position (0-360°)	Slow to fast
	129-255	From left to right position (0-360°)	Fast to slow
17CH	0-255	Preset Colours	
	0-45		
	46-50	Cyan	R=000,G=255,B=255,W=000
	51-55	Yellow	R=255,G=255,B=000,W=000
	56-60	Magenta	R=255,G=000,B=255,W=000
	61-65	Medium Yellow	R=156,G=126,B=000,W=000
	66-70	Straw Tint	R=152,G=115,B=009,W=000
	71-75	Surprise Peach	R=198,G=114,B=009,W=000
	76-80	Fire	R=255,G=056,B=000,W=000
	81-85	Medium Amber	R=255,G=135,B=000,W=000
	86-90	Gold Amber	R=255,G=100,B=000,W=000
	91-95	Dark Amber	R=255,G=065,B=000,W=000
	96-100	Sunrise Red	R=255,G=083,B=002,W=000
	101-105	Light Pink	R=255,G=112,B=000,W=141
	106-110	Medium Pink	R=255,G=087,B=000,W=107
	111-115	Pink Carnation	R=255,G=107,B=000,W=130
	116-120	Light Lavender	R=243,G=117,B=039,W=197
	121-125	Sky Blue	R=000,G=255,B=135,W=000
	126-130	Just Blue	R=000,G=194,B=130,W=000
	131-135	Dark yellow green	R=041,G=219,B=000,W=000
	136-140	Spring Yellow	R=245,G=202,B=000,W=000
	141-145	Light Amber	R=237,G=163,B=000,W=000
	146-150	Straw Tint	R=230,G=160,B=000,W=069
	151-155	Deep Amber	R=255,G=166,B=000,W=000
	156-160	Orange	R=255,G=122,B=000,W=000
	161-165	Light Rose	R=255,G=141,B=031,W=000
	166-170	Middle Rose	R=217,G=130,B=028,W=000
	171-175	Dark Pink	R=255,G=109,B=033,W=000
	176-180	Magenta	R=255,G=020,B=015,W=000
	181-185	Peacock Blue	R=051,G=255,B=051,W=000
	186-190	Steel Blue	R=206,G=255,B=056,W=000
	191-195	Light Blue	R=074,G=255,B=082,W=000
196-200	Dark Blue	R=000,G=186,B=255,W=000	
201-205	Leaf Green	R=206,G=255,B=000,W=000	
206-210	Dark Green	R=084,G=255,B=013,W=000	
211-215	Mauve	R=227,G=041,B=056,W=000	
216-220	Deep Golden Amber	R=255,G=058,B=000,W=000	
221-225	Pale Lavender	R=255,G=197,B=061,W=000	
226-230	Primary Green	R=077,G=255,B=000,W=000	
231-235	Bright Blue	R=000,G=255,B=087,W=000	
235-240	Apricot	R=255,G=143,B=013,W=000	

	241-245	Pale Gold	R=253,G=171,B=026,W=000
	246-250	Deep Orange	R=222,G=084,B=000,W=000
	251-255	Flame Red	R=255,G=046,B=002,W=000
18CH	0-255	Preset CTO	Color temperature 2000K-8000K
	0-17	Off light	
	18-34	8000K	R=255,G=182,B=110,W=255
	35-51	7500K	R=255,G=144,B=089,W=255
	52-68	6500K	R=255,G=129,B=081,W=255
	69-85	6000K	R=255,G=121,B=073,W=255
	86-102	5600K	R=255,G=106,B=066,W=255
	103-119	5000K	R=255,G=090,B=055,W=255
	120-136	4500K	R=255,G=071,B=043,W=255
	137-153	4000K	R=255,G=055,B=034,W=255
	154-170	3500K	R=255,G=029,B=024,W=255
	171-187	3200K	R=255,G=011,B=019,W=255
	188-204	3000K	R=255,G=004,B=016,W=255
	205-221	2700K	R=255,G=000,B=009,W=203
	222-238	2500K	R=255,G=000,B=004,W=172
	239-255	2000K	R=255,G=000,B=000,W=105
19CH	0-255	Pixel Macro 60W	Linear 0-100%
	0-5	/	Program1-program16
	6-20	Program 1	
	21-35	Program 2	The color-changes of the build-in effects of 60w Leds is controlled by its color CH
	36-50	Program 3	~
	51-65	Program 4	~
	66-80	Program 5	~
	81-95	Program 6	~
	96-110	Program 7	~
	111-125	Program 8	~
	126-140	Program 9	~
	141-155	Program 10	~
	156-170	Program 11	~
	171-185	Program 12	~
	186-200	Program 13	~
	201-215	Program 14	~
	216-230	Program 15	~
231-245	Program 16	~	
246-255	Auto-running Pixel Macro 60W	~	
20CH	0-255	Pixel Macro Speed	Linear 0-100%
21CH	0-255	Lens Rotation	
	0-5	/	
	6-62	Lens Rotation 1	
	63-127	Lens Rotation 2	From left to right position (0-360°)



	128-192	Lens Rotation 3	From right to left position (0-360°)
	193-255	Lens Rotation 4	From left to right position (Infinite-Rotation) From slow to fast
22CH	0-255	SMD Shutter	
	0-5	/	
	6-55	Synchronous strobe	From slow to fast
	56-105	Pulse strobe	From slow to fast
	106-155	Random strobe	From slow to fast
	156-205	Fade Strobe1	From slow to fast Brightness from high to low
	206-255	Fade Strobe1	From slow to fast Brightness from low to high
23CH	0-255	SMD Dimmer	0-100%
24CH	0-255	SMD Red	Linear 0-100%
25CH	0-255	SMD Green	Linear 0-100%
26CH	0-255	SMD Blue	Linear 0-100%
27CH	0-255	SMD Macro	From Slow to fast
	0-5	/	Program1-program16
	6-20	Program 1	
	21-35	Program 2	The color-changes of the SMD Macro is controlled by its color CH
	36-50	Program 3	~
	51-65	Program 4	~
	66-80	Program 5	~
	81-95	Program 6	~
	96-110	Program 7	~
	111-125	Program 8	~
	126-140	Program 9	~
	141-155	Program 10	~
	156-170	Program 11	~
	171-185	Program 12	~
	186-200	Program 13	~
	201-215	Program 14	~
	216-230	Program 15	~
231-245	Program 16	~	
246-255	Auto-running SMD Macro	~	
28CH	0-255	SMD Macro Speed	Program 1-Program 16 Auto-running

**49CH Mode ( Support Dmx /Artnet/sACN. When u use DMX+Artnet mode, the 1-17CH are controlled by DMX protocol)**

Channel	Value	Function	Description
1CH	0-255	Pan Movement	0°- 540°
2CH	0-255	Fine Pan Movement positioning	16 bit adjustable
3CH	0-255	Tilt Movement	0° - 205°
4CH	0-255	Fine Tile Movement positioning	16 bit adjustable
5CH	0-255	Pan/Tilt Speed	fast to slow
6CH	0-255	Zoom	3.15° - 45° (From narrow to wide )
7CH	0-255	Fine Zoom positioning	
8CH	0-255	Lens Rotation	
	0-5	/	
	6-62	Lens Rotation 1	From left to right position (0-360°)
	63-127	Lens Rotation 2	From right to left position (0-360°)
	128-192	Lens Rotation 3	From left to right position (Infinite-Rotation) From slow to fast
	193-255	Lens Rotation 4	From right to left position (Infinite-Rotation) From slow to fast
9CH	0-255	Reset	
	0-200	/	
	201-215	Zoom/lens-rotation motors reset	The value stops for 5 seconds
	216-230	P/T motors reset	The value stops for 5 seconds
	231-245	Overall reset	The value stops for 5 seconds
	246-255	/	
10CH	0-255	SMD Dimmer	Linear 0-100%
11CH	0-255	Fine SMD Dimmer	
12CH	0-255	SMD Shutter	
	0-5	/	
	6-55	Synchronous strobe	From slow to fast
	56-105	Pulse strobe	From slow to fast
	106-155	Random strobe	From slow to fast
	156-205	Fade Strobe1	From slow to fast Brightness from high to low
	206-255	Fade Strobe1	From slow to fast Brightness from low to high
13CH	0-255	SMD Red	Linear 0-100%
14CH	0-255	SMD Green	Linear 0-100%
15CH	0-255	SMD Blue	Linear 0-100%
16CH	0-255	SMD Macro	Program1-program16
	0-5	/	
	6-20	Program 1	The color-changes of the SMD Marco is

			controlled by its color CH
	21-35	Program 2	~
	36-50	Program 3	~
	51-65	Program 4	~
	66-80	Program 5	~
	81-95	Program 6	~
	96-110	Program 7	~
	111-125	Program 8	~
	126-140	Program 9	~
	141-155	Program 10	~
	156-170	Program 11	~
	171-185	Program 12	~
	186-200	Program 13	~
	201-215	Program 14	~
	216-230	Program 15	~
	231-245	Program 16	~
	246-255	Auto-running SMD Marco	Program 1-Program 16 Auto-running
17CH	0-255	SMD Marco Speed	from slow to fast
18CH	0-255	Dimmer	0-100%
19CH	0-255	Shutter	
	0-5	/	
	6-55	Synchronous strobe	From slow to fast
	56-105	Pulse strobe	From slow to fast
	106-155	Random strobe	From slow to fast
	156-205	Fade Strobe1	From slow to fast Brightness from high to low
	206-255	Fade Strobe2	From slow to fast Brightness from low to high
20CH	0-255	Preset Colours	
	0-45		
	46-50	Cyan	R=000,G=255,B=255,W=000
	51-55	Yellow	R=255,G=255,B=000,W=000
	56-60	Magenta	R=255,G=000,B=255,W=000
	61-65	Medium Yellow	R=156,G=126,B=000,W=000
	66-70	Straw Tint	R=152,G=115,B=009,W=000
	71-75	Surprise Peach	R=198,G=114,B=009,W=000
	76-80	Fire	R=255,G=056,B=000,W=000
	81-85	Medium Amber	R=255,G=135,B=000,W=000
	86-90	Gold Amber	R=255,G=100,B=000,W=000
	91-95	Dark Amber	R=255,G=065,B=000,W=000
	96-100	Sunrise Red	R=255,G=083,B=002,W=000
	101-105	Light Pink	R=255,G=112,B=000,W=141
	106-110	Medium Pink	R=255,G=087,B=000,W=107
	111-115	Pink Carnation	R=255,G=107,B=000,W=130
116-120	Light Lavender	R=243,G=117,B=039,W=197	

	121-125	Sky Blue	R=000,G=255,B=135,W=000
	126-130	Just Blue	R=000,G=194,B=130,W=000
	131-135	Dark yellow green	R=041,G=219,B=000,W=000
	136-140	Spring Yellow	R=245,G=202,B=000,W=000
	141-145	Light Amber	R=237,G=163,B=000,W=000
	146-150	Straw Tint	R=230,G=160,B=000,W=069
	151-155	Deep Amber	R=255,G=166,B=000,W=000
	156-160	Orange	R=255,G=122,B=000,W=000
	161-165	Light Rose	R=255,G=141,B=031,W=000
	166-170	Middle Rose	R=217,G=130,B=028,W=000
	171-175	Dark Pink	R=255,G=109,B=033,W=000
	176-180	Magenta	R=255,G=020,B=015,W=000
	181-185	Peacock Blue	R=051,G=255,B=051,W=000
	186-190	Steel Blue	R=206,G=255,B=056,W=000
	191-195	Light Blue	R=074,G=255,B=082,W=000
	196-200	Dark Blue	R=000,G=186,B=255,W=000
	201-205	Leaf Green	R=206,G=255,B=000,W=000
	206-210	Dark Green	R=084,G=255,B=013,W=000
	211-215	Mauve	R=227,G=041,B=056,W=000
	216-220	Deep Golden Amber	R=255,G=058,B=000,W=000
	221-225	Pale Lavender	R=255,G=197,B=061,W=000
	226-230	Primary Green	R=077,G=255,B=000,W=000
	231-235	Bright Blue	R=000,G=255,B=087,W=000
	235-240	Apricot	R=255,G=143,B=013,W=000
	241-245	Pale Gold	R=253,G=171,B=026,W=000
	246-250	Deep Orange	R=222,G=084,B=000,W=000
	251-255	Flame Red	R=255,G=046,B=002,W=000
21CH	0-255	Preset CTO	Color temperature 2000K-8000K
	0-17	Off light	
	18-34	8000K	R=255,G=182,B=110,W=255
	35-51	7500K	R=255,G=144,B=089,W=255
	52-68	6500K	R=255,G=129,B=081,W=255
	69-85	6000K	R=255,G=121,B=073,W=255
	86-102	5600K	R=255,G=106,B=066,W=255
	03-119	5000K	R=255,G=090,B=055,W=255
	120-136	4500K	R=255,G=071,B=043,W=255
	137-153	4000K	R=255,G=055,B=034,W=255
	154-170	3500K	R=255,G=029,B=024,W=255
	171-187	3200K	R=255,G=011,B=019,W=255
	188-204	3000K	R=255,G=004,B=016,W=255
	205-221	2700K	R=255,G=000,B=009,W=203
	222-238	2500K	R=255,G=000,B=004,W=172
239-255	2000K	R=255,G=000,B=000,W=105	
22CH	0-255	LED1 Red	Dark to light
23CH	0-255	LED1 Green	Dark to light

24CH	0-255	LED1 Blue	Dark to light
25CH	0-255	LED1 White	Dark to light
....	....	....	....
....	....	....	....
46CH	0-255	LED7 Red	Dark to light
47CH	0-255	LED7 Green	Dark to light
48CH	0-255	LED7 Blue	Dark to light
49CH	0-255	LED7 White	Dark to light

**105CH Mode ( Support Dmx /Artnet/sACN. when u use DMX+Artnet mode, the 1-19CH are controlled by DMX protocol )**

Channel	Value	Function	Description
1CH	0-255	Pan Movement	0°- 540°
2CH	0-255	Fine Pan Movement positioning	16 bit adjustable
3CH	0-255	Tilt Movement	0°- 205°
4CH	0-255	Fine Tile Movement positioning	16 bit adjustable
5CH	0-255	P/T motors speed	fast to slow
6CH	0-255	Zoom	3.15°- 45° (From narrow to wide )
7CH	0-255	Fine Zoom positioning	
8CH	0-255	Lens Rotation	
	0-5	/	
	6-62	Lens Rotation 1	From left to right position (0-360°)
	63-127	Lens Rotation 2	From right to left position (0-360°)
	128-192	Lens Rotation 3	From left to right position (Infinite-Rotation) From slow to fast
	193-255	Lens Rotation 4	From right to left position (Infinite-Rotation) From slow to fast
9CH	0-255	Reset	
	0-200	/	
	201-215	Zoom/lens-rotation motors reset	The value stops for 5 seconds
	216-230	P/T motors reset	The value stops for 5 seconds
	231-245	Overall reset	The value stops for 5 seconds
	246-255	/	
10CH	0-255	Dimmer	
11CH	0-255	Shutter	
	0-5	/	
	6-55	Synchronous strobe	From slow to fast
	56-105	Pulse strobe	From slow to fast
	106-155	Random strobe	From slow to fast
	156-205	Fade Strobe1	From slow to fast Brightness from high to low
	206-255	Fade Strobe2	From slow to fast Brightness from low to high
12CH	0-255	60W LED - RED	Linear 0-100%
13CH	0-255	60W LED - GREEN	Linear 0-100%

14CH	0-255	60W LED - BLUE	Linear 0-100%
15CH	0-255	60W LED - WHITE	Linear 0-100%
16CH	0-255	Pixel Macro 60W	Program1-program16
	0-5	/	
	6-20	Program 1	The color-changes of the Pixel Macro 60W is controlled by its color CH
	21-35	Program 2	~
	36-50	Program 3	~
	51-65	Program 4	~
	66-80	Program 5	~
	81-95	Program 6	~
	96-110	Program 7	~
	111-125	Program 8	~
	126-140	Program 9	~
	141-155	Program 10	~
	156-170	Program 11	~
	171-185	Program 12	~
	186-200	Program 13	~
	201-215	Program 14	~
	216-230	Program 15	~
231-245	Program 16	~	
	246-255	Auto-running Pixel Macro 60W	Program 1-Program 16 Auto-running
17CH	0-255	Pixel Macro 60W Speed	From Slow to fast
18CH	0-255	Preset Colours	
	0-45		
	46-50	Cyan	R=000,G=255,B=255,W=000
	51-55	Yellow	R=255,G=255,B=000,W=000
	56-60	Magenta	R=255,G=000,B=255,W=000
	61-65	Medium Yellow	R=156,G=126,B=000,W=000
	66-70	Straw Tint	R=152,G=115,B=009,W=000
	71-75	Surprise Peach	R=198,G=114,B=009,W=000
	76-80	Fire	R=255,G=056,B=000,W=000
	81-85	Medium Amber	R=255,G=135,B=000,W=000
	86-90	Gold Amber	R=255,G=100,B=000,W=000
	91-95	Dark Amber	R=255,G=065,B=000,W=000
	96-100	Sunrise Red	R=255,G=083,B=002,W=000
	101-105	Light Pink	R=255,G=112,B=000,W=141
	106-110	Medium Pink	R=255,G=087,B=000,W=107
	111-115	Pink Carnation	R=255,G=107,B=000,W=130
	116-120	Light Lavender	R=243,G=117,B=039,W=197
	121-125	Sky Blue	R=000,G=255,B=135,W=000
126-130	Just Blue	R=000,G=194,B=130,W=000	
131-135	Dark yellow green	R=041,G=219,B=000,W=000	
136-140	Spring Yellow	R=245,G=202,B=000,W=000	

	141-145	Light Amber	R=237,G=163,B=000,W=000
	146-150	Straw Tint	R=230,G=160,B=000,W=069
	151-155	Deep Amber	R=255,G=166,B=000,W=000
	156-160	Orange	R=255,G=122,B=000,W=000
	161-165	Light Rose	R=255,G=141,B=031,W=000
	166-170	Middle Rose	R=217,G=130,B=028,W=000
	171-175	Dark Pink	R=255,G=109,B=033,W=000
	176-180	Magenta	R=255,G=020,B=015,W=000
	181-185	Peacock Blue	R=051,G=255,B=051,W=000
	186-190	Steel Blue	R=206,G=255,B=056,W=000
	191-195	Light Blue	R=074,G=255,B=082,W=000
	196-200	Dark Blue	R=000,G=186,B=255,W=000
	201-205	Leaf Green	R=206,G=255,B=000,W=000
	206-210	Dark Green	R=084,G=255,B=013,W=000
	211-215	Mauve	R=227,G=041,B=056,W=000
	216-220	Deep Golden Amber	R=255,G=058,B=000,W=000
	221-225	Pale Lavender	R=255,G=197,B=061,W=000
	226-230	Primary Green	R=077,G=255,B=000,W=000
	231-235	Bright Blue	R=000,G=255,B=087,W=000
	235-240	Apricot	R=255,G=143,B=013,W=000
	241-245	Pale Gold	R=253,G=171,B=026,W=000
	246-250	Deep Orange	R=222,G=084,B=000,W=000
	251-255	Flame Red	R=255,G=046,B=002,W=000
19CH	0-255	Preset CTO	
	0-17	Off light	
	18-34	8000K	R=255,G=121,B=073,W=255
	35-51	7500K	R=255,G=106,B=066,W=255
	52-68	6500K	R=255,G=090,B=055,W=255
	69-85	6000K	R=255,G=071,B=043,W=255
	86-102	5600K	R=255,G=055,B=034,W=255
	03-119	5000K	R=255,G=029,B=024,W=255
	120-136	4500K	R=255,G=011,B=019,W=255
	137-153	4000K	R=255,G=004,B=016,W=255
	154-170	3500K	R=255,G=000,B=009,W=203
	171-187	3200K	R=255,G=000,B=004,W=172
	188-204	3000K	R=255,G=000,B=000,W=105
	205-221	2700K	R=000,G=255,B=255,W=000
	222-238	2500K	R=255,G=255,B=000,W=000
239-255	2000K	R=255,G=000,B=255,W=000	
20CH	0-255	SMD Dimmer	Linear 0-100%
21CH	0-255	SMD Shutter	
	0-5	/	
	6-55	Synchronous strobe	From slow to fast
	56-105	Pulse strobe	From slow to fast
	106-155	Random strobe	From slow to fast



	156-205	Fade Strobe1	From slow to fast Brightness from high to low
	206-255	Fade Strobe1	From slow to fast Brightness from low to high
22CH	0-255	LED8 Red	Dark to light
23CH	0-255	LED8 Green	Dark to light
24CH	0-255	LED8 Blue	Dark to light
....	....	....	....
....	....	....	....
....	....	....	....
103CH	0-255	LED35 Red	Dark to light
104CH	0-255	LED35 Green	Dark to light
105CH	0-255	LED35 Blue	Dark to light

**127CH Mode ( Support Dmx /Artnet/sACN. when u use DMX+Artnet mode, the 1-9CH are controlled by DMX protocol )**

Channel	Value	Function	Description
1CH	0-255	Pan Movement	0°- 540°
2CH	0-255	Fine Pan Movement positioning	16 bit adjustable
3CH	0-255	Tilt Movement	0°- 205°
4CH	0-255	Fine Tile Movement positioning	16 bit adjustable
5CH	0-255	P/T motors speed	fast to slow
6CH	0-255	Zoom	3.15°- 45° (From narrow to wide )
7CH	0-255	Fine Zoom positioning	
8CH	0-255	Lens Rotation	
	0-5	/	
	6-62	Lens Rotation 1	From left to right position (0-360°)
	63-127	Lens Rotation 2	From right to left position (0-360°)
	128-192	Lens Rotation 3	From left to right position (Infinite-Rotation) From slow to fast
9CH	193-255	Lens Rotation 4	From right to left position (Infinite-Rotation) From slow to fast
	0-255	Reset	
	0-200	/	
	201-215	Zoom/lens-rotation motors reset	The value stops for 5 seconds
	216-230	P/T motors reset	The value stops for 5 seconds
	231-245	Overall reset	The value stops for 5 seconds
246-255	/		
10CH	0-255	Dimmer	From Dark to light
11CH	0-255	Shutter	
	0-5	/	
	6-55	Synchronous strobe	From slow to fast

	56-105	Pulse strobe	From slow to fast
	106-155	Random strobe	From slow to fast
	156-205	Fade Strobe1	From slow to fast Brightness from high to low
	206-255	Fade Strobe2	From slow to fast Brightness from low to high
12CH	0-255	Preset Colours	
	0-45		
	46-50	Cyan	R=000,G=255,B=255,W=000
	51-55	Yellow	R=255,G=255,B=000,W=000
	56-60	Magenta	R=255,G=000,B=255,W=000
	61-65	Medium Yellow	R=156,G=126,B=000,W=000
	66-70	Straw Tint	R=152,G=115,B=009,W=000
	71-75	Surprise Peach	R=198,G=114,B=009,W=000
	76-80	Fire	R=255,G=056,B=000,W=000
	81-85	Medium Amber	R=255,G=135,B=000,W=000
	86-90	Gold Amber	R=255,G=100,B=000,W=000
	91-95	Dark Amber	R=255,G=065,B=000,W=000
	96-100	Sunrise Red	R=255,G=083,B=002,W=000
	101-105	Light Pink	R=255,G=112,B=000,W=141
	106-110	Medium Pink	R=255,G=087,B=000,W=107
	111-115	Pink Carnation	R=255,G=107,B=000,W=130
	116-120	Light Lavender	R=243,G=117,B=039,W=197
	121-125	Sky Blue	R=000,G=255,B=135,W=000
	126-130	Just Blue	R=000,G=194,B=130,W=000
	131-135	Dark yellow green	R=041,G=219,B=000,W=000
	136-140	Spring Yellow	R=245,G=202,B=000,W=000
	141-145	Light Amber	R=237,G=163,B=000,W=000
	146-150	Straw Tint	R=230,G=160,B=000,W=069
	151-155	Deep Amber	R=255,G=166,B=000,W=000
	156-160	Orange	R=255,G=122,B=000,W=000
	161-165	Light Rose	R=255,G=141,B=031,W=000
	166-170	Middle Rose	R=217,G=130,B=028,W=000
	171-175	Dark Pink	R=255,G=109,B=033,W=000
	176-180	Magenta	R=255,G=020,B=015,W=000
	181-185	Peacock Blue	R=051,G=255,B=051,W=000
	186-190	Steel Blue	R=206,G=255,B=056,W=000
	191-195	Light Blue	R=074,G=255,B=082,W=000
	196-200	Dark Blue	R=000,G=186,B=255,W=000
	201-205	Leaf Green	R=206,G=255,B=000,W=000
206-210	Dark Green	R=084,G=255,B=013,W=000	
211-215	Mauve	R=227,G=041,B=056,W=000	
216-220	Deep Golden Amber	R=255,G=058,B=000,W=000	
221-225	Pale Lavender	R=255,G=197,B=061,W=000	
226-230	Primary Green	R=077,G=255,B=000,W=000	
231-235	Bright Blue	R=000,G=255,B=087,W=000	
235-240	Apricot	R=255,G=143,B=013,W=000	

	241-245	Pale Gold	R=253,G=171,B=026,W=000
	246-250	Deep Orange	R=222,G=084,B=000,W=000
	251-255	Flame Red	R=255,G=046,B=002,W=000
13CH	0-255	CTO Preset	Color temperature 2000K-8000K
	0-17	Off light	
	18-34	8000K	R=255,G=182,B=110,W=255
	35-51	7500K	R=255,G=144,B=089,W=255
	52-68	6500K	R=255,G=129,B=081,W=255
	69-85	6000K	R=255,G=121,B=073,W=255
	86-102	5600K	R=255,G=106,B=066,W=255
	03-119	5000K	R=255,G=090,B=055,W=255
	120-136	4500K	R=255,G=071,B=043,W=255
	137-153	4000K	R=255,G=055,B=034,W=255
	154-170	3500K	R=255,G=029,B=024,W=255
	171-187	3200K	R=255,G=011,B=019,W=255
	188-204	3000K	R=255,G=004,B=016,W=255
	205-221	2700K	R=255,G=000,B=009,W=203
	222-238	2500K	R=255,G=000,B=004,W=172
	239-255	2000K	R=255,G=000,B=000,W=105
14CH	0-255	LED 1 Red	Dark to light
15CH	0-255	LED 1 Green	Dark to light
16CH	0-255	LED 1 Blue	Dark to light
17CH	0-255	LED 1 White	Dark to light
....	....	....	....
....	....	....	....
....	....	....	....
....	....	....	....
....	....	....	....
38CH	0-255	LED 7 Red	Dark to light
39CH	0-255	LED 7 Green	Dark to light
40CH	0-255	LED 7 Blue	Dark to light
41CH	0-255	LED 7 White	Dark to light
42CH	0-255	SMD Dimmer	Master Dimmer of Aura LEDs
43CH	0-255	SMD Shutter	
	0-5	/	
	6-55	Synchronous strobe	From slow to fast
	56-105	Pulse strobe	From slow to fast
	106-155	Random strobe	From slow to fast
	156-205	Fade Strobe1	From slow to fast Brightness from high to low
	206-255	Fade Strobe1	From slow to fast Brightness from low to high
44CH	0-255	LED8 Red	Dark to light
45CH	0-255	LED8 Green	Dark to light
46CH	0-255	LED8 Blue	Dark to light
....	....	....	....
....	....	....	....

....	....	....	....
125CH	0-255	LED35 Red	Dark to light
126CH	0-255	LED35 Green	Dark to light
127CH	0-255	LED35 Blue	Dark to light

## SPECIFICATIONS

### SOURCE:

7pcs\* 60W RGBW LEDs  
 28pcs\* 0.5W RGB LEDs  
 50,000 Hour Average LED Life\*

### PHOTOMETRIC DATA:

7200 Total Lumen Output  
 CRI 80+  
 Zoom Range 3.15° - 45°

### EFFECT:

Motorized Zoom  
 Linear Color Temperature Presets (2000 -8000K)  
 RGBW Color -Mixing and Pixel-Control for each LEDs  
 Aura LEDs Effects ( RGB LEDs)  
 Color -Presets and Macros  
 Electronic Strobe and Variable Dimming Curves/16 - bit Dimming

### CONTROL / CONNECTIONS:

28/49/105/127 DMX Channel Modes  
 P/T Movement 540°/205°  
 Infinite-Lens-rotation  
 DMX Adjustable Refresh Rate (from 900 to 25000 Hz)  
 (4) Button Touch panel  
 Full Color 180°Reversible LCD Menu Display  
 DMX/ArtNet/sACN/RDM Support  
 Software upgrade via RJ45 cable

### SIZE / WEIGHT:

Length: 309.5 mm (12.19 in)  
 Width: 210 mm (8.27 in)  
 Height: 463 mm(18.23 in )  
 Weight: 12 KGS (26.46 lbs.)

### ELECTRICAL / THERMAL:

AC 100-240V 50/60Hz  
 700W Max Power Consumption  
 BTU/hr (+/- 10%) 2387

### APPROVALS/RATINGS:

CE | IP65

## Warranty

Please refer to your local dealer or please contact Event Lighting Pty Ltd.

# DIMENSIONAL DRAWINGS

