



SPIGOT FOLDING TRUSS

T55FF* Series

USER MANUAL



For safety, please read this user manual carefully before initial use.

Event Lighting reserves the right to revise the manual at any time. Information and specifications within this manual are subject to change without notice. Event Lighting assumes no liability or responsibility for any errors or omissions. Please consult Event Lighting for any clarification or information regarding this item.

www.eventec.com.au

Ver 1.0 (22.10.2024)

CONTENTS

Safety Instructions	2
Product Assembly	2
Product Dismantling	2
Load Ratings	3
Specifications	3
Warranty.....	3

Safety Instructions

WARNING

- Trusses and truss constructions can only be used to suspend static loads. Loading tables provided in this manual are only valid for static loads.
- The assembly has to be done by trained and competent persons. Working with a truss construction requires a certain professional knowledge. Please do not attempt to work with truss if you are unsure and lack knowledge; contact a rigging specialist for assistance.
- Treat the truss elements with care. Don't drop them, don't drag them around and don't throw sections on top of each other.
- Prevent damage from sharp edges such as the forks of a forklift.
- Unauthorized modifications on the trussing are forbidden due to safety reasons and void any form of load ratings.
- When rigging, dismantling, or servicing the trussing, make sure the area below installation place is blocked off.
- A competent person shall check prior to use if all trusses are connected properly before applying loads.

Product Assembly

The Event Lighting Ladder style truss requires the chords to be facing down for bracing when used in a horizontal position. Incorrect use will void any form of load ratings

- Check the truss, the truss pins, the couplers and the safety clips for any damages. If any piece is damaged replace it with new / undamaged products.
- Insert a coupler half-way into a main tube and check that the drillings in the coupler are aligned with the drillings in the main tube. The larger hole in the coupler must face outwards.
- Insert now a truss pin with the narrow side down and push it through. For a tolerance free connection, use a copper or synthetic hammer to drive the pin completely through the cone and main tube.
- Push a safety clip through the small hole of the truss pin. This secures the pin so that it cannot fall out.
- Repeat this step for each main tube. You might have to turn the truss to insert all truss pins and safety clips.
- Insert now the truss with the coupler side into the next truss you want to add and secure the main tubes of the second truss as well with all truss pins and safety clips.

Product Dismantling

- Remove all the safety clips.
- Push truss pins from the inside to the outside and remove them (If you use a synthetic or copper hammer to drive the pin out, be careful as the truss pin might fly off when you knock hard with the hammer).
- Loosen the connection and pull the truss apart.
- Collect and secure all couplers, truss pins and safety clips.

Load Ratings

SPAN (M)	3m	4m	5m	6m	7m	8m	9m	10m	11m	12m	13m	14m	15m	16m	17m	18m	19m	20m	21m	22m	23m	24m
Centre Point Load (kg)																						
	2153	1749	1395	1273	1085	1030	985	879	855	832	811	745	731	675	663	617	575	567	558	520	490	454
Deflection (mm)	2	4	10	14	21	31	46	56	63	77	94	105	123	137	156	172	197	217	233	261	285	307
Uniform Load (kg)																						
	2154	2147	2144	2112	1800	1711	1636	1461	1417	1381	1346	1235	1208	1120	1100	1021	955	940	924	866	811	758
Deflection (mm)	2	2	4	7	12	15	21	28	36	49	61	66	83	93	114	124	140	166	192	206	227	246

Specifications

530 x 580mm Aluminium Lighting Spigot Folding Truss,
3mm wall thickness

- Main Tube: 50mm x 3mm
- Diagonal Brace: 25mm x 2mm
- Materials: Aluminum alloy 6061-T6
- Finishing: Washed or Black
- Rating: TUV
- Dimensions (W H): 580 x 530 mm

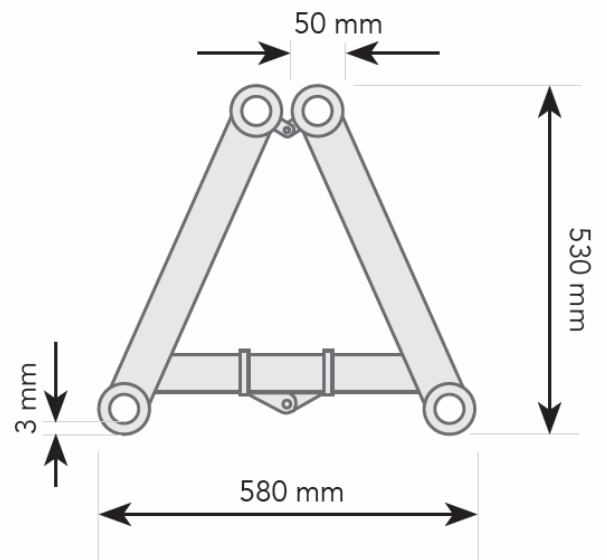

WARRANTY

Please refer to your local dealer or please contact Eventec

Website: www.eventec.com.au