



LED Pix Panel

PANX22

USER MANUAL



For safety, please read this user manual carefully before initial use.

Event Lighting reserves the right to revise the manual at any time. Information and specifications within this manual are subject to change without notice. Event Lighting assumes no liability or responsibility for any errors or omissions. Please consult Event Lighting for any clarification or information regarding this item.

www.event-lighting.com.au

Ver 1.0 (21.11.2024)

CONTENTS

Safety Instructions.....	2
Product Installation.....	2
Lux Chart	3
Dimensions	4
Control Board Operation	5-7
DMX Chart	8-11
Technical Specifications.....	12
Warranty	12

Safety Instructions

WARNING

- Do not open this device, there is no user-serviceable parts inside. Risk of electric shock.
- Do not look at the light source when the device is on.
- **CAUTION:** This unit's housing may be hot during and after operation.
- Install this device in a location with adequate ventilation, at least 20 inch (50 cm) from adjacent surfaces.
- Do not leave any flammable material within 50 cm of this unit while operating or connected to power.
- Use a safety chain when mounting this device overhead.
- Do not operate this device outdoors or in any location where dust, excessive heat, water, or humidity may affect it.
- Do not operate this device if the housing, lenses, or cables appear damaged.
- Do not connect this device to a dimmer or rheostat.
- ONLY connect this device to a grounded and protected circuit.
- ONLY use the hanging bracket to carry this device.
- In case of a serious operating problem, stop using immediately.
- The maximum ambient temperature is 104° F (40° C). Do not operate this device at higher temperatures.

Power Input & Power Linking

This device has an auto-switching power supply work with input voltage range of 100~240 VAC, 50/60 Hz. Link up to the maximum 15A. DO NOT exceed this.

Fuse Replacement

If the fine-wire fuse of the device fuses, only replace the fuse by a fuse of same type and rating. Before replacing the fuse, unplug mains lead.

Procedure:

- Step 1: Unscrew the fuse holder on the rear panel with a fitting screwdriver from the housing (anticlockwise).
- Step 2: Remove the old fuse from the fuse holder.
- Step 3: Install the new fuse in the fuse holder.
- Step 4: Replace the fuse holder in the housing and fix it.

Product Installation

This device can be mounted in many orientations provided each individual device is secured by the use of correct mounting bracket.

Use a safety chain when mounting this device overhead.

LUX CHART

Distance(m) 1.0 2.0 3.0 4.0 5.0

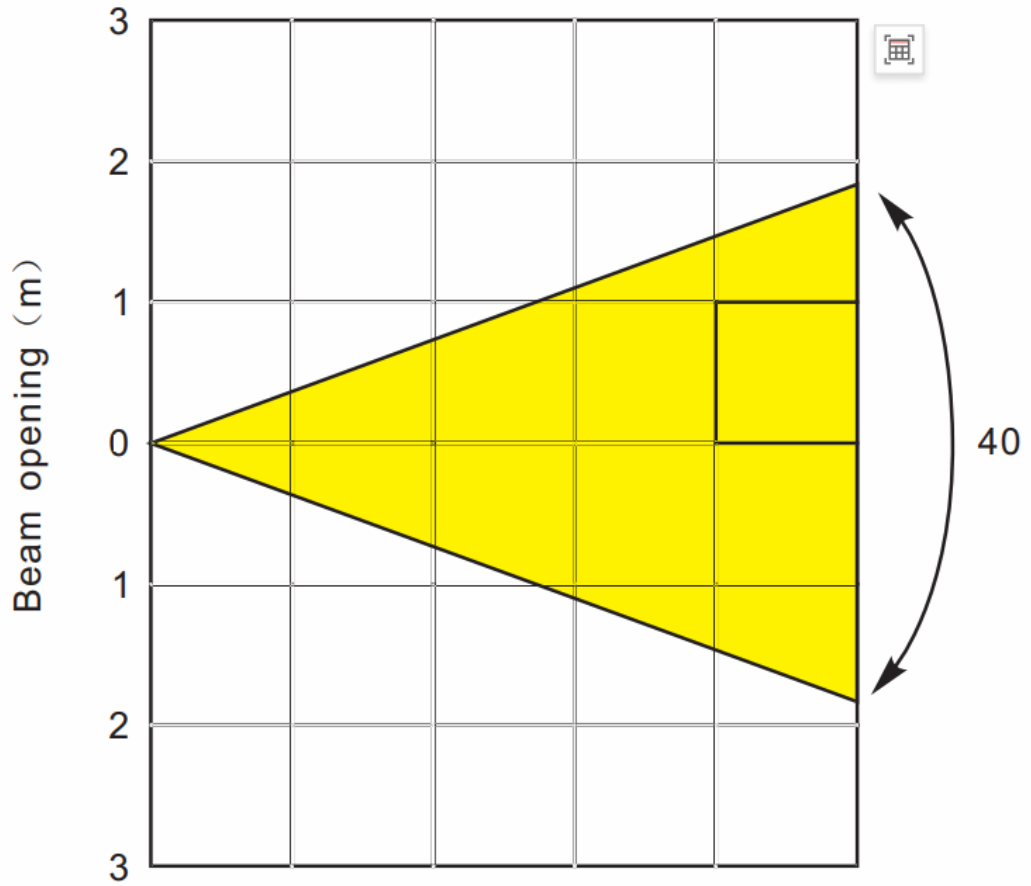

Diameter(m) Φ 0.73 Φ 1.46 Φ 2.18 Φ 2.91 Φ 3.64

40

Intensity LUX	R	770	200	100	60	45
G		1735	460	215	126	85
B		380	100	45	27	18
CW		2670	720	335	200	132
WW		2070	560	255	153	100
Full		7300	1965	905	540	355

DIMENSIONS

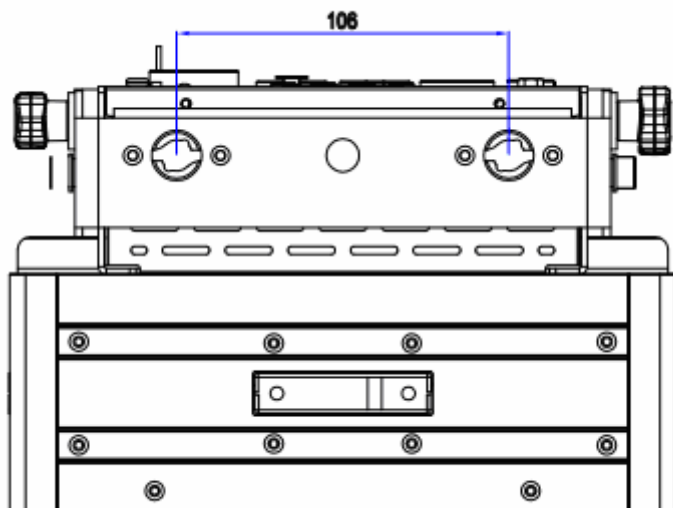
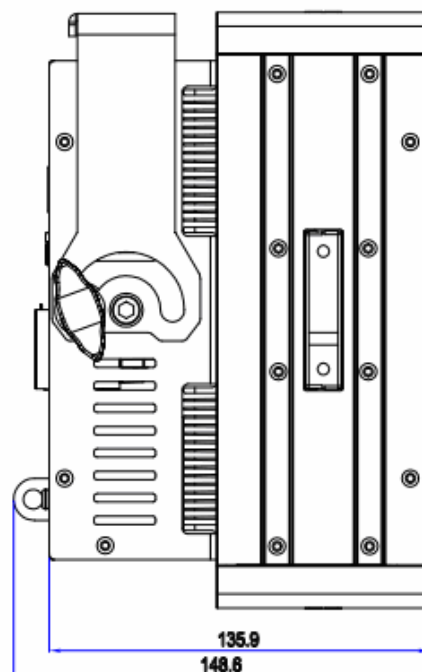
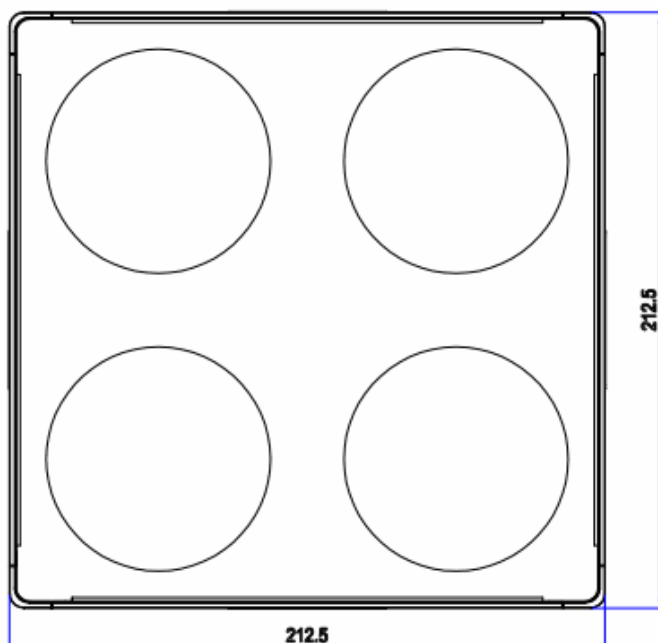

CONTROL BOARD OPERATION

Display	Options / Values	Function
1.DMX Address	<001> - <512>	Set DMX address
2.DMX Channel	<01> <02> <03> <4CW> <4WW> <08> <11> <12>	Select DMX channel mode
3.Dim Mode	<01> <02> <03> <04> <05>	Select dimmer curve
4.Static Color	R, G, B,C,W, RG, GB, RB, RGB...	Select static colour
5.Manual Color	R<000> - <255> G<000> - <255> B<000> - <255> CW<000> - <255> WW<000> - <255> Dim<000>- <255> Str<000> - <100>	Set intensity of each colour separately for color mixing and strobe rate
6.Manual White	WT<01>-<11> Dim<001>-<100>	Set intensity of 11 whites
7. Auto Program	<Pr01> - <Pr16> Sp<000> - <100> Dim<000> - <255>	Select built-in automatic programs, auto run speed and dimmer level
8.Sound Mode	<Sen:000> - <Sen:100>	Select sound active mode and the sensitivity level from Sen:<000> to Sen:<100>
9.Master/Slave	<M> <S>	Select Master/Slave modes
10.Temp	Temp< xxx °C>	Indicate the current temperature of the driver PCB (Celsius degree)
11.Update	<N>/ <Y>	Select to update firmware
	<START>	Use this fixture to update another fixture's software
12.Reset	<N>/<Y>	Recover manufactory default

DMX address

After select the "DMX Address" and press "Enter", then use "Up" and "Down" to set the desired DMX address, press "Enter" again to confirm.

DMX modes

After select the "DMX Channel" and press "Enter", then use "Up" and "Down" to set the desired DMX mode, press "Enter" again to confirm.

Dimmer curve

After select the "Dimmer Curve" and press "Enter", then use "Up" and "Down" to set the desired dimmer curve, press "Enter" again to confirm.

Set Static Colours

Mode:	Value:	Function:
Static Color	Static color <R>	Red
	Static color <G>	Green
	Static color 	Blue
	Static color <C>	Cool White
	Static color <W>	Warm White
	Static color <RG>	Red + Green
	Static color <BG>	Green + Blue
	Static color <RB>	Red + Blue
	Static color <RGB>	Red + Green + Blue

Entered "Static Color", you can select the desired solid color via the "Up" or "Down" buttons, then "Enter" to confirm.

Manual Colour mode

Entered "Manual Color" mode, use "Up" and "Down" button to select the each colour RGB intensity from 000 to 255, select strobe (S) speed from S000 to S100. (S000 is strobe off). Press "Enter" to save new setting.

Manual White mode

Entered "Manual White" mode, use "Up" and "Down" button to select each white intensity from 000 to 255, select strobe (S) speed from S000 to S100. (S000 is strobe off). Press "Enter" to save new setting.

Automatic Mode

Pr 01	Auto Run 1
Pr 02	Auto Run 2
Pr 03	Auto Run 3
Pr 04	Auto Run 4
Pr 05	Auto Run 5
Pr 06	Auto Run 6
Pr 07	Auto Run 7
Pr 08	Auto Run 8
Pr 09	Auto Run 9
Pr 10	Auto Run 10
Pr 11	Auto Run 11
Pr 12	Auto Run 12
Pr 13	Auto Run 13
Pr 14	Auto Run 14
Pr 15	Auto Run 15
Pr 16	Auto Run 16
Pr 17	Auto Run 17
Pr 18	Auto Run 18

Set auto run Pr01 - Pr18

Entered "Auto Program" mode, use "Up" and "Down" button to select the built-in programs. Press "Enter" and use "Up" and "Down" button to select auto run speed from <Sp000> to <Sp100>. Press "Enter" and use "Up" and "Down" button to select dimmer of "Auto Program" from <dim000> - <dim255>. Press "Enter" to save new setting.

Sound Mode

After select the "Sound mode", use "Up" and "Down" to set the sound sensitivity Sen 000 ~ Sen 100, press "Enter" to confirm.

Master/Slave Operation

1. Set the master fixture to one of the standalone operating modes: auto, sound, static color or manual color modes
2. Set the slaves, entered "Master/Slave" mode, set to "S", press "Enter"

Temperature

Select "Temp", the screen displays the current temperature of the fixture automatically.

Firmware update

Use fixture A to update fixture B's firmware

- Set fixture A to "Update" mode, select "Y" then select "START"
- Link fixture A and fixture B with DMX cable, then power up fixture B
- Press "Enter" on fixture A, fixture B's firmware will be copied from fixture A.

*Ensure that fixture A and B are of the same type, otherwise damage may occur.

* Only fixture A and B should be in the DMX chain when updating firmware.

Reset

To recover factory default, select the "Factory Set" and press "Enter", then use "Up" and "Down" to choose "Yes", press "Enter" again to confirm to recover manufactory default

DMX CHART

1 channels mode

Channel	Value	Function
1	000-255	dimmer 0% ~ 100% (dim the preset color selected in Menu)

2 channels mode

Channel	Value	Function
1	000-255	Warm white to cool white
2	000-255	Dimmer 0% ~ 100%

3 channels mode

Channel	Value	Function
1	000-255	Red: 0% ~ 100%
2	000-255	Green: 0% ~ 100%
3	000-255	Blue: 0% ~ 100%

4CW channels mode

Channel	Value	Function
1	000-255	Red: 0% ~ 100%
2	000-255	Green: 0% ~ 100%
3	000-255	Blue: 0% ~ 100%
4	000-255	Cool White: 0% ~ 100%

4WW channels mode

Channel	Value	Function
1	000-255	Red: 0% ~ 100%
2	000-255	Green: 0% ~ 100%
3	000-255	Blue: 0% ~ 100%
4	000-255	Warm White: 0% ~ 100%

8 channels mode

Channel	Value	Function
1	000-255	Red: 0% ~ 100%
2	000-255	Green: 0% ~ 100%
3	000-255	Blue: 0% ~ 100%

4	000-255	Cool White: 0% ~ 100%
5	000-255	Warm White: 0% ~ 100%
6	000-255	Dimmer Coarse
7	000-255	Dimmer Fine
8	000-015	No function (Shutter On)
	016-119	Strobe Slow -> Fast(1-25HZ)
	120-127	No function (Shutter On)
	128-183	Strobe Random Slow -> Fast
	184-191	No function (Shutter On)
	192-247	Strobe Audio sensitivity low -> high
	248-255	No function (Shutter On)

11 channels mode

Channel	Value	Function	
1	000-255	Red: 0% ~ 100%	
2	000-255	Green: 0% ~ 100%	
3	000-255	Blue: 0% ~ 100%	
4	000-255	Cool White: 0% ~ 100%	
5	000-255	Warm White: 0% ~ 100%	
6	000-255	Master Dimmer 0% ~ 100%	
7	000-015	No function (Shutter On)	
	016-119	Strobe Slow -> Fast(1-25HZ)	
	120-127	No function (Shutter On)	
	128-183	Strobe Random Slow -> Fast	
	184-191	No function (Shutter On)	
	192-247	Strobe Audio sensitivity low -> high	
	248-255	No function (Shutter On)	
8	000-019	No Function	
	020-039	RED 100% / GREEN 0% ~ 100% / BLUE 0%	
	040-059	RED 100% ~ 0% / GREEN 100% / BLUE 0%	
	060-079	RED 0% / GREEN 100% / BLUE 0% ~ 100%	
	080-099	RED 0% / GREEN 100% ~ 0% / BLUE 100%	
	100-119	RED 0% ~ 100% / GREEN 0% / BLUE 100%	
	120-139	RED 100% / GREEN 0% / BLUE 100% ~ 0%	
	140-159	RED 100% / GREEN 0% ~ 100% / BLUE 0% ~ 100%	
	160-179	RED 100%~ 0% / GREEN 100% ~ 0% / BLUE 100%	
	180-200	RED 100% / GREEN 100% / BLUE 100%	
	201-204	Color Temperature 1	Warm ↓
	205-209	Color Temperature 2	
	210-214	Color Temperature 3	
	215-219	Color Temperature 4	

	220-224	Color Temperature 5	 Cool
	225-229	Color Temperature 6	
	230-234	Color Temperature 7	
	235-239	Color Temperature 8	
	240-244	Color Temperature 9	
	245-249	Color Temperature 10	
	250-255	Color Temperature 11	
9	000-009	No Function	
	010-021	Auto Run 1	
	022-034	Auto Run 2	
	035-047	Auto Run 3	
	048-060	Auto Run 4	
	061-073	Auto Run 5	
	074-086	Auto Run 6	
	087-099	Auto Run 7	
	100-112	Auto Run 8	
	113-125	Auto Run 9	
	126-138	Auto Run 10	
	139-151	Auto Run 11	
	152-164	Auto Run 12	
	165-177	Auto Run 13	
	178-190	Auto Run 14	
	191-203	Auto Run 15	
	204-216	Auto Run 16	
	217-229	Auto Run 17	
230-242	Auto Run 18		
243-255	Sound active mode		
10	000-255	Speed of ch9 auto programs (slow ~ fast) or sound sensitivity	
11	000-009	Use dimmer curve from setting of control board	
	010-057	Dimmer Curve 1	
	058-106	Dimmer Curve 2	
	107-155	Dimmer Curve 3	
	156-204	Dimmer Curve 4	
	205-255	Dimmer Curve 5	

22 channels mode

Channel	Value	Function
1	000-255	LED 1 Red: 0% ~ 100%
2	000-255	LED 1 Green: 0% ~ 100%
3	000-255	LED 1 Blue: 0% ~ 100%
4	000-255	LED 1 Cool White: 0% ~ 100%
5	000-255	LED 1 Warm White: 0% ~ 100%
6	000-255	LED 2 Red: 0% ~ 100%
7	000-255	LED 2 Green: 0% ~ 100%
8	000-255	LED 2 Blue: 0% ~ 100%
9	000-255	LED 2 Cool White: 0% ~ 100%
10	000-255	LED 2 Warm White: 0% ~ 100%
11	000-255	LED 3 Red: 0% ~ 100%
12	000-255	LED 3 Green: 0% ~ 100%
13	000-255	LED 3 Blue: 0% ~ 100%
14	000-255	LED 3 Cool White: 0% ~ 100%
15	000-255	LED 3 Warm White: 0% ~ 100%
16	000-255	LED 4 Red: 0% ~ 100%
17	000-255	LED 4 Green: 0% ~ 100%
18	000-255	LED 4 Blue: 0% ~ 100%
19	000-255	LED 4 Cool White: 0% ~ 100%
20	000-255	LED 4 Warm White: 0% ~ 100%
21	000-255	Master Dimmer 0% ~ 100%
22	000-015	No function (Shutter On)
	016-119	Strobe Slow -> Fast(1-25HZ)
	120-127	No function (Shutter On)
	128-183	Strobe Random Slow -> Fast
	184-191	No function (Shutter On)
	192-247	Strobe Audio sensitivity low -> high
	248-255	No function (Shutter On)

TECHNICAL SPECIFICATIONS

Power

- Input Voltages: 100V~240V AC,50/60Hz
- Power Consumption: 120W
- Power Connection:Seetronic Power Input and Output Connection
- Fuse: T 2 A, 250 V

Photometrics

- Light Source: 4 pcs 40W RGB / CW / WW COB LEDs
- Beam Angle: 40°
- Field Angle: 60°
- Output: 1965 lux @2.0 M RGBWS full on
- PWM: 1200 Hz
- LED Life: 50,000 hours

Effects

- Dimming: 5 16bit digital Dimming Curves
- Strobe: 1 - 25 Hz

Control

- Operational Modes: Static, Color Fade, Auto Program, Sound Active, Multi Fixture Chases, Master / Slave & DMX Modes,RDM, WDMX(Optional)
- Display: 4-button LCD Display Control Panel
- DMX Protocol: DMX512
- DMX Channel Mode: 1 / 2 / 3 / 4CW / 4WW / 8 / 11 /22
- DMX Interface: 5-Pin (Optional 3-Pin XLR)
- Software Upgrade via DMX: Yes

Housing

- Housing Materials: Aluminium Housing
- Housing finish: Matte Black
- Cooling: Fanless Cooling
- Dimension: 213 x 213 x 136mm
- Net Weight: 3.85 kg

WARRANTY

Please refer to your local dealer or please contact Event Lighting Pty Ltd

Website: www.event-lighting.com.au