



LED Pro Par with RGBWA+UV LEDs PAR5H, PAR12H

USER MANUAL



For safety, please read this user manual carefully before initial use.

Event Lighting reserves the right to revise the manual at any time. Information and specifications within this manual are subject to change without notice. Event Lighting assumes no liability or responsibility for any errors or omissions. Please consult Event Lighting for any clarification or information regarding this item.

CONTENTS

Safety Instructions	2
Product Installation	2
Diagrams	3
Control Board Operation	5
DMX chart.....	9
Technical specifications.....	13
Warranty.....	14

Safety Instructions

WARNING

- Do not open this device, there is no user-serviceable parts inside. Risk of electric shock.
- Do not look at the light source when the device is on.
- **CAUTION:** This unit's housing may be hot during and after operation.
- Install this device in a location with adequate ventilation, at least 20 inch (50 cm) from adjacent surfaces.
- Do not leave any flammable material within 50 cm of this unit while operating or connected to power.
- Use a safety chain when mounting this device overhead.
- Do not operate this device outdoors or in any location where dust, excessive heat, water, or humidity may affect it.
- Do not operate this device if the housing, lenses, or cables appear damaged.
- Do not connect this device to a dimmer or rheostat.
- **ONLY** connect this device to a grounded and protected circuit.
- **ONLY** use the hanging bracket to carry this device.
- In case of a serious operating problem, stop using immediately.
- The maximum ambient temperature is 104° F (40° C). Do not operate this device at higher temperatures.

Power Input & Power Linking

This device has an auto-switching power supply work with input voltage range of 100~240 VAC, 50/60 Hz.

Link up to the maximum 15A. DO NOT exceed this number.

Product Installation

This device can be mounted in many orientations provided each individual device is secured by the use of correct mounting bracket.

Use a safety chain when mounting this device overhead.

Fuse Replacement

If the fine-wire fuse of the device fuses, only replace the fuse by a fuse of same type and rating.

Before replacing the fuse, unplug mains lead.

Procedure:

Step 1: Unscrew the fuse holder on the rear panel with a fitting screwdriver from the housing (anticlockwise).

Step 2: Remove the old fuse from the fuse holder.

Step 3: Install the new fuse in the fuse holder.

Step 4: Replace the fuse holder in the housing and fix it.

Lux Chart

PAR5H

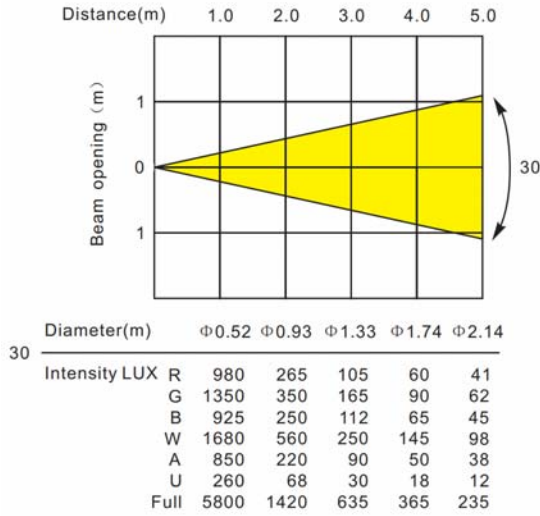

PAR12H

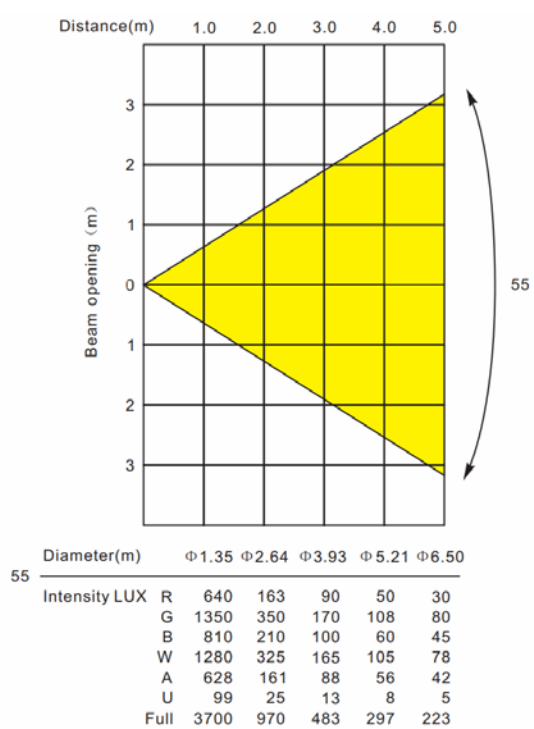
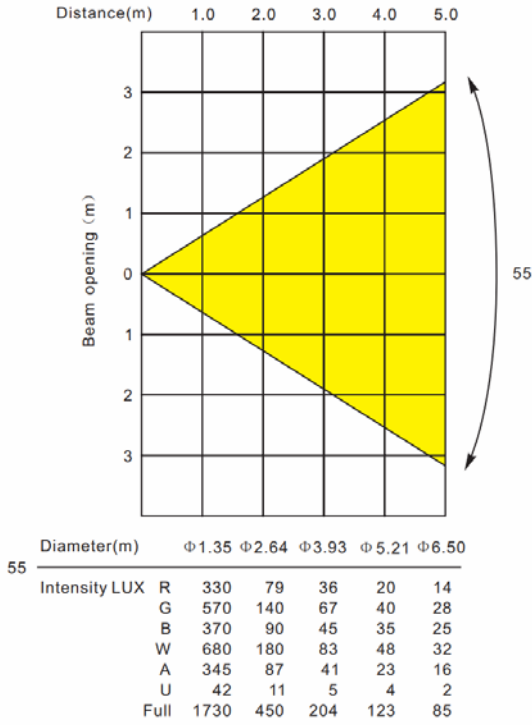
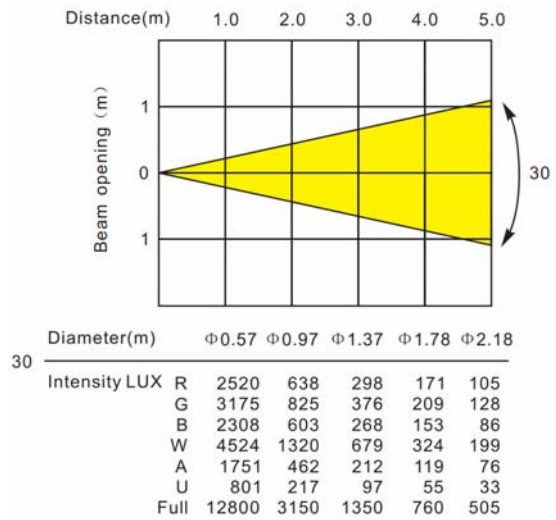

Dimensions

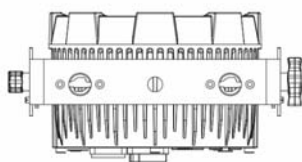

PAR5H

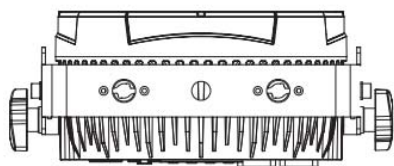
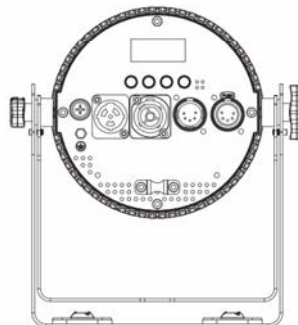
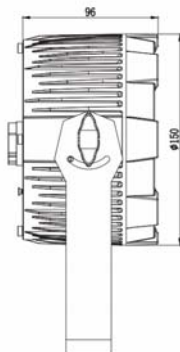
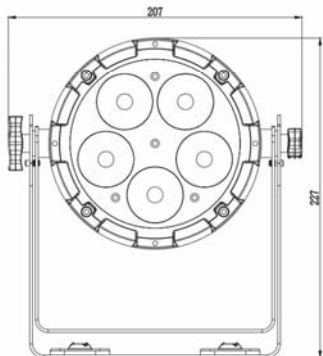

PAR12H

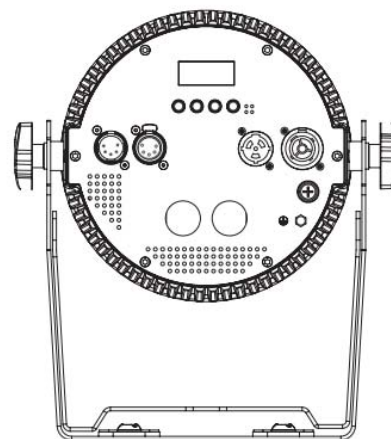
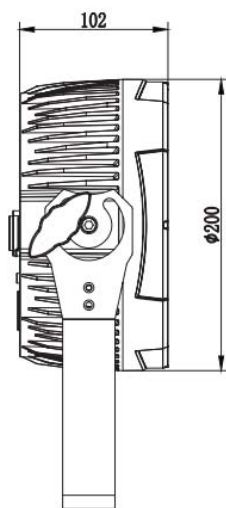
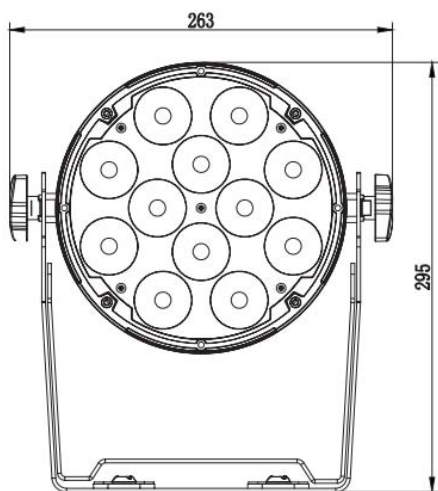

CONTROL BOARD OPERATION

Display	Options / Values	Function
DMX Add	<001> - <512>	Set DMX address
DMX Cha	<02> <03> <06> <08> <12>	Select DMX channel mode
Dimmer	<01> <02> <03> <04> <05>	Select dimmer curve
Sound	<Sen000> - <Sen100>	Select sound active mode and the sensitivity level from <Sen000> - <Sen100>
StaticC	R,G,B,W,A,U,GB,RB,RG,RGB,RW,GW,BW,WA,RA,GA,BA,RGW,RBW,GBW,RGBW,GBA,BWA,RGA,GWA,RWA,RGBA,GBWA,RBWA,RGWA,RGBQA,RU,GU,AU,RAU,RGBWAU	Select static colour
ManualC	R<000> - <255> G<000> - <255> B<000> - <255> W<000> - <255> A<000> - <255> UV<000> - <255> S<000> - S<100>	Set intensity of each colour separately for color mixing and strobe rate
Manual W	WT<001> - <011> <Dim000> - <Dim255>	Set the colour temperature WCT 01-11 and adjust the brightness
Auto Pr	<Pr01> - <Pr07> <Sp000> - <Sp100> <Dim000> - <Dim255>	Select built-in automatic programs, auto run speed and dimmer level
Wireless	<ON><OFF> <EL Mode> <W-DMX_R> <W-DMX_T>	You need to install WDMX module inside the fixture first and then receive the DMX signal from the transmitter attached to the console by setting this on
Mas/Slav	<M> <S>	Select Master/Slave modes
Reset	<N> <Y>	Recover manufactory default

DMX Address

After select the "DMX Add" and press "Enter", use "Up" and "Down" button to select the desired DMX address, press "Enter" to save new setting

DMX Mode

After select the "DMX Cha" and press "Enter", use "Up" and "Down" button to select the desired DMX mode, press "Enter" to save new setting

Dimmer Curve

After select the "Dimmer" and press "Enter", use "Up" and "Down" button to select the desired dimmer curves

Sound Active Mode

Entered "sound" mode, use "Up" and "Down" button to select the sensitivity Sen000-Sen100, press "Enter" to save new setting

Static Colour Mode

Entered "Static C" mode, you can select the desired solid color via the "UP" or "DOWN" buttons, press "Enter" to save new setting

Value:	Function:
R	Red
G	Green
B	Blue
W	White
A	Amber
UV	UV
GB	Green + Blue
RG	Red + Green
RB	Red + Blue
RW	Red + White
GW	Green + White
BW	Blue + White
WA	White + Amber
RA	Red + Amber
GA	Green + Amber
BA	Blue + Amber
RGB	Red + Green + Blue
RGW	Red + Green + White
RBW	Red + Blue + White
GBW	Green + Blue + White
GBA	Green + Blue + Amber
BWA	Blue + White + Amber
RGA	Red + Green + Amber
GWA	Green + White + Amber
RWA	Red + White + Amber
RGBA	Red + Green + Blue + Amber
GBWA	Green + Blue + White + Amber

RGBW	Red + Green + Blue + White
RBWA	Red + Blue + White + Amber
RGWA	Red + Green + White + Amber
EGBWA	Red + Green + Blue + White + Amber
RU	Red + UV
GU	Green + UV
AU	Amber + UV
RAU	Red + Amber + UV
...
RGBWAU	Red + Green + Blue + White + Amber + UV

Manual Color Mode

Entered "Manual C" mode, use "Up" and "Down" button to select the each colour (RGBW or RGBA) intensity from 000 to 255, select strobe (S) speed from S000 to S100. (S000 is strobe off). Press "Enter" to save new setting.

Manual WCT

Select the colour temperature from <WT01> - <WT11>, then use <Up> or <Down> to select intensity between 1 – 100, Press <Enter> to confirm.

Auto Run Mode

	Function
Pr 01	R G B W A UV colour switching
Pr 02	36 colour switching
Pr 03	R G B W A UV colour fading
Pr 04	36 colour fading
Pr 05	Color Macros Fading
Pr 06	Sound active mode
Pr 07	Multi fixture chases

Set auto run Pr 01 - Pr 05

Entered "Auto Pro" mode, use "Up" and "Down" button to select the built-in programs. Press "Enter" and use "Up" and "Down" button to select auto run speed from <Sp000> to <Sp100>. Press "Enter" and use "Up" and "Down" button to select dimmer of "Auto Pro" from <dim000> – <dim255>. Press "Enter" to save new setting.

Set sound active mode Pr 06

Entered "Auto Pro" mode, use "Up" and "Down" button to select the built-in program "Pr 06", press "Enter" and use "Up" and "Down" button to select the sound sensitivity level from <Sen000> to <Sen100>, press "Enter" to save new setting.

Set multi fixture chases Pr 07

Before starting, go to each fixture and reset the menu to fixture defaults.

1. On the master unit, setup the DMX address to the total number of fixtures in the string. For example, you may have a total of 20 par cans including the master, so the DMX address should be set to "20".
2. On the master unit, go to master/slave menu setting and set the unit to master
3. On the master unit, set the unit to "Auto Mode" "Pr 07" which supports multi fixture chases.

4. On each slave unit, setup the DMX address to the fixture position in the string. For example, if this unit is the 2nd unit in the string including the master, then set the DMX address to 2. If this the last unit of 20, then the DMX address should be set to 20. It is possible to double up fixture positions as well as fixture 1.
5. On each slave, go to the master/slave menu setting and set it to slave.

Master/Slave Operation

Set the master fixture to one of the stand-alone operating modes: automatic, sound, static color or manual color modes.

Set the slaves, entered "Mas/Sla" mode, set to "S", press "Enter" to confirm.

DMX Chart**1 channels Mode**

Channel	Value	Function
1	000-255	dimmer 0% ~ 100% (dim the preset color selected in Menu)

2 channels Mode

Channel	Value	Function
1	000-255	Warm white to cool white
2	000-255	dimmer 0% ~ 100%

3 channels Mode

Channel	Value	Function
1	000-255	Red: 0% ~ 100%
2	000-255	Green: 0% ~ 100%
3	000-255	Blue: 0% ~ 100%

4W channels Mode

Channel	Value	Function
1	000-255	Red: 0% ~ 100%
2	000-255	Green: 0% ~ 100%
3	000-255	Blue: 0% ~ 100%
4	000-255	White: 0% ~ 100%

4A channels Mode

Channel	Value	Function
1	000-255	Red: 0% ~ 100%
2	000-255	Green: 0% ~ 100%
3	000-255	Blue: 0% ~ 100%
4	000-255	Amber: 0% ~ 100%

6 channels Mode

Channel	Value	Function
1	000-255	Red: 0% ~ 100%
2	000-255	Green: 0% ~ 100%
3	000-255	Blue: 0% ~ 100%
4	000-255	White: 0% ~ 100%
5	000-255	Amber: 0% ~ 100%
6	000-255	UV: 0% ~ 100%

8 channels Mode

Channel	Value	Function
1	000-255	Red: 0% ~ 100%
2	000-255	Green: 0% ~ 100%
3	000-255	Blue: 0% ~ 100%
4	000-255	White: 0% ~ 100%
5	000-255	Amber: 0% ~ 100%
6	000-255	UV: 0% ~ 100%
7	000-255	Master Dimmer 0% ~ 100%
8	000-009	No function
	010-019	Sound Active
	020-255	Strobe : Slow ~ Fast (1~30Hz)

12 channels Mode

RGBW Channel	Value	Function	
1	000-255	Red: 0% ~ 100%	
2	000-255	Green: 0% ~ 100%	
3	000-255	Blue: 0% ~ 100%	
4	000-255	RGBW Model : White: 0% ~ 100%	
5	000-255	Amber: 0% ~ 100%	
6	000-255	UV: 0% ~ 100%	
7	000-255	Master Dimmer 0% ~ 100% for CH1, 2, 3, 4, 5, 6 & 8	
8	000-009	Strobe OFF	
	010-255	Strobe (slow-fast 1-30Hz)	
9	000-019	No Function	
	020-039	RED 100% / GREEN 0% ~ 100% / BLUE 0%	
	040-059	RED 100% ~ 0% / GREEN 100% / BLUE 0%	
	060-079	RED 0% / GREEN 100% / BLUE 0% ~ 100%	
	080-099	RED 0% / GREEN 100% ~ 0% / BLUE 100%	
	100-119	RED 0% ~ 100% / GREEN 0% / BLUE 100%	
	120-139	RED 100% / GREEN 0% / BLUE 100% ~ 0%	
	140-159	RED 100% / GREEN 0% ~ 100% / BLUE 0% ~ 100%	
	160-179	RED 100%~ 0% / GREEN 100% ~ 0% / BLUE 100%	
	180-200	RED 100% / GREEN 100% / BLUE 100%	
	201-204	Color Temperature 1	
	205-209	Color Temperature 2	
	210-214	Color Temperature 3	
	215-219	Color Temperature 4	
	220-224	Color Temperature 5	
	225-229	Color Temperature 6	
230-234	Color Temperature 7		
235-239	Color Temperature 8		
240-244	Color Temperature 9		
245-249	Color Temperature 10		
250-255	Color Temperature 11		
10	000-009	No Function	
	010-049	R G B W A UV colour switching	
	050-090	36 colour switching	
	091-131	RGBW Model : R G B W A UV colour fading	
	132-172	36 colour fading	
	173-213	Color Macros Fading	
	214-255	Sound active mode	
11	000-255	Speed of auto programs (slow ~ fast) or sound sensitivity for CH10 sound active mode	
	000-009	Use dimmer curve from setting of control board	
	010-057	16 bits Linear dimmer 1	

12	058-106	16 bits Non-linear dimmer 2
	107-155	16 bits Non-linear dimmer 3
	156-204	16 bits Non-linear dimmer 4
	205-255	8 bits Linear dimmer 5

14 channels Mode

Channel	Value	Function
1	000-255	Red Dim Coarse
2	000-255	Red Dim Fine
3	000-255	Green Dim Coarse
4	000-255	Green Dim Fine
5	000-255	Blue Dim Coarse
6	000-255	Blue Dim Fine
7	000-255	White Dim Coarse
8	000-255	White Dim Fine
9	000-255	Amber Dim Coarse
10	000-255	Amber Dim Fine
11	000-255	UV Dim Coarse
12	000-255	UV Dim Fine
13	000-255	Max Intensity
14	000-009	No Function
	010-019	Sound Active
	020-255	Strobe Slow-fast

TECHNICAL SPECIFICATIONS

Model	PAR5H	PAR12H
Dimensions and Weight		
Overall size LxWxH (mm)	207x227x120	263x293x98
Weight (kg)	1.9	3.2
Power		
Power Supply	100~240V AC, 50/60 Hz	
Power Consumption (w)	50	120
Fuse	T 1 A, 250 V	T 2 A, 250 V
LED	5pcs 12W RGBWA+UV 6 in 1 LED	12pcs 12W RGBWA+UV 6 in 1 LED
Operation Modes	DMX, WDMX, auto run, sound active, master/slave, manual colour control, static colour control	
Beam Angle	30°/ optional 55°	
Refresh Rate	2940Hz	
DMX Channel mode	1,2, 3, 4W,4A,6, 8,12,14	
DMX interface	5-pin XLR in / out	
Power Input	Seetronic True 1	
Power Output	Seetronic True 1	

WARRANTY

Please refer to your local dealer or please contact Eventec

Website: www.eventec.com.au