



PRO PAR

Model No. PARRGBW12x8, PAR12x8A

PARRGBW5x8, PAR5x8A

USER MANUAL



For safety, please read this user manual carefully before initial use.

Event Lighting reserves the right to revise the manual at any time. Information and specifications within this manual are subject to change without notice. Event Lighting assumes no liability or responsibility for any errors or omissions. Please consult Event Lighting for any clarification or information regarding this item.

www.event-lighting.com.au

Ver 2.3

CONTENTS

Safety Instructions

Product Installation

Diagrams

Control Board Operation

DMX chart

Technical specifications

Warranty

Safety Instructions

WARNING

- Do not open this device, there is no user-serviceable parts inside. Risk of electric shock.
- Do not look at the light source when the device is on.
- **CAUTION:** This unit's housing may be hot during and after operation.
- Install this device in a location with adequate ventilation, at least 20 inch (50 cm) from adjacent surfaces.
- Do not leave any flammable material within 50 cm of this unit while operating or connected to power.
- Use a safety chain when mounting this device overhead.
- Do not operate this device outdoors or in any location where dust, excessive heat, water, or humidity may affect it.
- Do not operate this device if the housing, lenses, or cables appear damaged.
- Do not connect this device to a dimmer or rheostat.
- **ONLY** connect this device to a grounded and protected circuit.
- **ONLY** use the hanging bracket to carry this device.
- In case of a serious operating problem, stop using immediately.
- The maximum ambient temperature is 104° F (40° C). Do not operate this device at higher temperatures.

Power Input & Power Linking

This device has an auto-switching power supply work with input voltage range of 100~240 VAC, 50/60 Hz.

Link up to the maximum 15A. DO NOT exceed this number.

Product Installation

This device can be mounted in many orientations provided each individual device is secured by the use of correct mounting bracket.

Use a safety chain when mounting this device overhead.

Fuse Replacement

If the fine-wire fuse of the device fuses, only replace the fuse by a fuse of same type and rating.

Before replacing the fuse, unplug mains lead.

Procedure:

Step 1: Unscrew the fuse holder on the rear panel with a fitting screwdriver from the housing (anticlockwise).

Step 2: Remove the old fuse from the fuse holder.

Step 3: Install the new fuse in the fuse holder.

Step 4: Replace the fuse holder in the housing and fix it.

Lux Chart

PARRGBW5X8

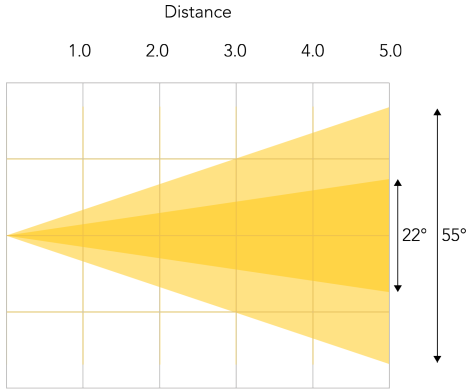

LUX @ 22°	∅ 0.39	∅ 0.78	∅ 1.17	∅ 1.56	∅ 1.94
R	1,784	457	210	118	78
G	1,743	467	213	121	81
B	2,327	588	273	149	98
W	2,648	786	357	201	135
Full	7,190	1,910	883	489	338

LUX @ 55°	∅ 1.04	∅ 2.08	∅ 3.12	∅ 4.16	∅ 5.21
R	636	147	69	39	28
G	1,020	263	121	72	48
B	640	160	70	40	30
W	1,080	274	127	74	51
Full	2,570	668	307	178	123

PAR5X8A

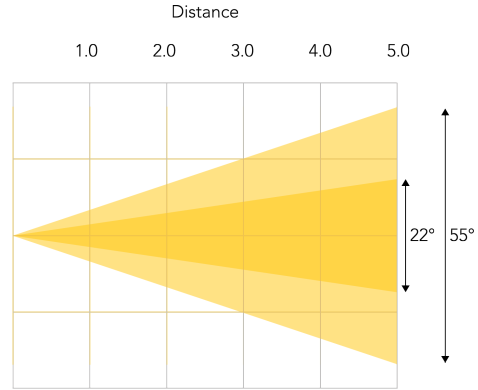

LUX @ 22°	∅ 0.39	∅ 0.78	∅ 1.17	∅ 1.56	∅ 1.94
R	2,600	626	271	157	108
G	2,810	728	325	190	120
B	2,100	500	230	135	82
A	2,310	520	260	142	95
Full	5,350	1,350	605	348	235

LUX @ 55°	∅ 1.04	∅ 2.08	∅ 3.12	∅ 4.16	∅ 5.21
R	620	153	76	44	32
G	757	203	96	58	43
B	550	130	70	40	30
A	630	163	82	48	35
Full	1,700	460	225	137	100

PARRGBW12X8

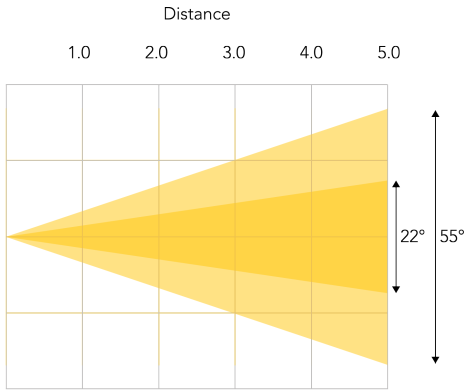

LUX @ 22°	∅ 0.39	∅ 0.78	∅ 1.17	∅ 1.56	∅ 1.94
R	3,957	977	430	245	160
G	3,900	1,092	485	280	185
B	4,690	1,200	558	308	205
W	6,000	1,700	747	428	282
Full	15,740	4,310	1,911	1,056	693

LUX @ 55°	∅ 1.04	∅ 2.08	∅ 3.12	∅ 4.16	∅ 5.21
R	1,405	325	155	90	68
G	2,480	655	310	190	130
B	2,450	580	270	165	96
W	3,190	840	395	240	165
Full	6,850	1,785	845	520	360

PAR12X8A

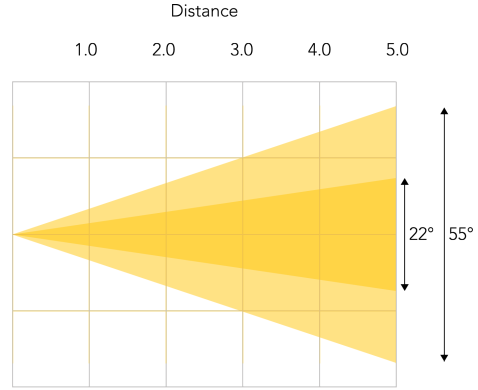

LUX @ 22°	∅ 0.39	∅ 0.78	∅ 1.17	∅ 1.56	∅ 1.94
R	5,300	1,510	665	383	244
G	6,800	1,930	871	512	342
B	4,100	110	490	285	195
A	4,860	1,450	591	365	225
Full	15,110	4,200	1,920	1,142	757

LUX @ 55°	∅ 1.04	∅ 2.08	∅ 3.12	∅ 4.16	∅ 5.21
R	1,400	345	153	86	62
G	1,658	440	207	124	87
B	1,150	280	130	80	50
A	1,350	357	167	93	65
Full	3,940	1,030	470	280	192

Dimensions

PAR5

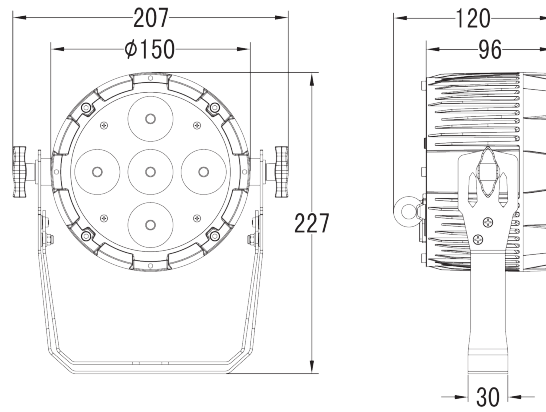

PAR12

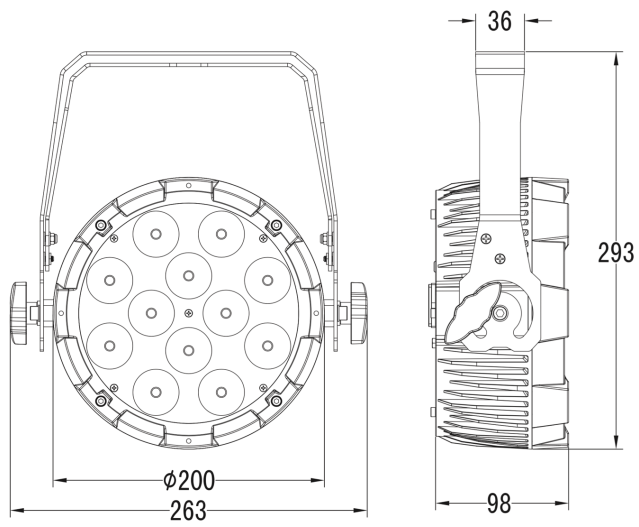

CONTROL BOARD OPERATION

Display	Options / Values	Function
DMX Add	<001> - <512>	Set DMX address
DMX Cha	<02> <03> <04> <06> <10>	Select DMX channel mode
Dimmer	<01> <02> <03> <04> <05>	Select dimmer curve
Sound	<Sen000> - <Sen100>	Select sound active mode and the sensitivity level from <Sen000> - <Sen100>
StaticC	RGBW Models: R, G, B, W, GB, RB, RG, RGB, RW, GW, BW, RGW, RBW, GBW, RGBW RGBA Models: R, G, B, A, GB, RB, RG, RGB, RA, GA, BA, RGA, RBA, GBA, RGBA	Select static colour
ManualC	R<000> - <255> G<000> - <255> B<000> - <255> W/A<000> - <255> S<000> - S<100>	Set intensity of each colour separately for color mixing and strobe rate
Auto Pr	<Pr01> - <Pr07> <Sp000> - <Sp100> <Dim000> - <Dim255>	Select built-in automatic programs, auto run speed and dimmer level
Mas/Sla	<M> <S>	Select Master/Slave modes
Reset	<N> <Y>	Recover manufactory default

DMX Address

After select the "DMX Add" and press "Enter", use "Up" and "Down" button to select the desired DMX address, press "Enter" to save new setting

DMX Mode

After select the "DMX Cha" and press "Enter", use "Up" and "Down" button to select the desired DMX mode, press "Enter" to save new setting

Dimmer Curve

After select the "Dimmer" and press "Enter", use "Up" and "Down" button to select the desired dimmer curves

Sound Active Mode

Entered "sound" mode, use "Up" and "Down" button to select the sensitivity Sen000-Sen100, press "Enter" to save new setting

Static Colour Mode

Entered "Static C" mode, you can select the desired solid color via the "UP" or "DOWN" buttons, press "Enter" to save new setting

8W RGBW LED		8W RGBA LED	
Value:	Function:	Value:	Function:
R	Red	R	Red
G	Green	G	Green
B	Blue	B	Blue
W	White	A	Amber
GB	Green + Blue	GB	Green + Blue
RB	Red + Blue	RB	Red + Blue
RG	Red + Green	RG	Red + Green
RGB	Red + Green + Blue	RGB	Red + Green + Blue
RW	Red + White	RA	Red + Amber
GW	Green + White	GA	Green + Amber
BW	Blue + White	BA	Blue + Amber
RGW	Red + Green + White	RGA	Red + Green + Amber
RBW	Red + Blue + White	RBA	Red + Blue + Amber
GBW	Green + Blue + White	GBA	Green + Blue + Amber
RGBW	Red + Green + Blue + White	RGBA	Red + Green + Blue + Amber

Manual Color Mode

Entered "Manual C" mode, use "Up" and "Down" button to select the each colour (RGBW or RGBA) intensity from 000 to 255, select strobe (S) speed from S000 to S100. (S000 is strobe off). Press "Enter" to save new setting.

Auto Run Mode

	Function
Pr 01	RGBW Model : R G B W colour switching RGBA Model : R G B A colour switching
Pr 02	15 colour switching
Pr 03	RGBW Model : R G B W colour fading RGBA Model : R G B A colour fading
Pr 04	15 colour fading
Pr 05	Color Macros Fading
Pr 06	Sound active mode
Pr 07	Multi fixture chases

Set auto run Pr 01 - Pr 05

Entered "Auto Pro" mode, use "Up" and "Down" button to select the built-in programs. Press "Enter" and use "Up" and "Down" button to select auto run speed from <Sp000> to <Sp100>. Press "Enter" and use "Up" and "Down" button to select dimmer of "Auto Pro" from <dim000> – <dim255>. Press "Enter" to save new setting.

Set sound active mode Pr 06

Entered "Auto Pro" mode, use "Up" and "Down" button to select the built-in program "Pr 06", press "Enter" and use "Up" and "Down" button to select the sound sensitivity level from <Sen000> to <Sen100>, press "Enter" to save new setting.

Set multi fixture chases Pr 07

Before starting, go to each fixture and reset the menu to fixture defaults.

1. On the master unit, setup the DMX address to the total number of fixtures in the string. For example, you may have a total of 20 par cans including the master, so the DMX address should be set to "20".
2. On the master unit, go to master/slave menu setting and set the unit to master
3. On the master unit, set the unit to "Auto Mode" "Pr 07" which supports multi fixture chases.
4. On each slave unit, setup the DMX address to the fixture position in the string. For example, if this unit is the 2nd unit in the string including the master, then set the DMX address to 2. If this the last unit of 20, then the DMX address should be set to 20. It is possible to double up fixture positions as well as fixture 1.
5. On each slave, go to the master/slave menu setting and set it to slave.

Master/Slave Operation

Set the master fixture to one of the stand-alone operating modes: automatic, sound, static color or manual color modes.

Set the slaves, entered "Mas/Sla" mode, set to "S", press "Enter" to confirm.

DMX Chart

2 channels Mode

Channel	Value	Function
1	000-255	Warm white to cool white
2	000-255	dimmer 0% ~ 100%

3 channels Mode

Channel	Value	Function
1	000-255	Red: 0% ~ 100%
2	000-255	Green: 0% ~ 100%
3	000-255	Blue: 0% ~ 100%

4 channels Mode

Channel	Value	Function
1	000-255	Red: 0% ~ 100%
2	000-255	Green: 0% ~ 100%
3	000-255	Blue: 0% ~ 100%
4	000-255	RGBW Model : White: 0% ~ 100% RGBA Model : Amber: 0% ~ 100%

6 channels Mode

Channel	Value	Function
1	000-255	Red: 0% ~ 100%
2	000-255	Green: 0% ~ 100%
3	000-255	Blue: 0% ~ 100%
4	000-255	RGBW Model : White: 0% ~ 100% RGBA Model : Amber: 0% ~ 100%
5	000-255	Master Dimmer 0% ~ 100%
6	000-009	No function
	010-019	Sound Active
	020-255	Strobe : Slow ~ Fast (1~30Hz)

10 channels Mode

RGBW Channel	Value	Function
1	000-255	Red: 0% ~ 100%
2	000-255	Green: 0% ~ 100%
3	000-255	Blue: 0% ~ 100%
4	000-255	RGBW Model : White: 0% ~ 100% RGBA Model : Amber: 0% ~ 100%
5	000-255	Master Dimmer 0% ~ 100% for CH1, 2, 3, 4 & 8
6	000-009	Strobe OFF
	010-255	Strobe (slow-fast 1-30Hz)
7	000-019	No Function
	020-039	RED 100% / GREEN 0% ~ 100% / BLUE 0%
	040-059	RED 100% ~ 0% / GREEN 100% / BLUE 0%
	060-079	RED 0% / GREEN 100% / BLUE 0% ~ 100%
	080-099	RED 0% / GREEN 100% ~ 0% / BLUE 100%
	100-119	RED 0% ~ 100% / GREEN 0% / BLUE 100%
	120-139	RED 100% / GREEN 0% / BLUE 100% ~ 0%
	140-159	RED 100% / GREEN 0% ~ 100% / BLUE 0% ~ 100%
	160-179	RED 100%~ 0% / GREEN 100% ~ 0% / BLUE 100%
	180-200	RGBW Model : RED 100% / GREEN 100% / BLUE 100% /WHITE 100% RGBA Model : RED 100% / GREEN 100% / BLUE 100% /AMBER 100%
	201-204	Color Temperature 1
	205-209	Color Temperature 2
	210-214	Color Temperature 3
	215-219	Color Temperature 4
	220-224	Color Temperature 5
225-229	Color Temperature 6	
230-234	Color Temperature 7	
235-239	Color Temperature 8	

Warm
↓
Cool

	240-244	Color Temperature 9	
	245-249	Color Temperature 10	
	250-255	Color Temperature 11	
8	000-009	No Function	
	010-049	RGBW Model : R G B W colour switching RGBA Model : R G B A colour switching	
	050-090	15 colour switching	
	091-131	RGBW Model : R G B W colour fading RGBA Model : R G B A colour fading	
	132-172	15 colour fading	
	173-213	Color Macros Fading	
	214-255	Sound active mode	
9	000-255	Speed of auto programs (slow ~ fast) or sound sensitivity for CH8	
10	000-009	Use dimmer curve from setting of control board	
	010-057	16 bits Linear dimmer 1	
	058-106	16 bits Non-linear dimmer 2	
	107-155	16 bits Non-linear dimmer 3	
	156-204	16 bits Non-linear dimmer 4	
	205-255	8 bits Linear dimmer 5	

TECHNICAL SPECIFICATIONS

Model	PARRGBW5X8	PAR5X8A	PARRGBW12X8	PAR12X8A
Dimensions and Weight				
Overall size LxWxH (mm)	207x227x120		263x293x98	
Weight (kg)	1.9		3.2	
Power				
Power Supply	100~240V AC, 50/60 Hz			
Power Consumption (w)	40		98	
Power I/O	IEC input connector		IEC input/output connector	
Fuse	T 1 A, 250 V		T 2 A, 250 V	
LED	5pcs 8W RGBW	5pcs 8W RGBA	12pcs 8W RGBW	12pcs 8W RGBA
Operation Modes	DMX, auto run, sound active, master/slave, manual colour control, static colour control			
Beam Angle	22°/ optional 55°			
Refresh Rate	2940Hz			
DMX Channel mode	2, 3, 4, 6, 10			
DMX Connectors	3-pin XLR / optional 5-pin XLR			

WARRANTY

Please refer to your local dealer or please contact Event Lighting Pty Ltd

Website: www.event-lighting.com.au