

# HAVOCH600F [-WH]

HYBRID MOVING HEAD WITH FRAMING

EVENT  
LIGHTING

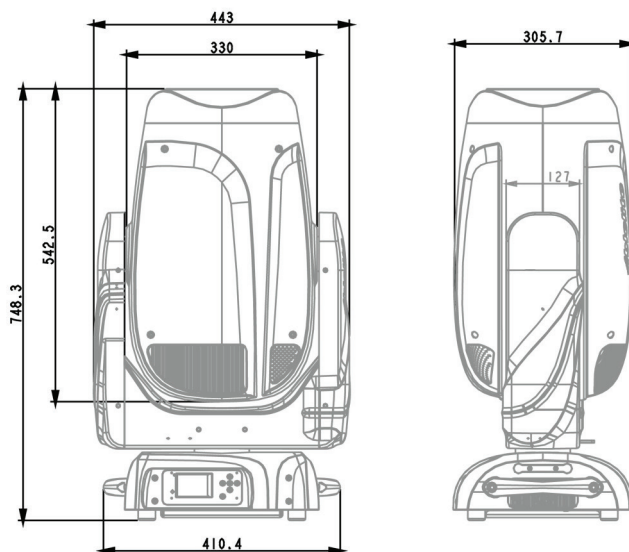

## Photometrics

Light Source:	600w LED White
Beam Angle:	4°-50°
Output:	20,050 lumen, 85,000 lux @ 2.5m at 5°
Led lifespan:	20.000 hours

## Colour

8 Colours + Open  
Linear CMY+CTO

## Gobos

Fixed:	8 + Open
Rotating:	7+ Open
Animation:	Yes

## Effects

Dimming:	0~100%
Strobe:	Yes
Focus:	Motorised
Prism:	Rotating 4 facets
Frost:	Yes
Zoom:	Yes (4° to 50°)

## Movement

	16 bit resolution
	Auto repositioning
Pan:	630° (4.4 sec) or 540°(3.9 sec)
Tilt:	233° (2.3 sec)

## Power

Power consumption:	590W Max.
Input Voltage:	100~240 V AC, 50/60 Hz
Connection:	Neutrik® PowerCON in/out

## Control

Control Protocol:	DMX512, RDM, Art-Net, optional CRMX
DMX Channels:	28/30/37/38
Interface:	5-pin XLR in/out, RJ45 in/out
RDM:	function to change DMX address
Display	2.4" colour LCD control panel
Software Upgrade	Yes, via DMX

## Housing

Materials:	ABS & Steel, matte black or white finish
Dimensions:	443x748x305mm
Cooling:	Multi sensor thermostat controlled variable speed fan
IP rating:	IP20
Net Weight:	31 kg
Rigging:	2x omega brackets with 1/4-turn quick locks

## Lux

	2.5m	5.0m	7.5m	10.0m
@ 6°	Ø0.27	Ø0.55	Ø0.81	Ø1.08
	85,700	21,720	9,630	5,503
@ 48°	Ø2.23	Ø4.45	Ø6.68	Ø8.90
	4,377	1,535	715	530



## Colour wheel



## Fixed gobo wheel

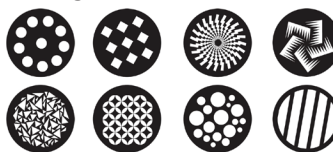

## Rotating gobo wheel

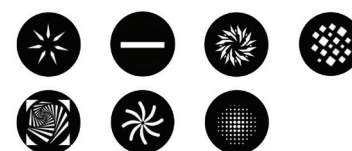

## Road Case (Optional)

**HAVOCH600FCASE1**  
Road case to suit 1 unit  
of HAVOCH600F  
(Horizontal loading)

