



Fresnel

Model No. F2X48

USER MANUAL



For safety, please read this user manual carefully before initial use.

Event Lighting reserves the right to revise the manual at any time. Information and specifications within this manual are subject to change without notice. Event Lighting assumes no liability or responsibility for any errors or omissions. Please consult Event Lighting for any clarification or information regarding this item.

www.event-lighting.com.au

Ver 3.0

CONTENTS

Safety Instructions

- Power input & power Linking

Product Installation

- Fuse replacement

Diagrams

- Lux chart
- Dimensions

Control Board Operation

- DMX address setting
- DMX modes setting
- Manual colour setting
- Master/slave setting

DMX chart

Technical specifications

Warranty

Safety Instructions

WARNING

- Do not open this device, there is no user-serviceable parts inside. Risk of electric shock.
- Do not look at the light source when the device is on.
- **CAUTION:** This unit's housing may be hot during and after operation.
- Install this device in a location with adequate ventilation, at least 20 inch (50 cm) from adjacent surfaces.
- Do not leave any flammable material within 50 cm of this unit while operating or connected to power.
- Use a safety chain when mounting this device overhead.
- Do not operate this device outdoors or in any location where dust, excessive heat, water, or humidity may affect it.
- Do not operate this device if the housing, lenses, or cables appear damaged.
- Do not connect this device to a dimmer or rheostat.
- ONLY connect this device to a grounded and protected circuit.
- ONLY use the hanging bracket to carry this device.
- In case of a serious operating problem, stop using immediately.
- The maximum ambient temperature is 104° F (40° C). Do not operate this device at higher temperatures.

Power Input & Power Linking

This device has an auto-switching power supply work with input voltage range of 100~240 VAC, 50/60 Hz.

Link up to the maximum 15A. DO NOT exceed this number.

Product Installation

This device can be mounted in many orientations provided each individual device is secured by the use of correct mounting bracket.

Use a safety chain when mounting this device overhead.

Fuse Replacement

If the fine-wire fuse of the device fuses, only replace the fuse by a fuse of same type and rating.

Before replacing the fuse, unplug mains lead.

Procedure:

Step 1: Unscrew the fuse holder on the rear panel with a fitting screwdriver from the housing (anticlockwise).

Step 2: Remove the old fuse from the fuse holder.

Step 3: Install the new fuse in the fuse holder.

Step 4: Replace the fuse holder in the housing and fix it.

Lux Chart

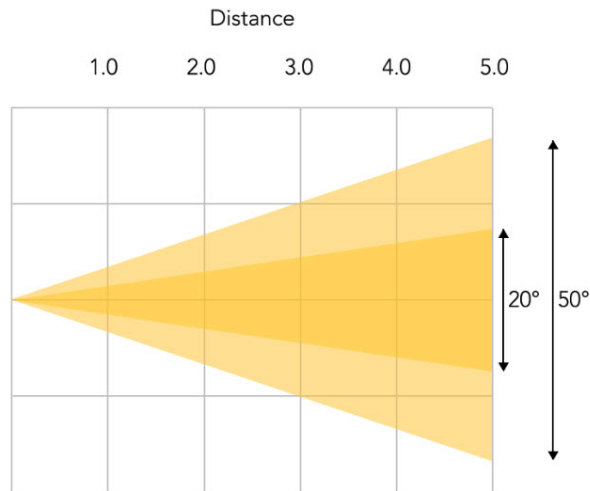

LUX @ 20°	Ø 0.35	Ø 0.71	Ø 1.06	Ø 1.41	Ø 1.76
2700 K	5,100	1,200	546	298	198
5700 K	6,850	1,680	745	422	273
Full	11,600	2,780	1,230	685	445

LUX @ 55°	Ø 0.93	Ø 1.87	Ø 2.8	Ø 3.73	Ø 4.66
2700 K	1,550	393	172	106	75
5700 K	2,150	530	245	148	104
Full	3,600	895	395	245	175

Dimensions

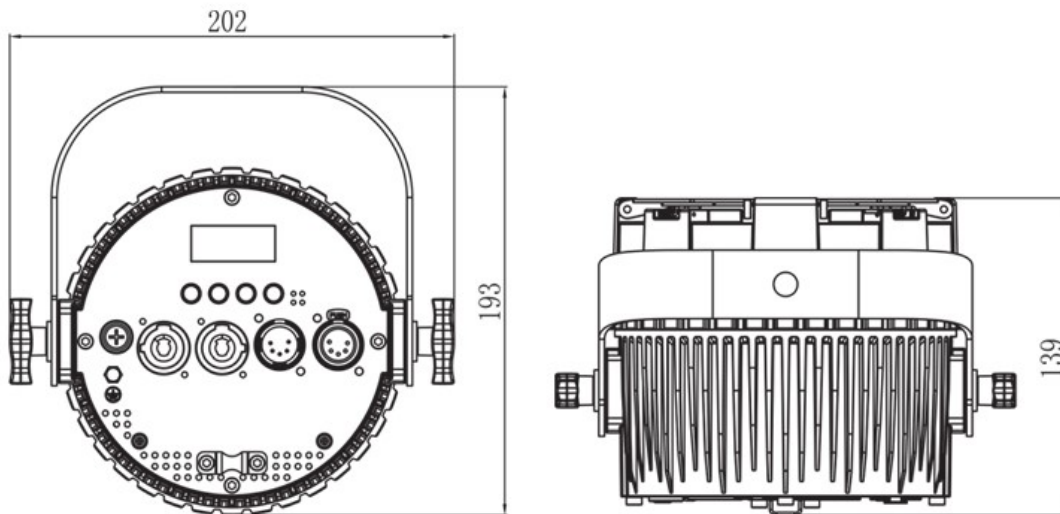

CONTROL BOARD OPERATION

Display	Options / Values	Function
DMX Add	<001> - <508>	To set DMX address
DMX Cha	<01>, <02>, <05>	To set DMX channel modes
Manual	Preset <StraW> <WarmW> <White> <CoolW> <Steel>	To select colour from 5 preset colour temperature modes
	Finetune <Straw> <Straw+> <Stra++> <- -Warm> <-WarmW> <WarmW> <WarmW+> <Warm++> <- -Whit><-White> <White> <White+> <Whit++> <- -Cool> <-CoolW> <CoolW> <CoolW+> <Cool++> <- -Stee> <-Steel> <Steel>	To select colour from 21 fine tune colour temperature modes
	Dimmer <000> - <100>	To set dimming intensity
Mas/Sla	< Sla> / <Mas>	To set Master/Slave modes
Reset	<N> / <Y>	To reset factory default setting
Update	<N>/ <Y>	Select to update firmware
	<START>	Use this fixture to update another fixture's software

DMX Addressing:

After selecting the "DMX Add" press "Enter", use "Up" and "Down" buttons to select the desired DMX address, press "Enter" to save new setting

DMX Modes

After selecting the "DMX Cha" press "Enter", use "Up" and "Down" buttons to select the desired DMX mode, press "Enter" to save new setting

Manual

After entering "Manual" mode, use "Up" and "Down" buttons to select the colour from preset colour group and fine tune group, set intensity from 000 to 255, press "Enter" to save new setting

Master/Slave

Set the master fixture to one of the standalone operating modes.

Set the slave, enter "Mas/Sla" mode, set to "Slave", press "Enter" to save the setting.

Firmware update

Use fixture A to update fixture B's firmware

- Set fixture A to "Update" mode, select "Y" then select "START"
- Link fixture A and fixture B with DMX cable, then power up fixture B
- Press "Enter" on fixture A, fixture B's firmware will be copied from fixture A.

*Ensure that fixture A and B are of the same type, otherwise damage may occur.

* Only fixture A and B should be in the DMX chain when updating firmware.

Fade Mode

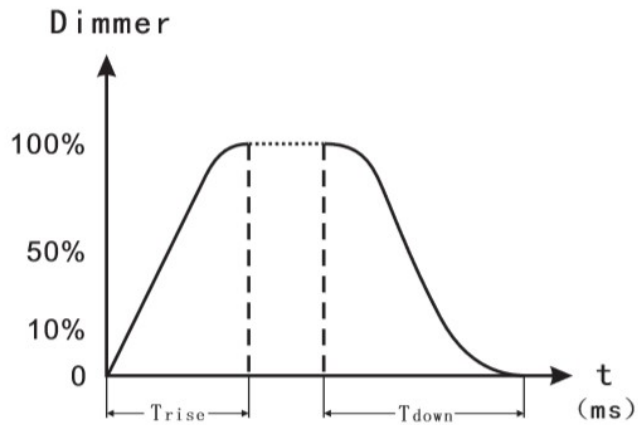

DMX mode \ DMX delay	Trise (ms)	Tdown (ms)
Standard	0	0
Stage	300	600
TV	500	800
Architec	600	1000
Theatre	620	1500

DMX Chart

1 channels Mode

Channel	Value	Function
1	000 - 255	Dimmer & Colour temperature

2 channels Mode

Channel	Value	Function
1	000 - 255	Dimmer 0% ~ 100%
2	000 - 255	Warm white to cool white

5 channels Mode

Channel	Value	Function
1	000 - 255	Master dimmer coarse: 0% ~ 100%
2	000 - 255	Master dimmer fine: 0% ~ 100%
3	000 - 255	Warm white to cool white
4	000 - 007	Shutter closed (No light)
	008 - 015	Shutter on
	016 - 119	Strobe slow to fast (1-25Hz)
	120 - 127	Shutter on
	128 - 183	Strobe random slow to fast
	184 - 191	Shutter on
	192 - 247	Strobe audio sensitivity low to high
	248 - 255	Shutter on
5	000 - 050	Standard
	051 - 101	Stage
	102 - 152	TV
	153 - 203	Architect
	204- 255	Theater

TECHNICAL SPECIFICATIONS

Power

Power Supply: 100~240V AC, 50/60 Hz

Power Consumption: 75W

Power Connection: Neutrik® PowerCON in / out

Photometrics

Light Source: 1 x 48W*2 cool white 5700K and warm white 2700K COB LED

CRI: 95

Beam Angle: 20° - 50°

Field Angle: 50° - 67°

Output: 1230 lux @3M at 20°, 395 lux @3M at 50°

Lens: 80mm Fresnel

PWM: 1,200Hz

LED Lifespan: 50,000 hours

Effects

Dimming: 16-bit 0 - 100%

Strobe: 1 – 25 Hz

Zoom: Manual Zoom 20° to 50°

Barn Door: Included

Gel Clip: Included

Control

Operational Modes: Manual, Master / Slave & DMX

Display: 4-button LCD control panel

DMX Protocol: DMX512

DMX Channel Mode: 1 / 2 / 5

DMX Interface: 3-pin XLR (Optional 5-pin XLR)

Housing

Housing Materials: Die- cast Aluminum Housing

Housing Finishing: Matte Black

Cooling: Fanless Cooling with Temperature Protection

Net Weight: 2.3 kg

Dimension: 202 X 139 X 193mm

WARRANTY

Please refer to your local dealer or please contact Event Lighting Pty Ltd

Website: www.event-lighting.com.au.