

CONTENTS

1. Safety information	1
2. Introduction	4
2.1. Package & Transportation	4
2.2. Dimensions	4
2.3. Structure	4
2.4. Accessories	5
3. Technical Specification	6
3.1. Specifications	6
3.2. Photometrics	7
4. Operation	8
5. DMX 512 Channels	9
6.. Connecting power and data	14
6.1. Connecting power	14
6.2. Connecting data	15
7. Fixture Installation	16
7.1. Installation Tips	17
7.2. Installation Steps	17
8. Troubleshooting	21
9. Fixture cleaning	21

1. Safety information



Please read the instruction carefully which includes important information about the installation, usage and maintenance.

WARNING

Please keep this User Manual for future consultation. If you sell the unit to others, be sure that they also know well instruction manual.

Important:

Damages caused by the disregard of this user manual are not subject to warranty. The dealer will not accept liability for any resulting defects or problems.

- *Unpack and check carefully to ensure that there is no transportation damage before using the device; please do not use if any damage, and contact the local dealer or manufacturer immediately.
- *Do not connect the device to any dimmer pack .
- *Do install and operate by qualified operator.
- *It's important to ground the yellow/green conductor to earth in order to avoid electric shock.
- *Disconnect the power before servicing and cleaning, or not using for a long time.
- *Do not allow children to operate the fixture.
- *Use safety cable when fixing the unit, handle the fixture by carrying the base.
- *Always ensure that the device is firmly fixed to avoid vibration and slipping off during operation.
- *The device must be installed in a location with adequate ventilation, at least 50 cm from adjacent surfaces, be sure that no ventilation slot is blocked, otherwise the device will be overheated.
- *Before operation, ensure that you connect the device to proper voltage in accordance with the specification in manual or on product's specification label.
- *Minimum ambient temperature TA: -15°C; Maximum ambient temperature TA: 45°C, do not operate device at a lower or higher temperature. To avoid electric shock, ensure disconnect the power source while replacing any of accessories.
- *Keep flammable materials away from the fixture while operating to avoid fire hazard.

- *Make sure the power cable is not crimped or damaged, replace it immediately if damaged.
- *Fixture's surface temperature might reach up to 65°C, do not touch the housing bare-handed during operation.
- *Avoid any flammable liquids, water or metal from entering the unit. Once it has, cut off the mains power immediately.
- *Do not operate in a dirty or dusty environment. Clean the fixture regularly.
- *Do not touch any wire during operation as there might be a hazard of electric shock.
- *Avoid entanglement of the power cable with other wires.
- *The minimum distance to objects must be more than 5 meters.
- *Avoid direct eye exposure to the light source while the fixture is working.
- *The housing or lenses must be replaced if they are visibly damaged, only original parts can be allowed.
- *Do not attempt to operate the fixture if it becomes damaged. Do not attempt any repairs personally. Repairs carried out by unskilled people can lead to damage or malfunction. Please contact the nearest authorized technical assistance center if needed.
- *Use original package if device is to be transported; and confirm PAN/TILT locks are released before packing.
- *Do not expose the fixture front lens to light beams from direct sunlight or other strong light sources while unpacking, installation, using and extended idle times outdoor, or the device will be caused severe internal damage.

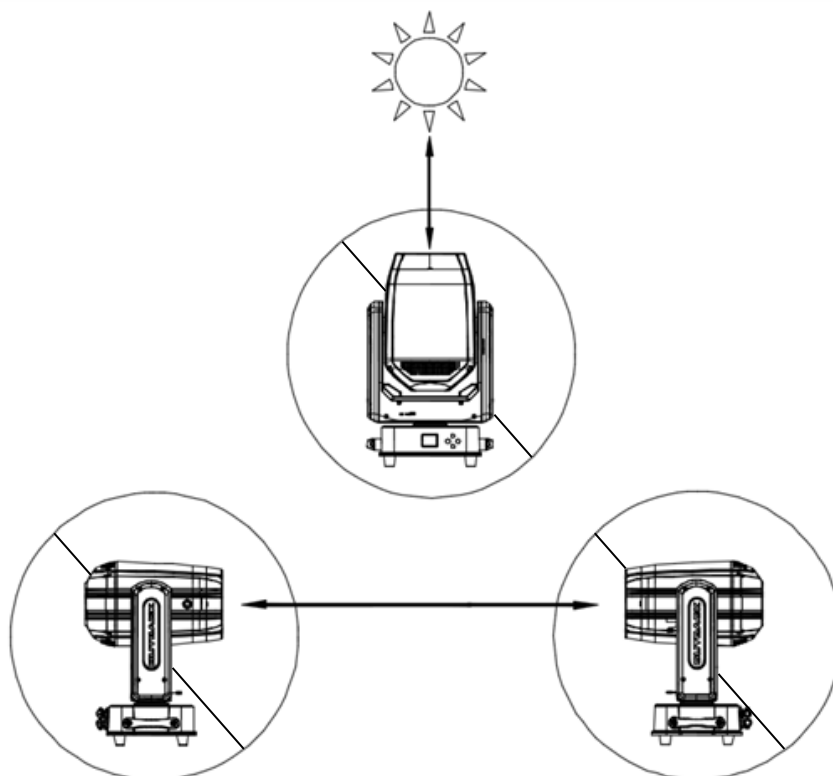

2. Introduction

2.1. Package & Transportation :

Do not pack the device into carton or flight case before cooling completely, only 2 flight cases can be allowed to stack.

2.2. Dimensions (mm)

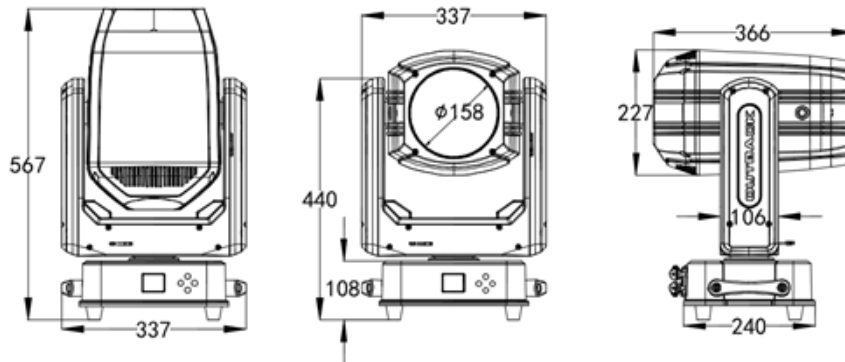

2.3. Overview:

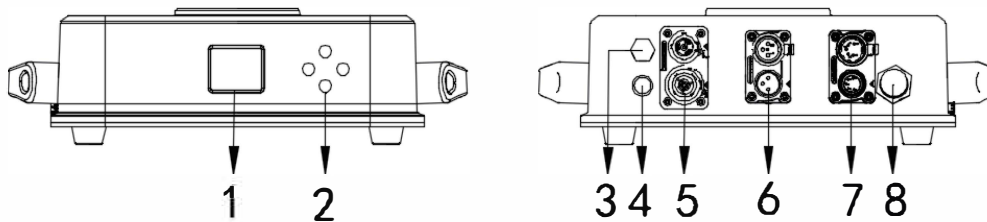

1.Display	Show menus and functions	
2.Buttons	MENU	To move backward or leave the menu
	^ UP	To go backward to move up
	v DOWN	To go forward to move down
	ENTER	To confirm the selected function
3.Release Valve		
4.Fuse		
5.Power IN/OUT	To connect to supply power and next fixture	
6.DMX IN/OUT	3-PIN XLR (Firmware optional)	
7.DMX IN/OUT	5-PIN XLR (Firmware optional)	
8.Waterproof wireless antenna		

2.4. Accessories:

Item	Qty	
Omega bracket	2	PCS
Safety cable	1	PCS
Signal cable	1	PCS
Power cable	1	PCS

3. Technical Specification

3.1. Specification

AC POWER/ Frequency	100-264V AC; 50/60Hz	
Power Consumption	230VAC/522W;110V AC/281W	
Light Source	180W LED	
Color Temperature	9000K	
Beam angle	1.8°	
Color system	Color wheel-1	14 + open
	Color wheel-2	8 + open
Gobo wheels	Mixed gobo wheel	10 fixed + 4 rotated + open (exchangeable)
Movement	PAN	540°
	TILT	270°
	Automatic PAN/TILT repositioning	
	16-bit precision scanning	
	Mechanical PAN/TILT lock for safe transportation and maintenance	
Construction	Display	TFT screen
	DMX IN/OUT	3-PIN/5-PIN XLR(Firmware optional)
	Power IN/OUT	Waterproof power connector in/out
	Protection rating	IP65
Control and programming	DMX channels	22CH
	Protocols	DMX 512, RDM, W-DMX.(Art-Net, sACN, optional)
	Firmware update	Via DMX
Dynamic effects	0-100% continuous dimming and strobe effects	
	Two indexing/rotating prisms (4-facet circular prism + 4-facet linear prism, overlap)	
	Independent frost effect	
	linear prism, overlap)	
	Independent frost effect	

Dimensions	Motorized focus system
	337*240*567 mm
Weight	17.5 kgs

3.2. Photometrics:

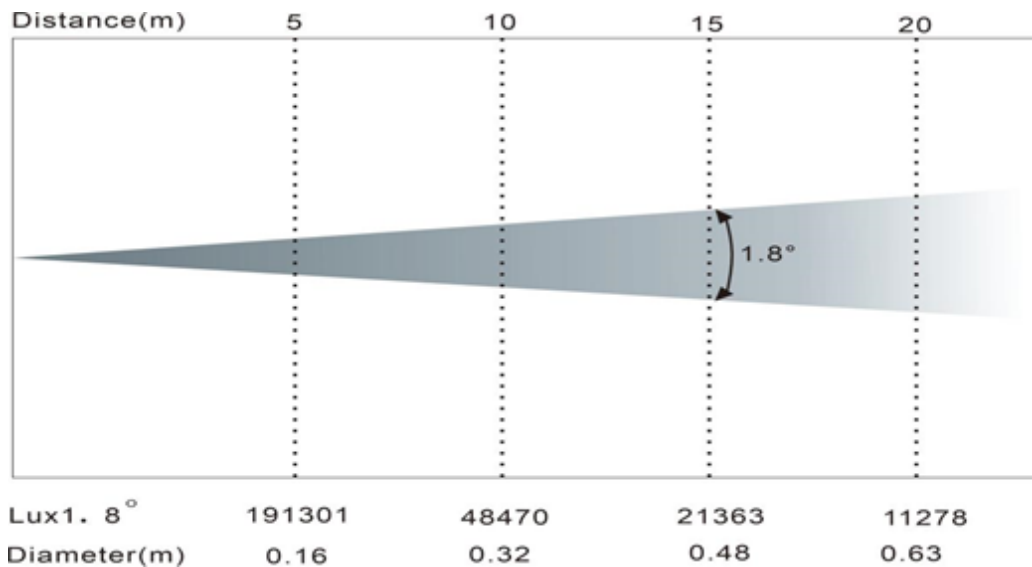

4. Operation

*Press [MENU] button to control menus.

*Press [^UP] and [vDOWN] button to navigate the menu structure.

*To select menu option or confirm the selection, press [ENTER]

*Return to upper level or without any change, press [MENU] button

*With battery inside, press one of buttons for 5 seconds to operate the menu if disconnect the power.

Note: The screen will be automatically locked if without any operation for a long time, and press [MENU] button in 5 seconds to unlock the screen. Main functions as below:

Address	001-512			
Run Mode	DMX	22CH		
	AUTO	Master	Master/Alone	
		Run Mode	Continuous/ Step	
		Run Speed	0-255	
	Manual	Pan Tilt		
Setting	Pan Reverse	On/Off		
	Tilt Reverse	On/Off		
	Screen Reverse	Up/Down/Auto		
	Auto Reposition	On/Off		
	Pan Angle	540/360/180		
	Tilt Angle	Full/180/90		
	Limit Mode	Off/Up/Down		
	Password	On/Off		
	DMX Loss	Hold/ Black		
	Fan Mode	Auto/Full/ECO		
	DMX Backlight	On/Off		
	Dimmer Curve	Line/ Square Law/ Inv Square/ S-Curve		
	Dimmer Freq	600/1200/1800/3600/7200/25K		
	WDMX setting	WDMX Off/WDMX On/WDMX Reset		
	Calibrate	Password		

		Pan	
	Factory Set	On/Off	
Reset	Reset All		
	Reset Scan		
	Reset Other		
System Info	Temperature		
	Error List		
	SoftwareVersion		
	System Update	On/Off	
	Sys Info		
Program	Select Prog	Program 1 ~10	
	Program Edit	AutoProgram1	Test Step1=Scene
		AutoProgram10	Step8=Scene
Scene Edit	Scene Edit: 001-128	Pan...Pan=.. SceneTime=..	

5. DMX Protocol

Channel	Value	Function
22CH		
1	0-255	Pan 0°-540°
2	0-255	Pan fine
3	0-255	Tilt 0°-270°
4	0-255	Tilt fine
5	0-255	Pan/Tilt Speed-Fast to slow X/Y
6		Shutter
	0-3	Off
	4-7	On
	8-76	Synchronized strobe slow to fast
	77-145	Pulse strobe slow to fast
	146-215	Random strobe slow to fast
	216-255	On
7	0-255	Dimmer 0% - 100%
8	0-255	Dimmer fine
9		Colour wheel -1
	0-3	Open
	4-7	Colour 1
	8-11	Colour 2

	12-15	Colour 3
	16-19	Colour 4
	20-23	Colour 5
	24-27	Colour 6
	28-31	Colour 7
	32-35	Colour 8
	36-39	Colour 9
	40-43	Colour 10
	44-47	Colour 11
	48-51	Colour 12
	52-55	Colour 13
	56-59	Colour 14
	60-219	Split Colours
	220-235	Colour wheel continuous rotation CCW fast to slow
	236-239	Stop
	240-255	Colour wheel continuous rotation CW slow to fast
10		Colour wheel - 2
	0-3	Open
	4-7	Colour 1
	8-11	Colour 2
	12-15	Colour 3
	16-19	Colour 4

	20-23	Colour 5
	24-27	Colour 6
	28-31	Colour 7
	32-35	Colour 8
	36-219	Split Colours
	220-235	Color wheel continuous rotation CCW fast to slow
	236-239	Stop
	240-255	Color wheel continuous rotation CW slow to fast
11		Gobo wheel
	0-1	Open
	2-3	Gobo 1
	4-5	Gobo 2 - Rotated
	6-7	Gobo 3
	8-9	Gobo 4
	10-11	Gobo 5
	12-13	Gobo 6 - Rotated
	14-15	Gobo 7
	16-17	Gobo 8
	18-19	Gobo 9
	20-21	Gobo 10 - Rotated
	22-23	Gobo 11
	24-25	Gobo 12

26-27	Gobo 13
28-29	Gobo 14 - Rotated
30-36	Gobo 1 - Shaking
37-43	Gobo 2 - Shaking
44-50	Gobo 3 - Shaking
51-57	Gobo 4 - Shaking
58-64	Gobo 5 - Shaking
65-71	Gobo 6 - Shaking
72-78	Gobo 7 - Shaking
79-85	Gobo 8 - Shaking
86-92	Gobo 9 - Shaking
93-99	Gobo 10 - Shaking
100-106	Gobo 11 - Shaking
107-113	Gobo 12 - Shaking
114-120	Gobo 13 - Shaking
121-127	Gobo 14 - Shaking
128-187	Gobo wheel continuous rotation CCW fast to slow
188-195	Stop
196-255	Gobo wheel continuous rotation CW slow to fast
12	Gobo Rotation
	0-127

	128-187	Gobo continuous rotation CCW fast to slow
	188-195	Stop
	196-255	Gobo continuous rotation CW slow to fast
13	0-255	Focus 0%-100%
14	0-255	Focus fine
		Prism 1 – 24-facet circular
15	0-127	Off
	128-255	On
		Prism 1 Rotation
	0-127	Prism 1 Index
16	128-187	Prism 1 continuous rotation CCW fast to slow
	188-195	Stop
	196-255	Prism 1 continuous rotation CW slow to fast
		Prism 2 – 5-facet linear
17	0-127	Off
	128-255	On
		Prism 2 Rotation
	0-127	Prism 2 Index
18	128-187	Prism 2 continuous rotation CCW fast to slow
	188-195	Stop
	196-255	Prism 2 continuous rotation CW slow to fast
19		Function

	0-31	No function
	32-63	Reset Pan and Tilt Motor (hold 5s)
	64-95	Reset Other Motor (hold 5s)
	96-127	Reset All Motor (hold 5s)
	128-137	Built-in program 1
	138-147	Built-in program 2
	148-157	Built-in program 3
	158-167	Built-in program 4
	168-177	Built-in program 5
	178-187	Built-in program 6
	188-197	Built-in program 7
	198-207	Built-in program 8
	208-217	Built-in program 9
	218-227	Built-in program 10
	228-255	No function
20		Frost
	0-127	Off
	128-255	On
21		Movement Macro
	0-5	No function
	6-30	Movement Macro 1
	31-55	Movement Macro 2

	56-80	Movement Macro 3
	81-105	Movement Macro 4
	106-130	Movement Macro 5
	131-155	Movement Macro 6
	156-180	Movement Macro 7
	181-205	Movement Macro 8
	206-230	Movement Macro 9
	231-255	Movement Macro 10
22	0-255	Move Speed-Fast to slow

6. Connecting Power & Data

6.1 Connecting Power

- Release PAN/TILT locks before connecting power.
- The fixture can be operated on 100-260Vac, 50/60 Hz AC main power.
- The maximum power consumption is 2 1W.

The fixture must be grounded/earthed and able to be isolated from AC power. The AC power supply must incorporate a fuse or circuit breaker for fault protection. All wiring and connecting works must be handled by qualified electrician.

Power cables color code as below:

Cable	Color (US)	Cable	Color (EU)	Symbol	Conductor
	Black		Brown	L	Live
	White		Blue	N	Neutral
	Green		Yello/Green	 Or 	Ground(earth)

6.2 Connecting Data

The fixture is equipped with 3-PIN / 5-PIN XLR sockets for DMX IN/OUT. Normally 150 meters is workable for signal cable, and signal amplifier will be necessary if longer than this distance. Use a IP-rated XLR to connect the controller with the fixture or one fixture with another.

Building a serial DMX chain:

Connect the DMX data output from the controller to the fixture’s data input socket. Connect the DMX output of the first fixture in the DMX chain with the DMX input of the next fixture. Always connect one output with the input of the next fixture until all fixtures are connected. Up to 32 fixtures can be connected to the same DMX link. Terminate the DMX out cable of the last fixture in the data link with a 120Ω DMX terminator.

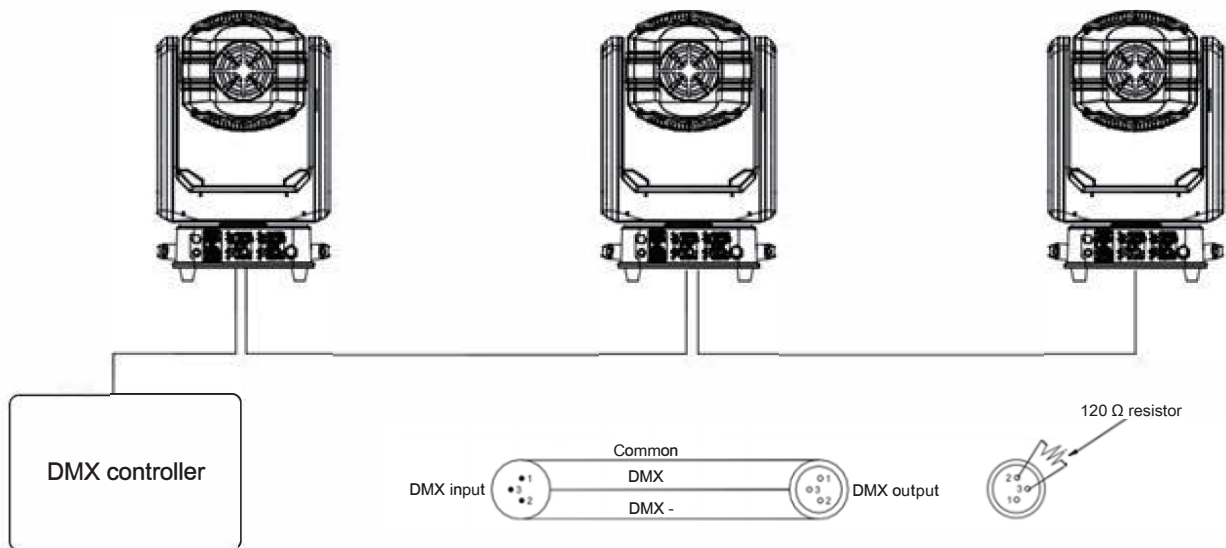

7. Installation

7.1. Instruction

The fixture with IP65-rated which designed for both indoor and outdoor events, also protected from :

- Dust, cannot enter into the device in sufficient quantities to interfere its operation.
- Water jets from any direction.

Install and operate by qualified operator, most important to install in the outside areas of walkway, seating, or away from the areas that unauthorized personnel can reach to the fixture by hand; Never stand directly under the fixture while installation, removing or servicing.

7.2 Installation

1). Do confirm the clamps and safety cable are intact before installation.

Ensure that the truss or objects of installation must be able to hold 6 times the weight of the fixture without any deformation. Extra safety cable is necessary that can hold at least 10 times the weight of the fixture whenever installing, to ensure the fixture will not fall if the clamp fails. (Do not install safety cable on the bracket)

2). The fixture is fully operational in three different mounting positions: hanging upside-down, mounted sideways on trussing, or standing on the floor.

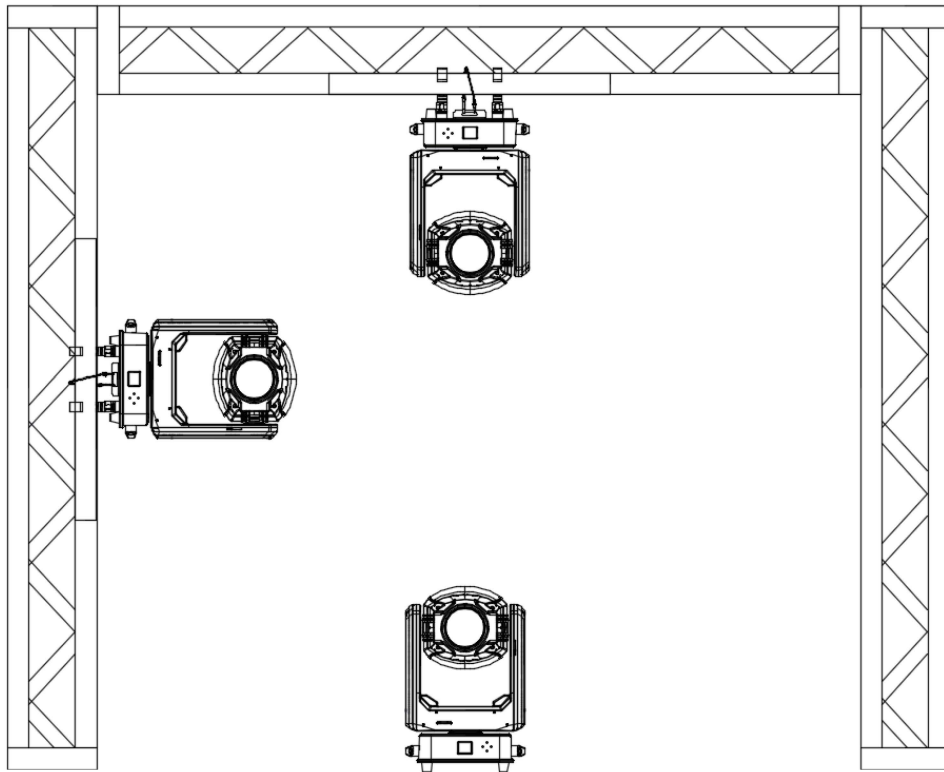

Side Mounting

To maintain the IP65 rating integrity of the fixture, all cables must be towards the ground to prevent water accumulation around connectors.

TFT display

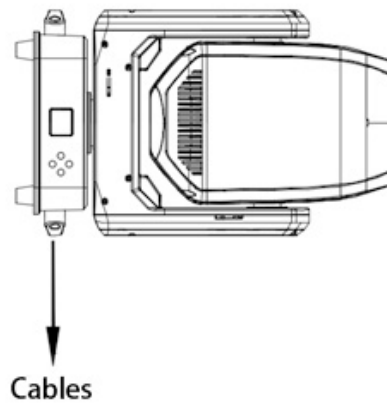
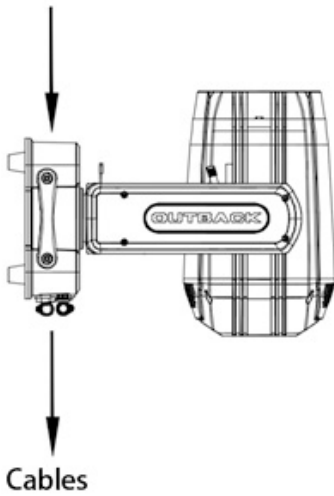

3). Installing steps



Safety cable attachment point

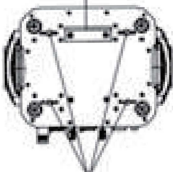

Omega bracket attachment point

Clamp
Omega bracket

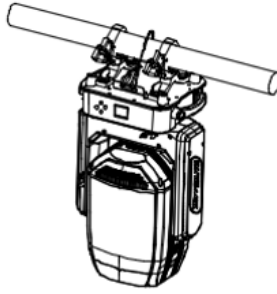
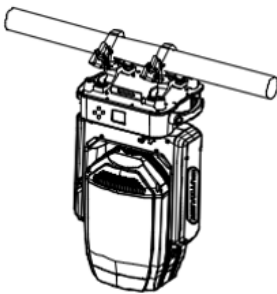
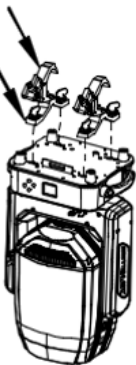

4). Color wheels

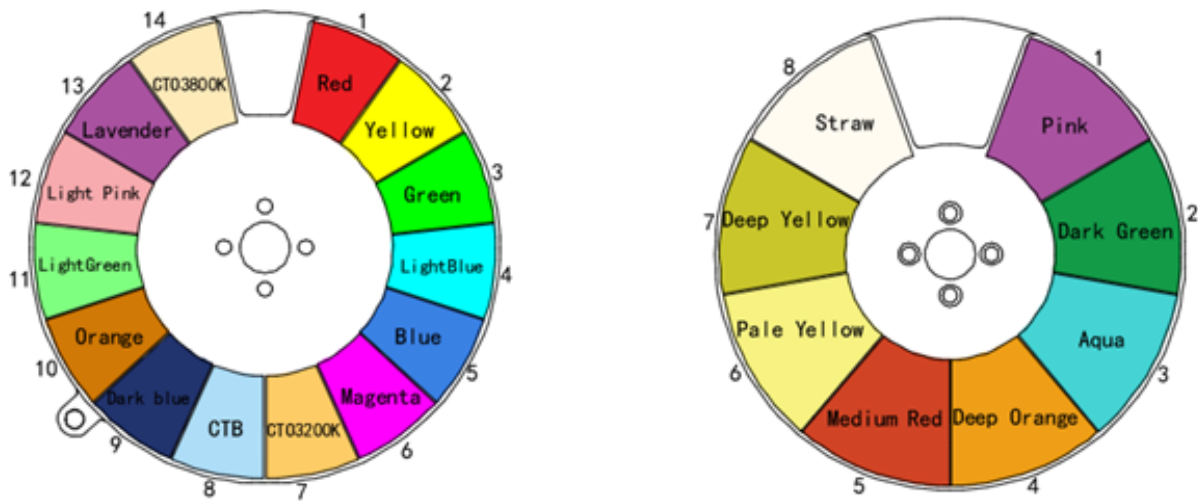

5). Gobo wheels

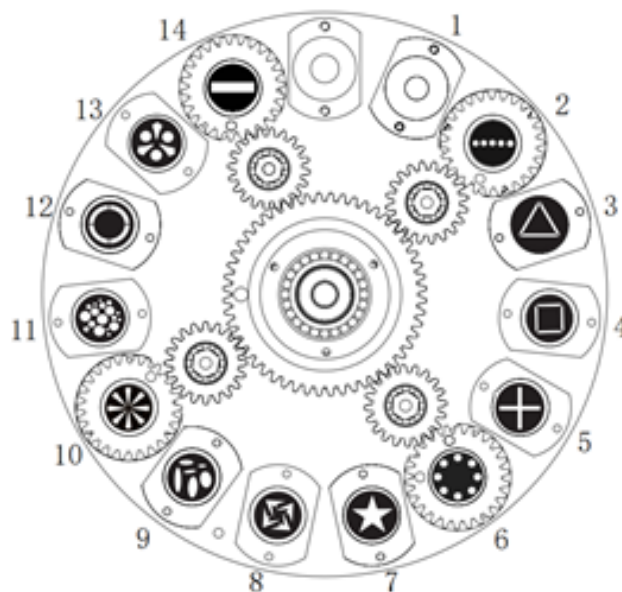

Pay attention to exchange gobo as below:

*There is a special coating on original gobo for heat resisting, and high temperature resistance material or high quality glass is asked for customized gobo.

*Customized gobo dimension, structure and material must same as original, it will be damaged if different and out of the range of warranty.

*Do not use the gobo with black coating on both sides, it will be nondurable as to absorb abundant heats.

No	Gobo wheel	Gobo Diameter	Image Area Diameter	Gobo Thickness
1	Mixed gobo wheel	12mm	5mm	0.5mm

8. Trouble Shooting

Error warning are mentioned in display when fixture fail and will disappear when it is repaired

Problem	Potential cause(s)	Remedies
Fixture not respond when power on	No power	Power on
	Fuse damaged	Replace fuse
	No power output from PSU	Inspect PSU
	Internal circuit in poor contact	Reconnect
Fixture out of control	DMX cable is disconnected	Inspect DMX cable
	Incorrect DMX address or DMX mode	Inspect and enter into correct DMX address or DMX mode
Light output cuts off suddenly	Fixture is too hot	Power off and cool fixture; clean fixture;
PAN/TILE reset error	Inspect the position of magnet if fall off or damage	Adjust/Replace
	Whether there are obstacles around operating range	Inspect
	Weather if hall element on PAN/TILT is damaged	Inspect/Replace
	Whether the wire connecting the hall element on PAN/TILT and the PCB board are in poor contact or disconnected	Reconnect
	Whether motor is damaged	Inspect/Replace
	Whether the related circuit of motor drive PCB is damaged	Inspect/Replace
	Whether the encoder is damaged	Inspect/Replace
	Whether the wire connecting the encoder and PCB board are in poor contact or disconnected	Reconnect
Cyan/Magenta/Yellow /CTO reset error	Inspect the position of magnet if fall off or damage	Inspect/Replace
	Whether obstacles around operating range	Inspect
	Weather the hall element on color wheel is damaged	Inspect/Replace
	Whether the wire connecting the hall element on color wheel and PCB board in poor contact or disconnected	Reconnect
	Whether the related circuit of color wheel motor and drive PCB is damaged	Replace

Rotating Gobo wheel reset error	Inspect the position of magnet if fall off or damage	Inspect/Replace
	Whether obstacles around operating range	Inspect
	Whether the hall element on gobo wheel is damaged	Adjust/Replace
	Whether the wire connecting the hall element on color wheel and PCB board in poor contact or disconnected	Reconnect
	Whether the related circuit of gobo wheel motor and drive PCB is damaged	Replace
Prism reset error	Inspect the position of magnet if fall off or damage	Adjust/Replace
	Whether obstacles around operating range	Inspect
	Whether the hall element on prism is damaged	Adjust/Replace
	Whether the wire connecting the hall element on prism and PCB board in poor contact or disconnected	Reconnect
	Whether the related circuit of prism motor and drive PCB is damaged	Replace
Focus/Zoom reset error	Inspect the position of magnet if fall off or damage	Adjust/Replace
	Whether obstacles around operating range	Inspect
	Whether the hall element on focus or zoom is damaged	Adjust/Replace
	Whether the wire connecting the hall element and PCB board in poor contact or disconnected	Reconnect

	Whether the related circuit of motor and drive PCB is damaged	Replace
Impure color	Light output to be feeble	Replace
	Dust or spot on color filter	Clean
	Color filter fall off or damage	Replace
Dim image	Dust or spot on optical lens	Clean
	Optical lens damaged	Replace
Noted! All these Potential causes for reference only, do not disassemble or maintenance by unqualified personnel		

9. Fixture cleaning

Warning!

Do disconnect the power before open the housing.

Regular cleaning is very important for fixture life and performance. Buildup of dust, dirty, smoke particles, fog fluid residues etc. degrades the fixture’s light output and cooling ability. Cleaning schedules for lighting fixtures vary greatly depending on the operating environment. Environmental factors that may result in a need for frequent cleaning

included:

- *Using smoke or fog machines.
 - *High airflow rates (such as near air conditioning vents)
 - *Airborne dust (from stage effects, building structures and fittings or the natural environment at outdoor events, for example).
- If one or several factors is present, please inspect fixtures and see whether cleaning is necessary before operating. Follow these precautions when cleaning the fixture:
- *Operate in a clean, dry and well-lit area.
 - *Use gentle pressure only while cleaning optical components, with water and a mild detergent is better, do not use alcohol, solvents or abrasives things. Optical components are fragile and easily scratched, be careful while cleaning.